

4

3

2

1

Parts List			
ITEM	QTY	PART NUMBER	DESCRIPTION
1	2	0500BBS	Black Buffer Seal 1.0 OD x .5 ID x .10 Neoprene
2	2	24107	Button Head, Hex, 1/2-13 UNC x 0.75
3	1	57XL-40	40 Micron FILL w/30 Mesh Stainless Strainer
4	1	APP1250	1 1/4" NPT SQUARE SOCKET PLUG
5	1	N_A4535-ST	NAM WELDMENT ~24.21 lbs
6	1	T-LLG-5	SIGHT/TEMP. GAUGE, 5"

AMP PARTS INCLUDE:

-AMK-624-C MOUNTING KIT (STD) OR -S (UPGRADE)

NOTE:

-PLUG ALL PORTS FOR SHIPMENT

S/N BETWEEN FILL & SEAM

HYDRAULIC OIL ONLY

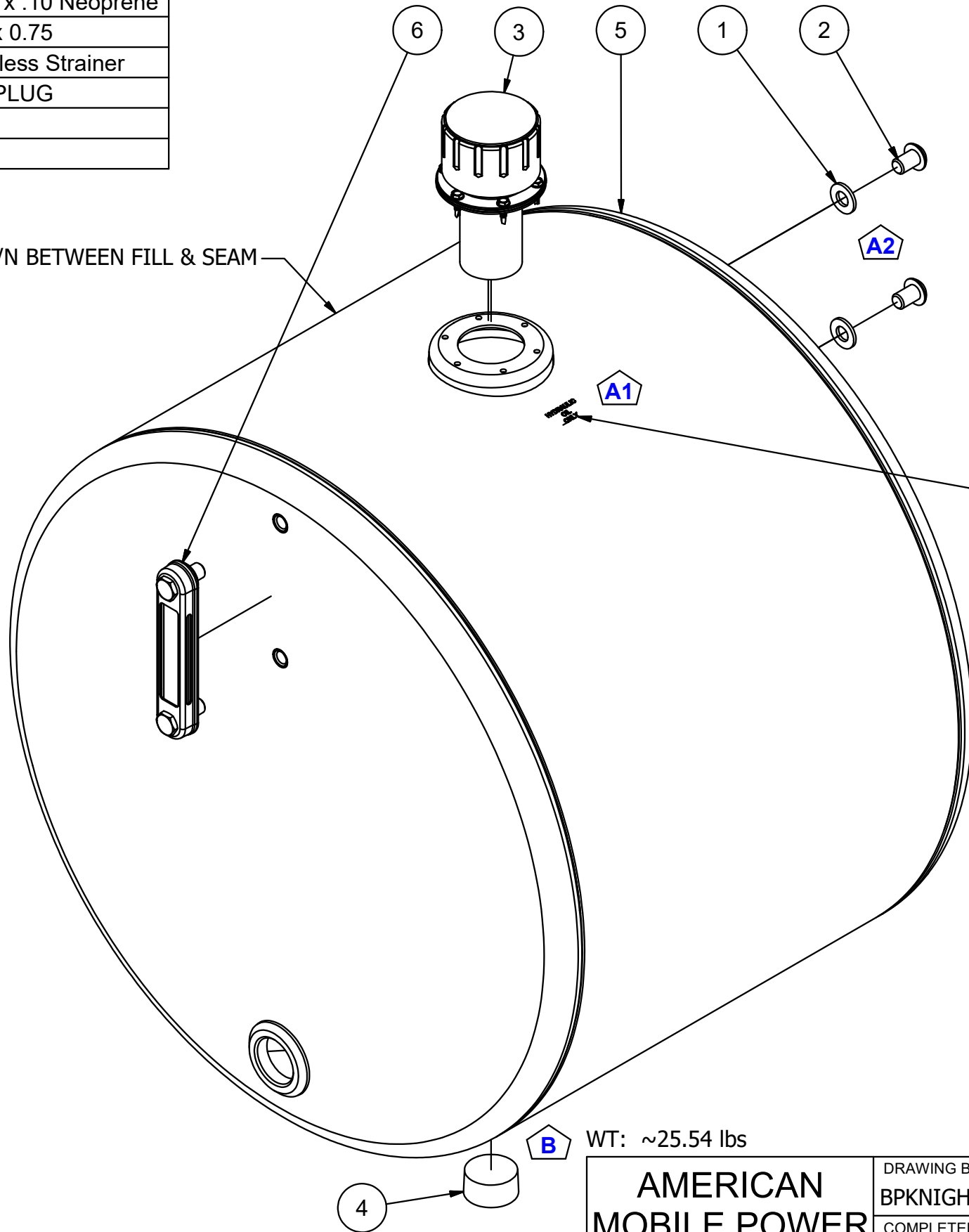

WT: ~25.54 lbs

DATE	SYM.	DESCRIPTION	BY
12-8-15	B	SHOW PLUG FOR WEIGHT	BPK
12-6-07	A2	Was STL FLT Washer, O-RING, Hex Hd. Cap Screw	BPK
12-6-07	A1	ADDED "HYDRAULIC OIL ONLY" STAMP	BPK

AMERICAN MOBILE POWER PH: (800) 634-8265 FAX: (765) 948-3403	DRAWING BY: BPKNIGHT	DESIGN FOR: A.M.P.	FILE NAME: A4535-ST	
	COMPLETED: 6/8/2007		SHEET: 1 of 5	SHEET SIZE: B

4

3

2

1

B

B

A

A

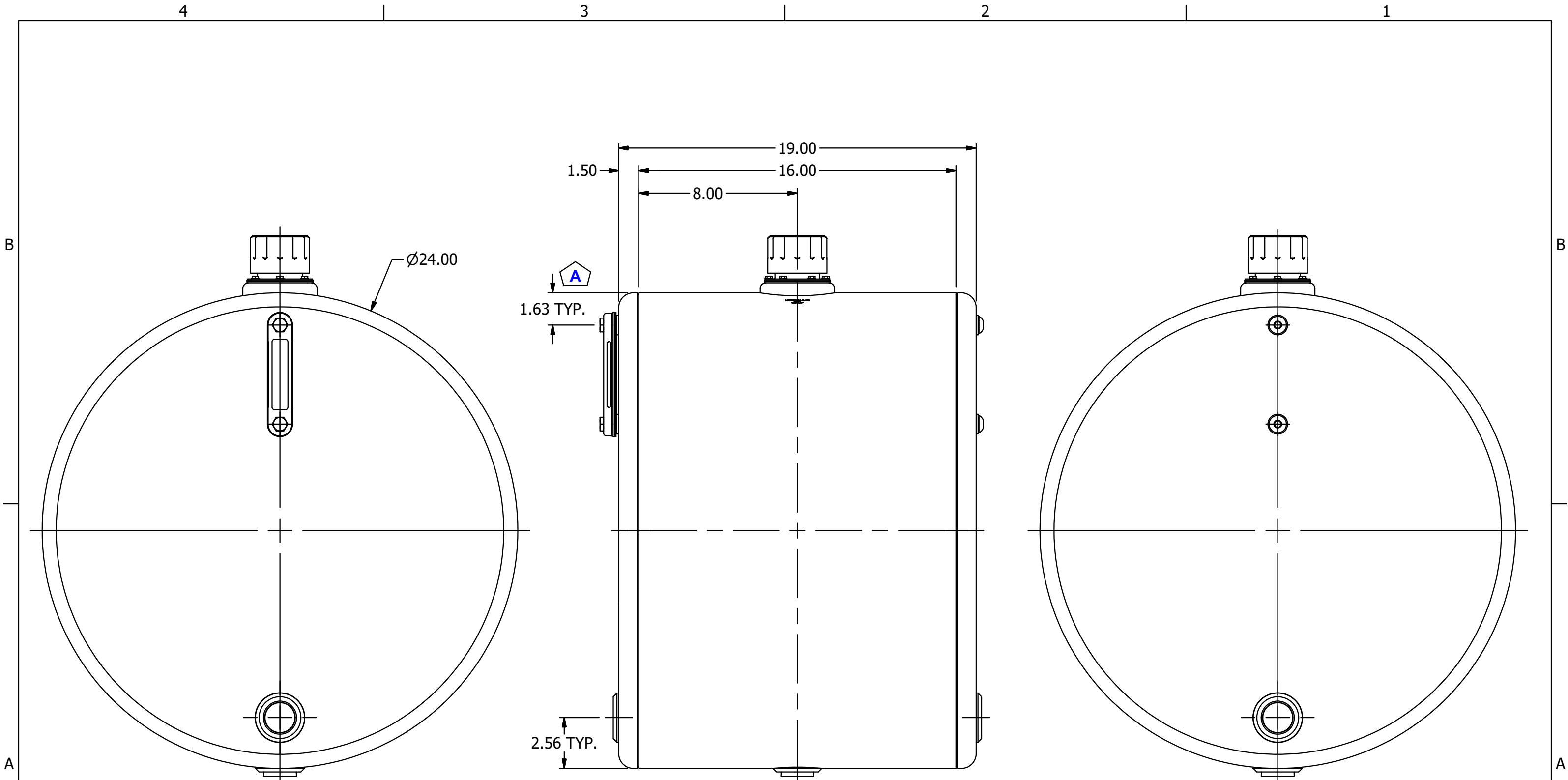

DATE	SYM.	DESCRIPTION	BY
4-20-09	A	WAS 2.00	BPK
REVISIONS			

**AMERICAN
MOBILE POWER**

PH: (800) 634-8265 FAX: (765) 948-3403

DRAWING BY:
BPKNIGHT

COMPLETED:
6/8/2007

DESIGN FOR:
A.M.P.

FILE NAME: A4535-ST	
SHEET: 2	SHEET SIZE: B
of 5	

4

3

2

1

Parts List

ITEM	QTY	PART NUMBER	DESCRIPTION	Fab Qty
1	4	0500-13-AWN	1/2-13 ALUMINUM WELD NUT	
2	1	A4535WS	.100 MILL ALUMINUM WRAP SHEET	
3	1	AFA-401	.100 AI FILL ASS'Y WELD FLANGE	
4	3	AWF1250RM	1-1/4" NPT AL WELD FLANGE REVERSE	
5	3	DIFFUSER-AL	.100 MILL ALUMINUM DIFFUSER	
6	2	SA1250RMST	24 IN X .100 MILL ALUMINUM HEAD	

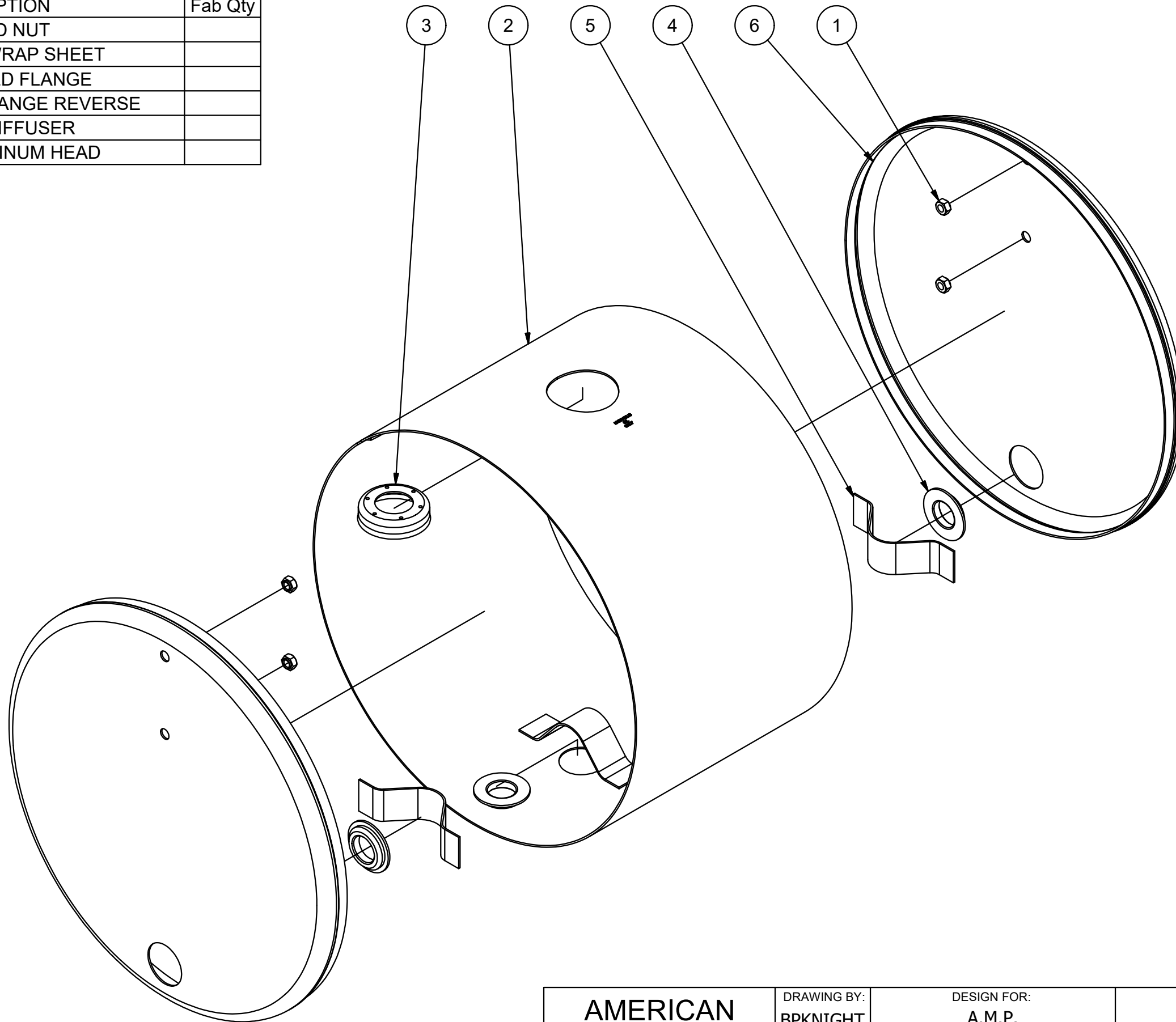

B

B

A

A

AMERICAN MOBILE POWER PH: (800) 634-8265 FAX: (765) 948-3403	DRAWING BY: BPKNIGHT	DESIGN FOR: A.M.P.	FILE NAME: A4535-ST	
	COMPLETED: 6/8/2007		SHEET: 3 of 5	SHEET SIZE: B

4

3

2

1