

4

3

2

1

Parts List

ITEM	QTY	PART NUMBER	DESCRIPTION
1	2	0500BBS	Black Buffer Seal 1.0 OD x .5 ID x .10 Neoprene
2	2	24107	Button Head, Hex, 1/2-13 UNC x 0.75
3	1	57XL-40	40 Micron FILL w/30 Mesh Stainless Strainer
4	1	ABA-138	3/8" NPT VENT
5	1	APP1250	1 1/4" NPT SQUARE SOCKET PLUG
6	1	N_A4500-ST	NAM WELDMENT ~30.33 lbs
7	1	T-LLG-5	SIGHT/TEMP. GAUGE, 5"

B AMP PARTS INCLUDE:
 -AMK-624-C MOUNTING KIT (STD) OR -S (UPGRADE)

NOTE:
 -PLUG ALL PORTS FOR SHIPMENT

S/N BETWEEN FILL & SEAM

HYDRAULIC OIL ONLY

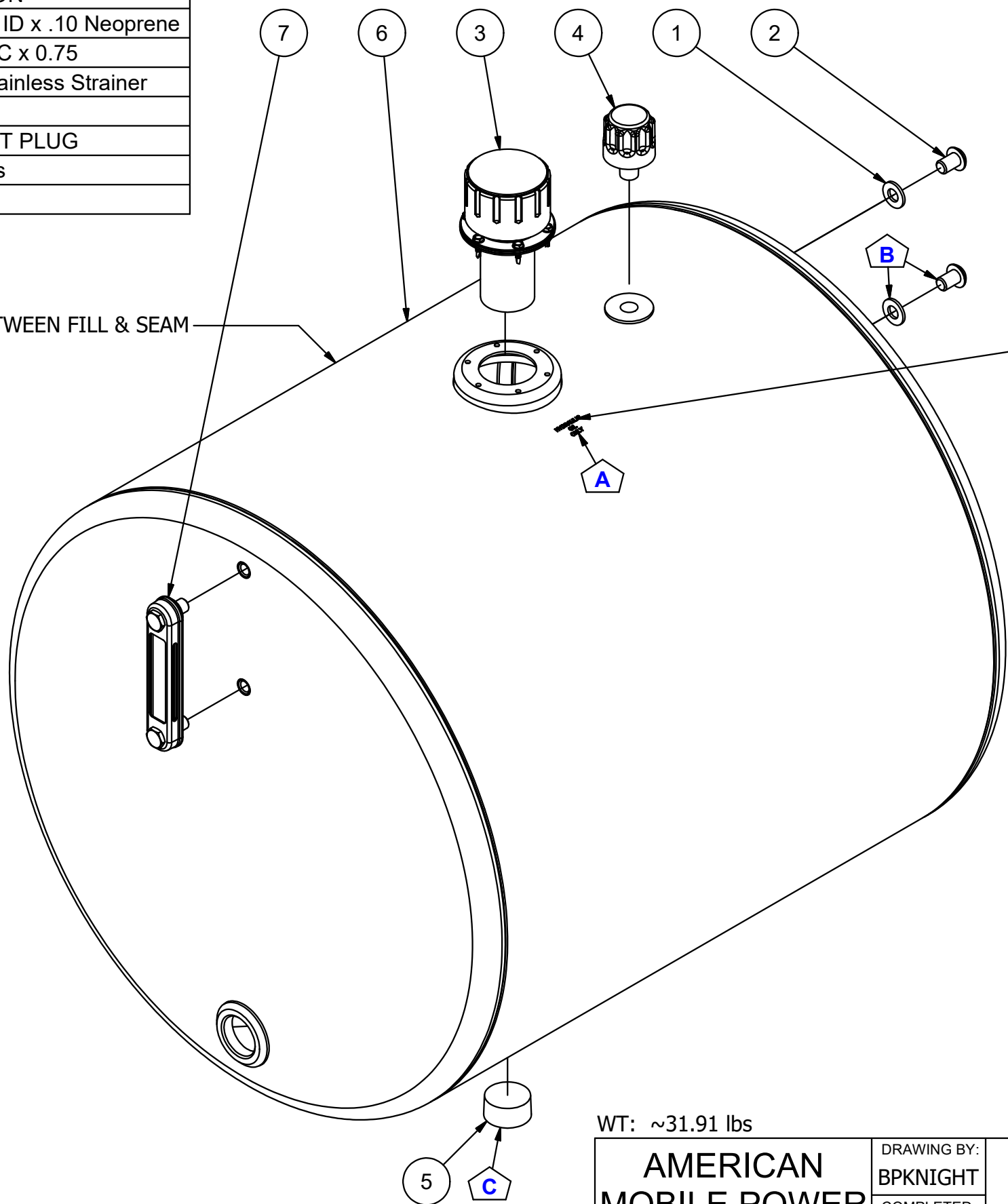

DATE	SYM.	DESCRIPTION	BY
9-18-14	C	ADD PLUG TO MODEL	BPK
12-6-07	B	Was STL FLT Washer, O_RING, Hex Hd Cap Screw	BPK
8-14-07	A	ADDED "HYDRAULIC OIL ONLY" STAMP	BPK
6-5-07	n/a	WAS A4500-STLH	BPK

WT: ~31.91 lbs

AMERICAN MOBILE POWER PH: (800) 634-8265 FAX: (765) 948-3403	DRAWING BY: BPKNIGHT	DESIGN FOR: A.M.P.	FILE NAME: A4500-ST	
	COMPLETED: 6/26/2006		SHEET: 1 of 5	SHEET SIZE: B

4

3

2

1

A

A

B

B

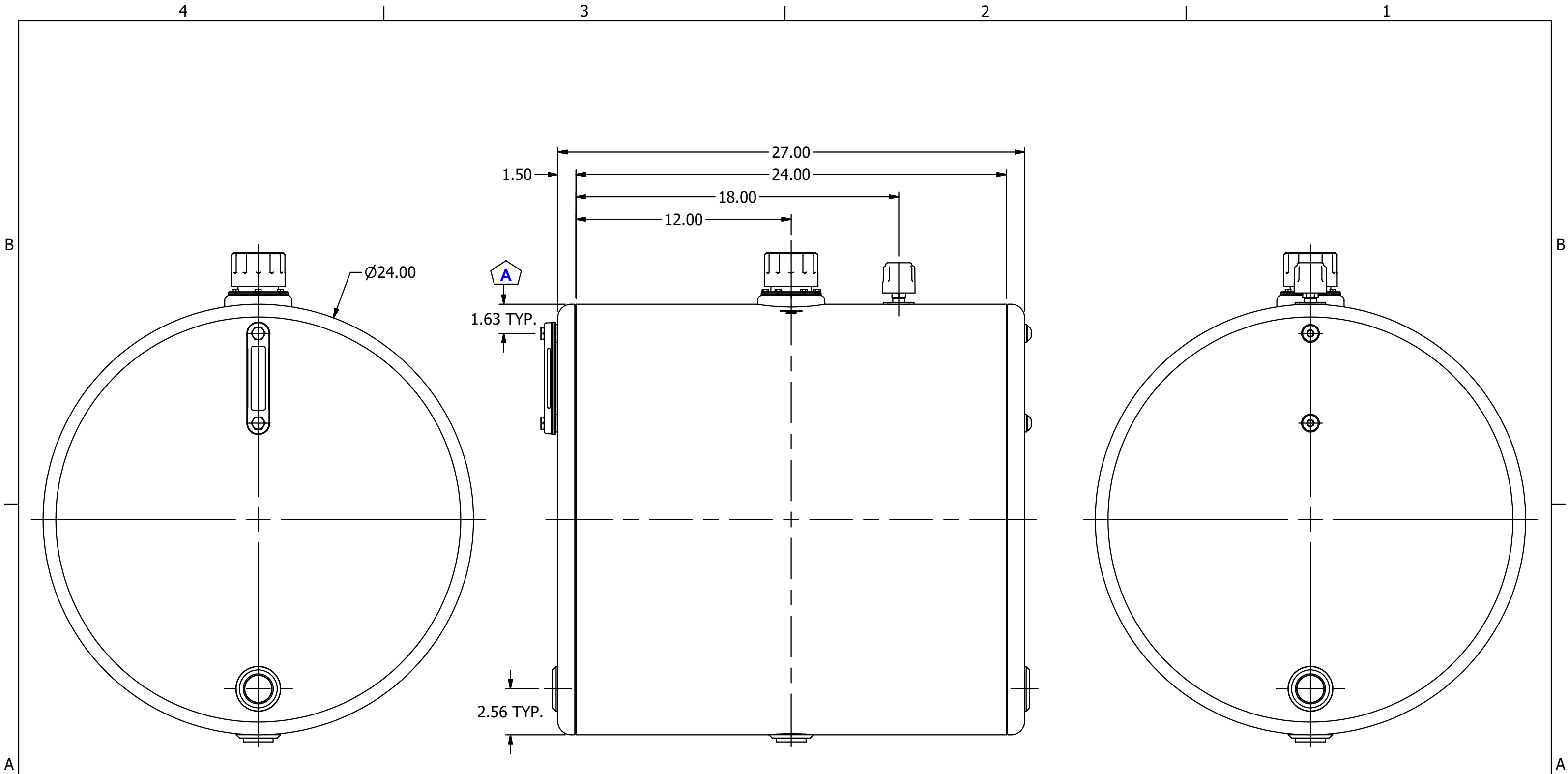

DATE	SYM.	DESCRIPTION	BY
4-17-09	A	WAS 2.00	BPK
REVISIONS			

**AMERICAN
MOBILE POWER**

PH: (800) 634-8265 FAX: (765) 948-3403

DRAWING BY:
BPKNIGHT

COMPLETED:
6/26/2006

DESIGN FOR:
A.M.P.

FILE NAME: A4500-ST	
SHEET: 2	SHEET SIZE: B
of 5	

4

3

2

1

Parts List

ITEM	QTY	PART NUMBER	DESCRIPTION	Fab Qty
1	4	0500-13-AWN	1/2-13 ALUMINUM WELD NUT	
2	1	A4500WS	.100 MILL ALUMINUM WRAP SHEET	
3	1	AFA-401	.100 AI FILL ASS'Y WELD FLANGE	
4	1	AWF0375SA	3/8" NPT ALUMINUM WELD FLANGE	
5	3	AWF1250RM	1-1/4" NPT AL WELD FLANGE REVERSE	
6	3	DIFFUSER-AL	.100 MILL ALUMINUM DIFFUSER	
7	2	SA1250RMST	24 IN X .100 MILL ALUMINUM HEAD	

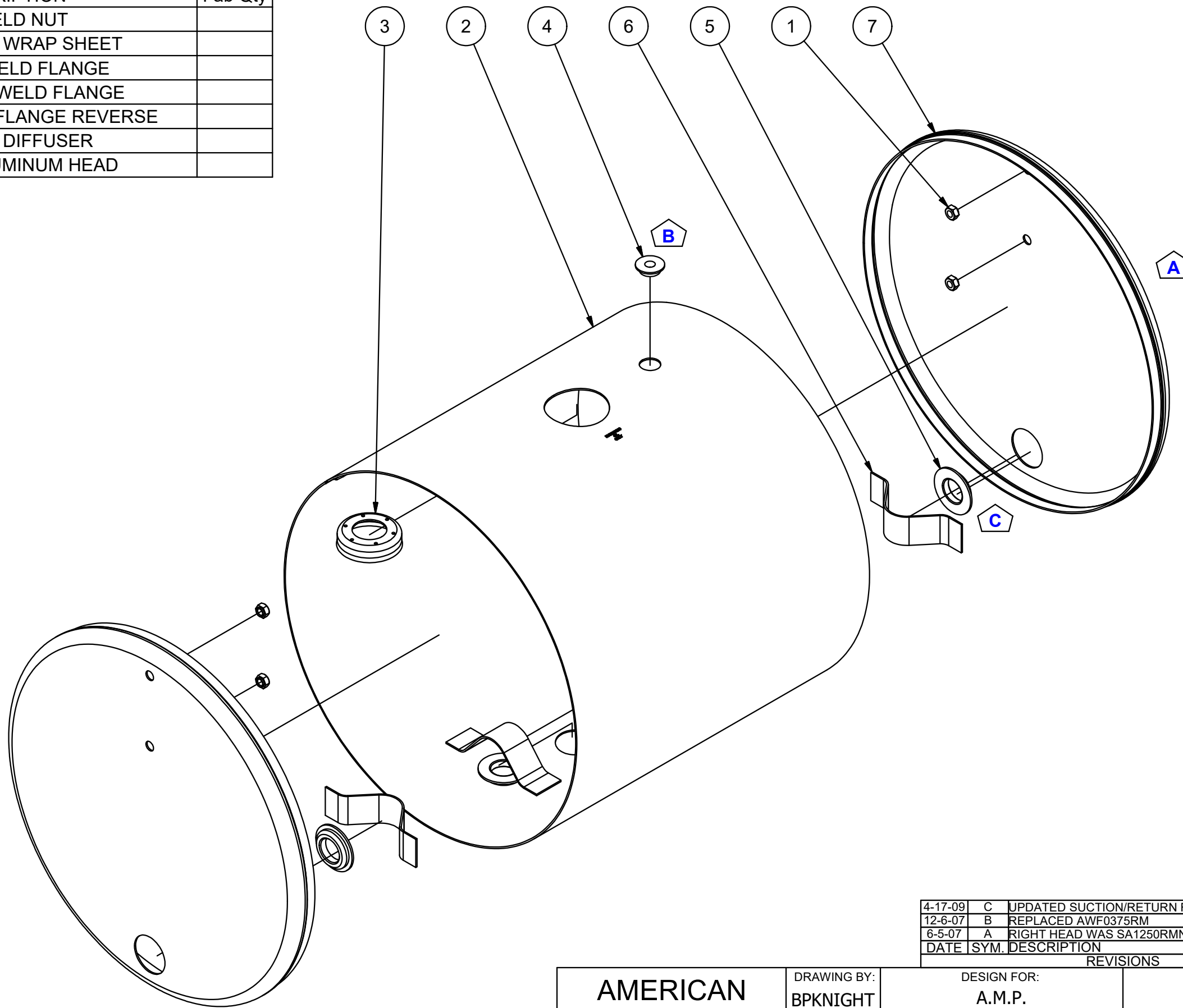

B

B

A

A

DATE	SYM.	DESCRIPTION	BY
4-17-09	C	UPDATED SUCTION/RETURN FLANGES	BPK
12-6-07	B	REPLACED AWF0375RM	BPK
6-5-07	A	RIGHT HEAD WAS SA1250RMNS	BPK

REVISIONS

AMERICAN MOBILE POWER PH: (800) 634-8265 FAX: (765) 948-3403	DRAWING BY: BPKNIGHT	DESIGN FOR: A.M.P.	FILE NAME: A4500-ST	
	COMPLETED: 6/26/2006		SHEET: 3 of 5	SHEET SIZE: B

4

3

2

1