

4

3

2

1

Parts List

ITEM	QTY	PART NUMBER	DESCRIPTION
1	1	57XL-40	40 Micron FILL w/30 Mesh Stainless Strainer
2	2	BF-16	1" NPT VENT
3	1	N_A40100ST	NAM WELDMENT ~110.08 lbs
4	1	T-LLG-5	SIGHT/TEMP. GAUGE, 5"

AMP PARTS INCLUDE:
 -ASK-210 HEAVY DUTY CHASSIS MOUNTING KIT

NOTE:
 -PLUG ALL PORTS FOR SHIPMENT

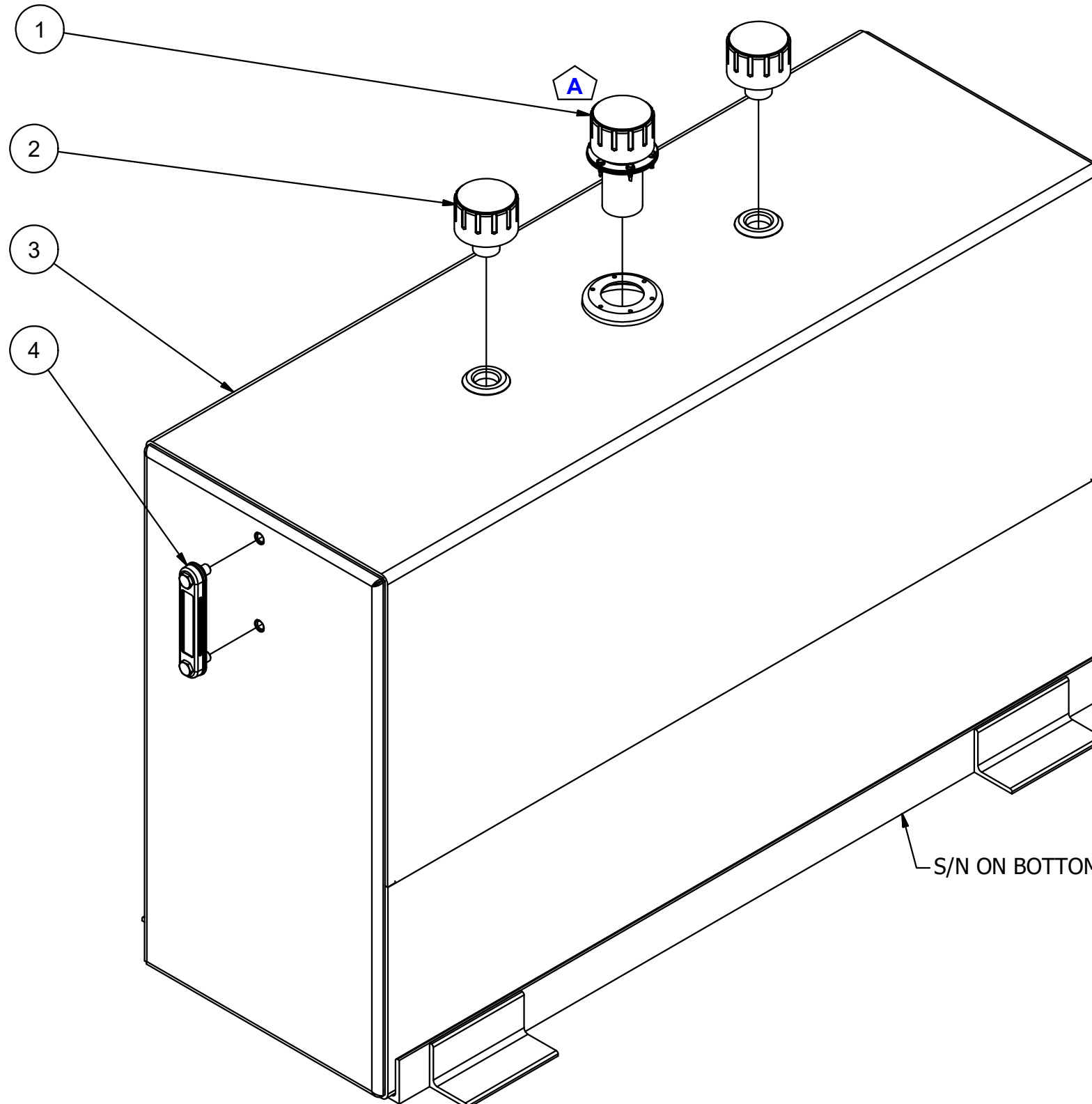

B

B

A

A

4

3

2

1

8-24-16	A	FILLER WAS 57XL-40N	BPK
DATE	SYM.	DESCRIPTION	BY

REVISIONS

AMERICAN MOBILE POWER PH: (800) 634-8265 FAX: (765) 948-3403	DRAWING BY: BPKNIGHT	DESIGN FOR: AMP	FILE NAME: A40100ST	
	COMPLETED: 8/30/2007		SHEET: 1 of 11	SHEET SIZE: B

4 3 2 1

B

B

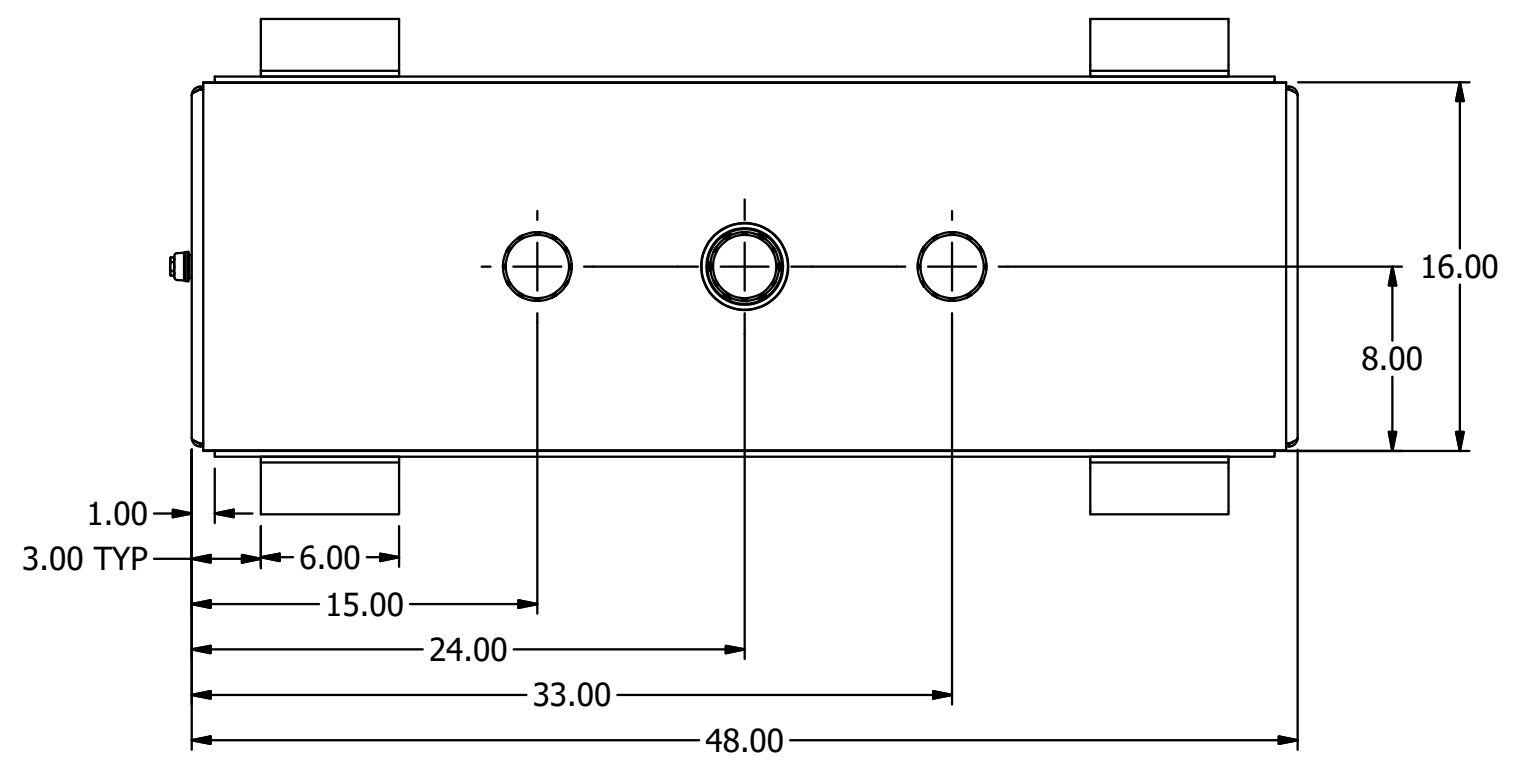

A

A

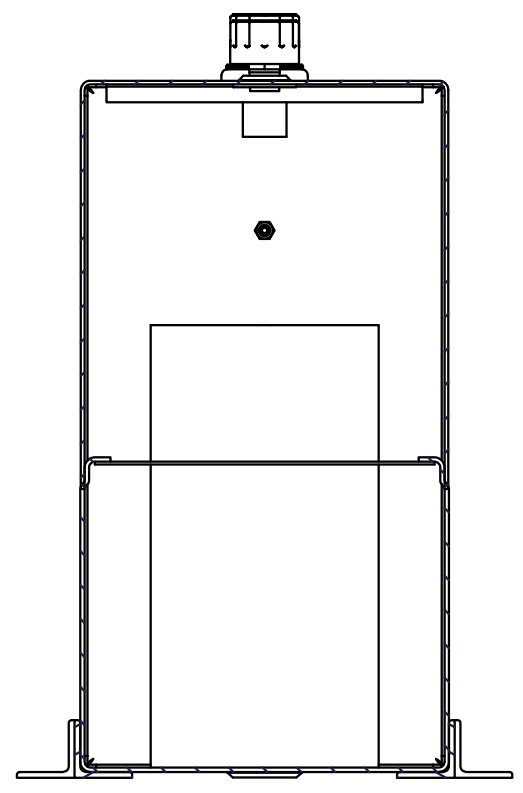
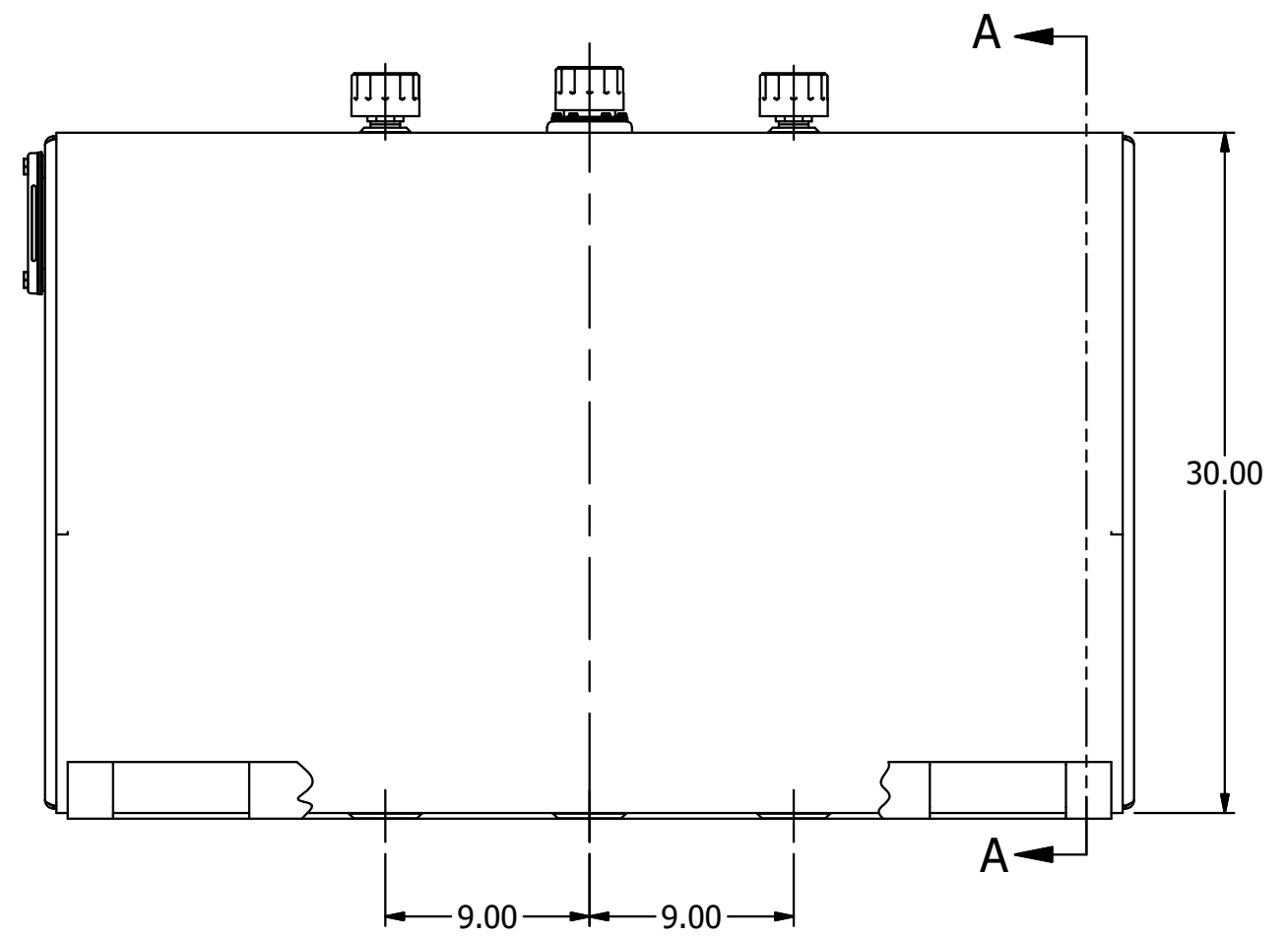
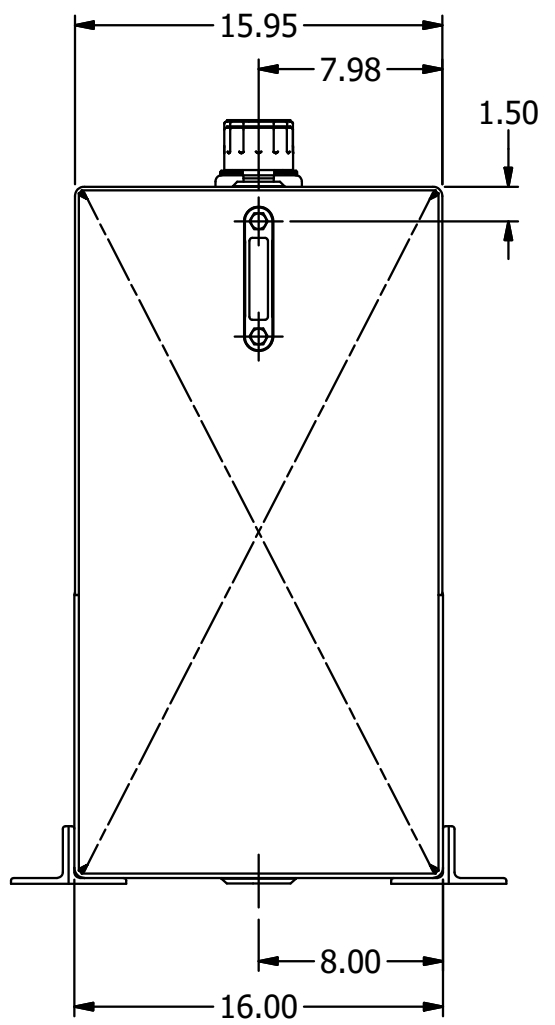

SECTION A-A

AMERICAN MOBILE POWER PH: (800) 634-8265 FAX: (765) 948-3403	DRAWING BY: BPKNIGHT	DESIGN FOR: AMP	FILE NAME: A40100ST	
	COMPLETED: 8/30/2007		SHEET: 2 of 11	SHEET SIZE: B

4 3 2 1

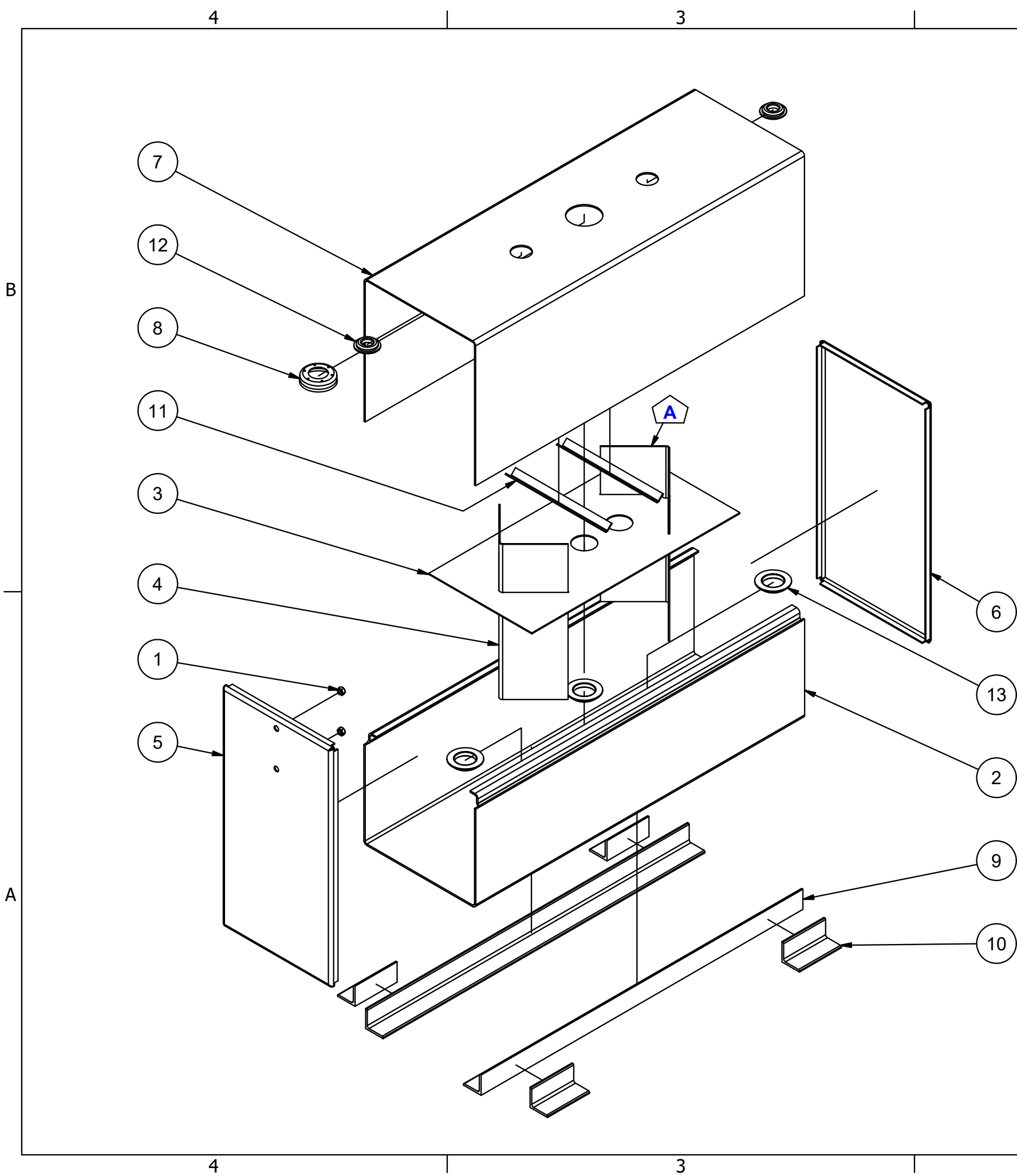

Parts List				
ITEM	QTY	PART NUMBER	DESCRIPTION	Fab Qty
1	2	0500-13-AWN	1/2-13 ALUMINUM WELD NUT	
2	1	A40100STB	.190 MILL ALUMINUM BOTTOM SECTION	
3	1	A40100STH	.125 MILL ALUM. BAFFLE HORIZ.	
4	2	A40100STI	.125 MILL ALUM. BAFFLE INSERT	
5	1	A40100STL	.125 MILL ALUMINUM LEFT HEAD	
6	1	A40100STR	.125 MILL ALUMINUM RIGHT HEAD	
7	1	A40100STT	.125 TREAD BRITE ALUM. TOP SECTION	
8	1	AFA-401	.100 AI FILL ASS'Y WELD FLANGE	
9	2	ANGLE-A40100	2 1/2 x 2 1/2 x 1/4 x 46 LG ALUM ANGLE	
10	4	ANGLE-AL25-6IN	2 1/2 x 2 1/2 x 1/4 x 6 LG ALUM ANGLE	
11	2	ASTF13-4137	.125 MILL ALUM. x13.714 STIFFENER	
12	2	AWF1000RM	1" NPT ALUM. WELD FLANGE REVERSE	
13	3	AWF2000RM	2" NPT ALUM. WELD FLANGE REVERSE	

DATE	SYM.	DESCRIPTION	BY
12-19-16	A	ADD STIFF'S TO TOP	BPK

AMERICAN MOBILE POWER PH: (800) 634-8265 FAX: (765) 948-3403	DRAWING BY: BPKNIGHT	DESIGN FOR: AMP	FILE NAME: A40100ST	
	COMPLETED: 8/30/2007		SHEET: 3 of 11	SHEET SIZE: B