

Parts List

ITEM	QTY	PART NUMBER	DESCRIPTION
1	2	0500BBS	Black Buffer Seal 1.0 OD x .5 ID x .10 Neoprene
2	2	24107	Button Head, Hex, 1/2-13 UNC x 0.75
3	1	57XL-40	40 Micron FILL w/30 Mesh Stainless Strainer
4	1	APP1250	1 1/4" NPT SQUARE SOCKET PLUG
5	1	N_A3535-ST	NAM WELDMENT ~59.81 lbs
6	1	T-LLG-5	SIGHT/TEMP. GAUGE, 5"

AMP PARTS INCLUDE:

-AMK-624-C MOUNTING KIT (STD) OR -S (UPGRADE)

S/N BETWEEN FILL & SEAM

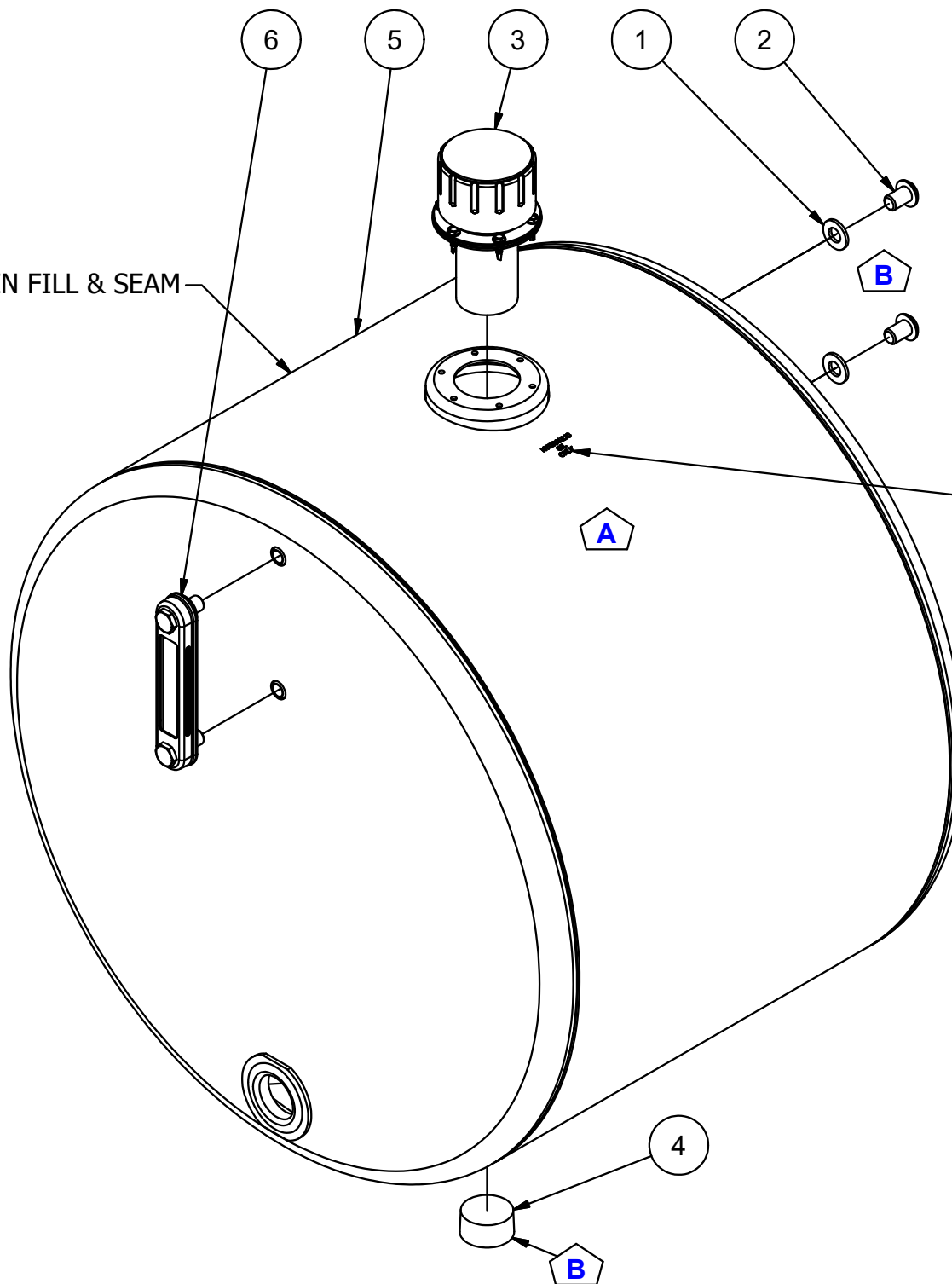

HYDRAULIC OIL ONLY

WT: ~61.13 lbs

DATE	SYM.	DESCRIPTION	BY
12-12-16	C	SHOW PLUG & WT	BPK
12-12-07	B	Was O-Ring, STL FLT Washer, HHCS	BPK
12-12-07	A	ADDED "HYDRAULIC OIL ONLY" STAMP	BPK

REVISIONS

<b>AMERICAN MOBILE POWER</b> PH: (800) 634-8265 FAX: (765) 948-3403	DRAWING BY: <b>BPKNIGHT</b>	DESIGN FOR: <b>A.M.P.</b>	FILE NAME: <b>A3535-ST</b>	
	COMPLETED: <b>6/7/2007</b>		SHEET: <b>1 of 5</b>	SHEET SIZE: <b>B</b>

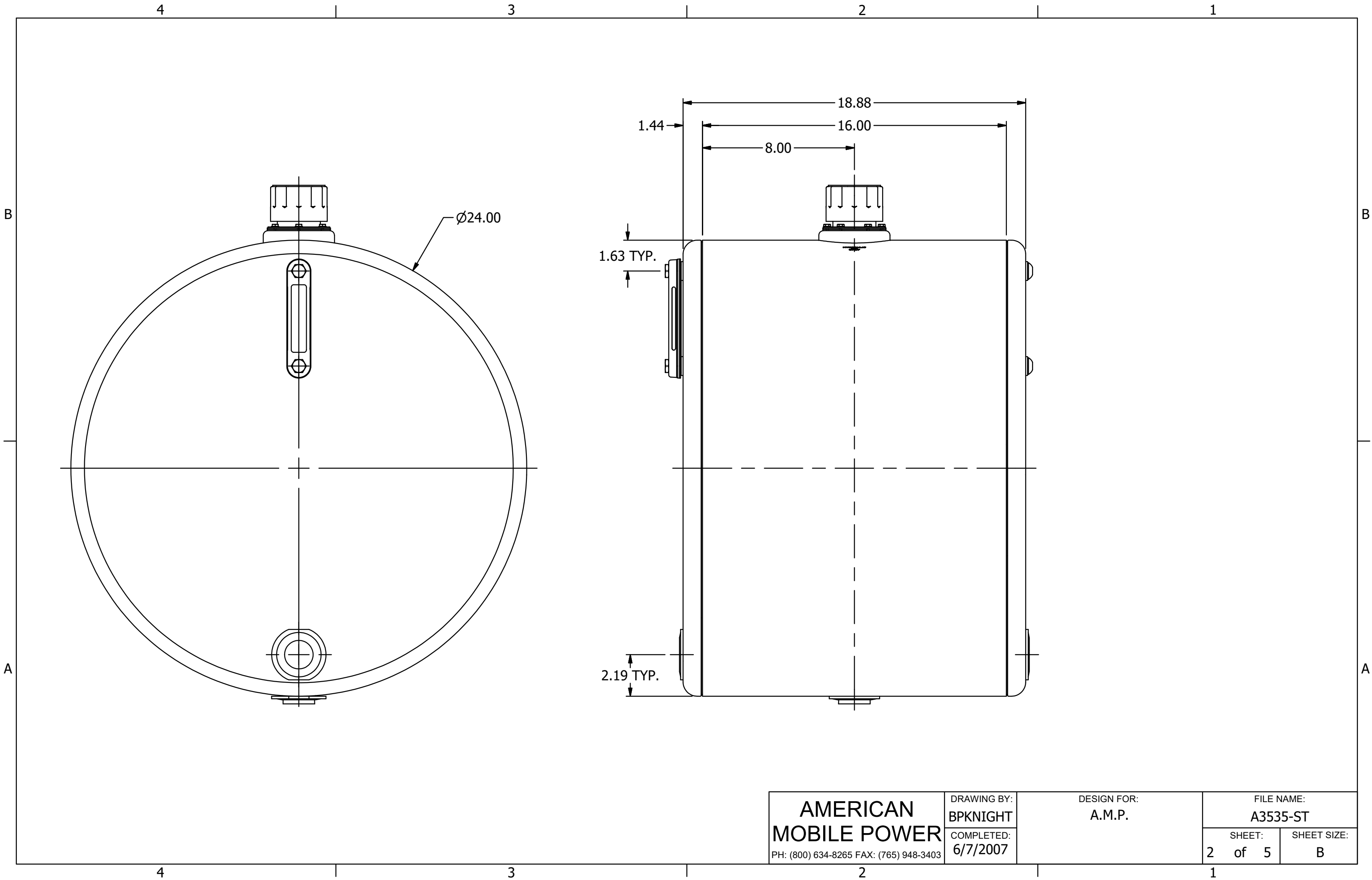

**AMERICAN  
MOBILE POWER**  
PH: (800) 634-8265 FAX: (765) 948-3403

DRAWING BY:  
**BPKNIGHT**  
COMPLETED:  
**6/7/2007**

DESIGN FOR:  
**A.M.P.**

FILE NAME: <b>A3535-ST</b>	
SHEET: <b>2 of 5</b>	SHEET SIZE: <b>B</b>

4

3

2

1

Parts List

ITEM	QTY	PART NUMBER	DESCRIPTION	Fab Qty
1	4	0500-13-FWN	1/2"-13 UNC WELD NUT	
2	1	A3535WS	14 GA HRPO WRAP SHEET	
3	1	AFS-301	13 GA HRPO Fill Ass'y Weld Flange	
4	3	DIFFUSER-ST	13 GA HRPO DIFFUSER	
5	2	SS1250ST	24 IN, 13 GA HRPO HEAD	
6	2	SWF1250	1 1/4" NPSC STEEL WELD FLANGE	
7	1	SWF1250C	1 1/4" NPSC STL WELD FLANGE, CURVED	

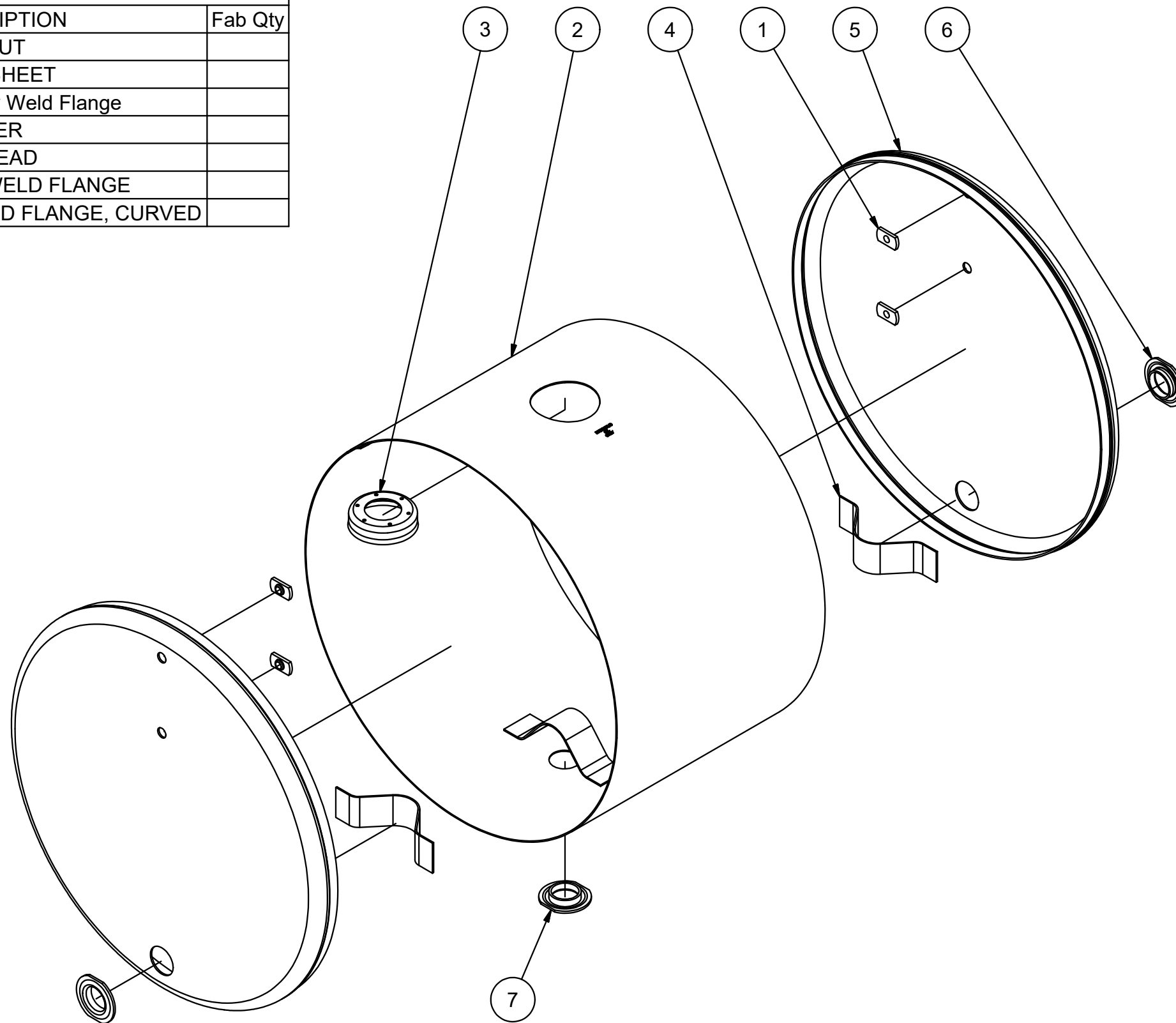

B

B

A

A

<b>AMERICAN MOBILE POWER</b> PH: (800) 634-8265 FAX: (765) 948-3403	DRAWING BY: BPKNIGHT	DESIGN FOR: A.M.P.	FILE NAME: A3535-ST	
	COMPLETED: 6/7/2007		SHEET: 3 of 5	SHEET SIZE: B

4

3

2

1