

4

3

2

1

Parts List

ITEM	QTY	PART NUMBER	DESCRIPTION
1	2	0500BBS	Black Buffer Seal 1.0 OD x .5 ID x .10 Neoprene
2	2	24107	Button Head, Hex, 1/2-13 UNC x 0.75
3	1	57XL-40	40 Micron FILL w/30 Mesh Stainless Strainer
4	1	APP0750-M	3/4" NPT MAG PLUG
5	1	N_A3535-DS90-ST	NAM WELDMENT ~64 1/2 lbs
6	1	T-LLG-5	SIGHT/TEMP. GAUGE, 5"

AMP PARTS INCLUDE:

-AMK-624-C MOUNTING KIT (STD) OR -S (UPGRADE)

NOTES:

- POWDER COAT BLACK
- APPLY RUST INHIBITOR INSIDE
- PLUG ALL PORTS FOR SHIPMENT

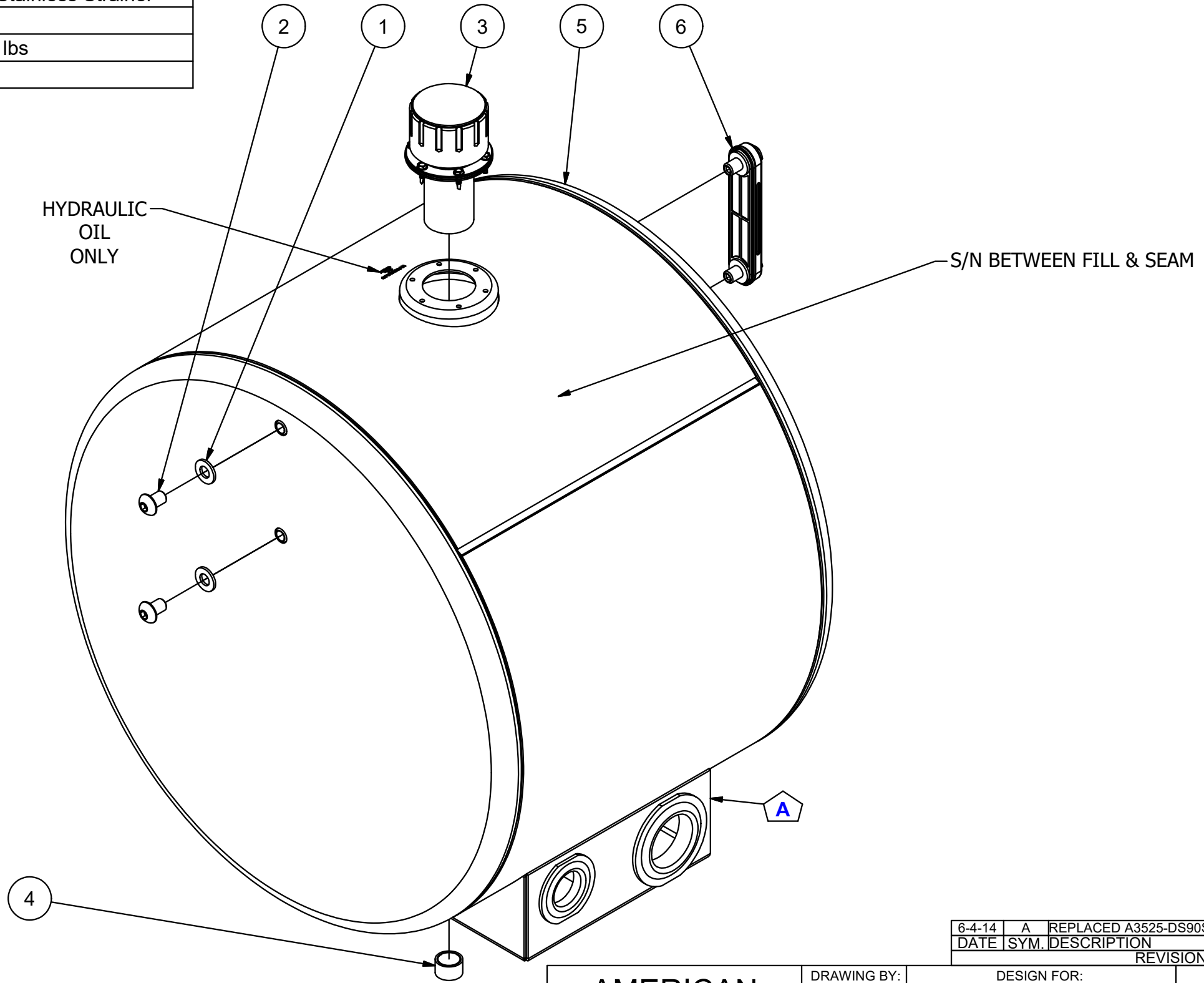

DATE	SYM.	DESCRIPTION	BY
6-4-14	A	REPLACED A3525-DS90SP	BPK

REVISIONS

<b>AMERICAN MOBILE POWER</b> PH: (800) 634-8265 FAX: (765) 948-3403	DRAWING BY: BPKNIGHT	DESIGN FOR: AMP	FILE NAME: A3535-DS90-ST	
	COMPLETED: 3/19/2013		SHEET: 1 of 9	SHEET SIZE: B

4

3

2

1

B

B

A

A

4

3

2

1

B

B

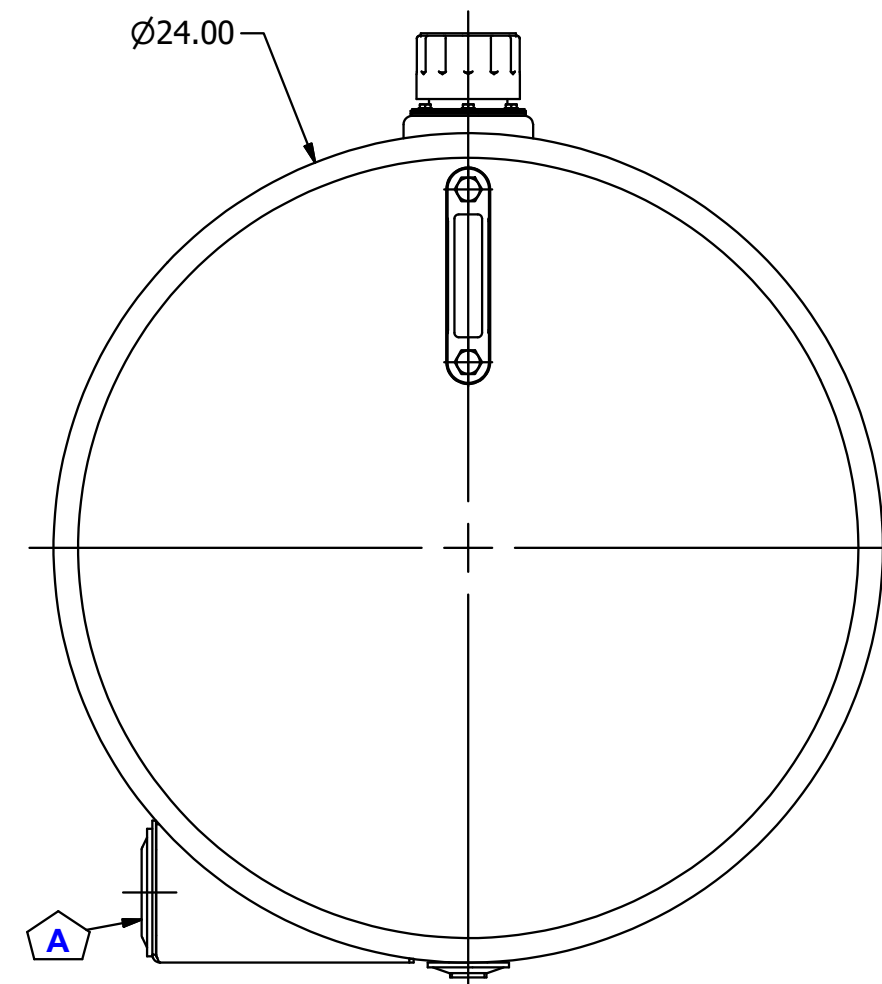
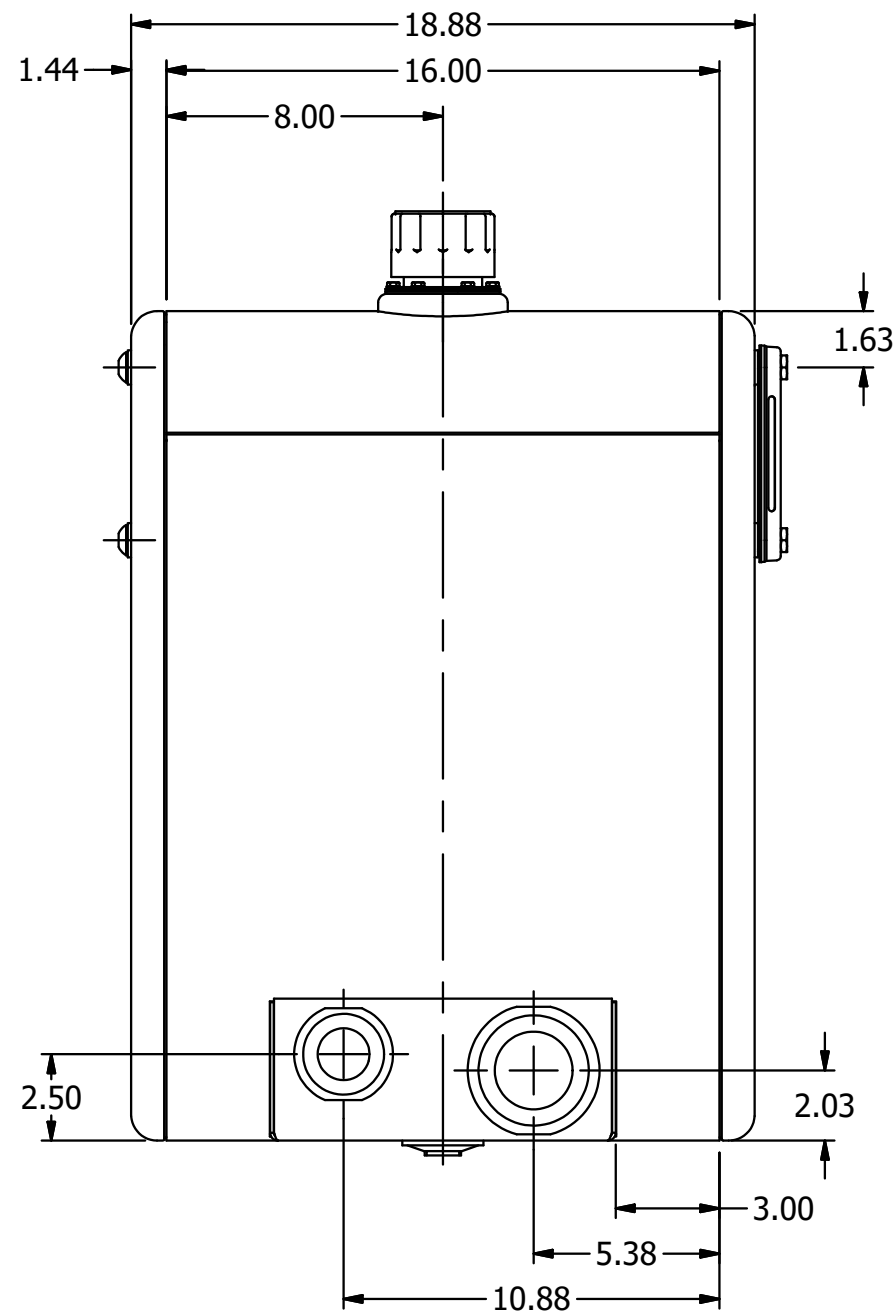
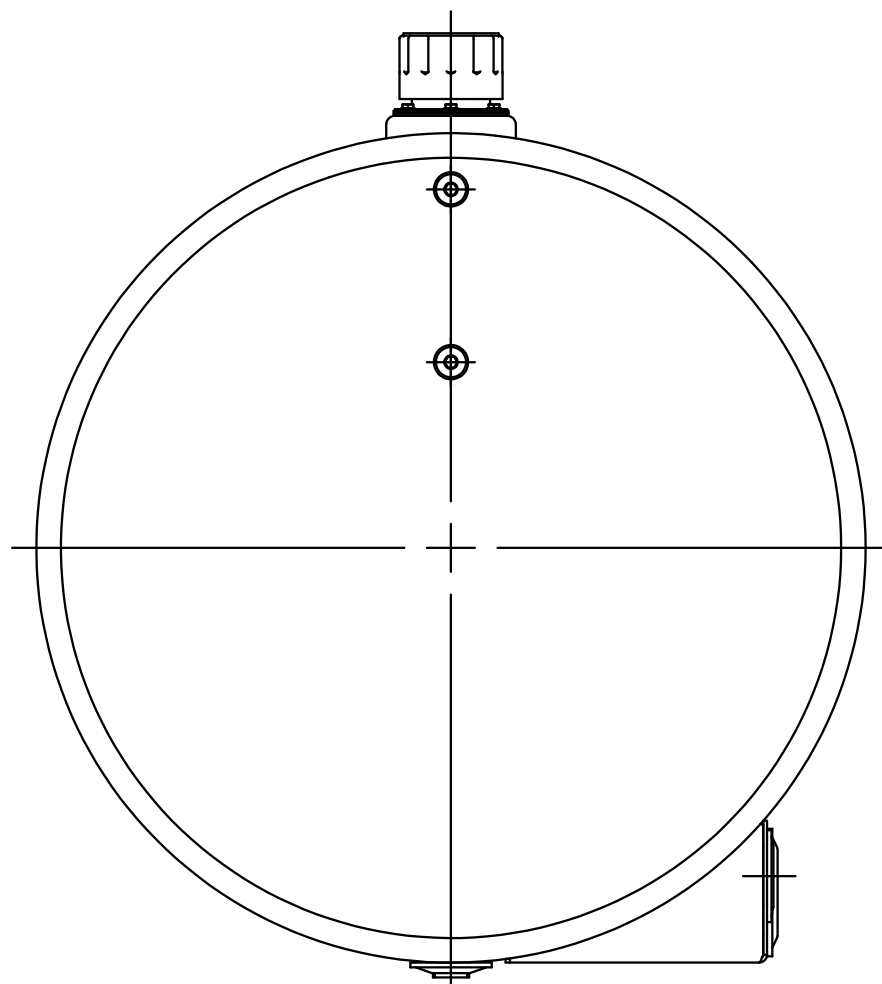

A

A

DATE	SYM.	DESCRIPTION	BY
6-4-14	A	REPLACED A3525-DS90SP	BPK

REVISIONS

<b>AMERICAN MOBILE POWER</b> PH: (800) 634-8265 FAX: (765) 948-3403	DRAWING BY: <b>BPKNIGHT</b>	DESIGN FOR: <b>AMP</b>	FILE NAME: <b>A3535-DS90-ST</b>	
	COMPLETED: <b>3/19/2013</b>		SHEET: <b>2 of 9</b>	SHEET SIZE: <b>B</b>

4

3

2

1

4

3

2

1

Parts List

ITEM	QTY	PART NUMBER	DESCRIPTION	Fab Qty
1	4	0500-13-FWN	1/2"-13 UNC WELD NUT	
2	1	A3535-DS90WS	14 GA HRPO WRAP SHEET	
3	1	AFS-301	13 GA HRPO Fill Ass'y Weld Flange	
4	1	N_A3535-DS90SP	WELDMENT: 1 1/4" NPT SUCTION PORT	
5	2	SS0000ST	13 GA HRPO SIGHT/GAUGE HEAD	
6	1	SWF0750	3/4" NPTF STEEL WELD FLANGE	

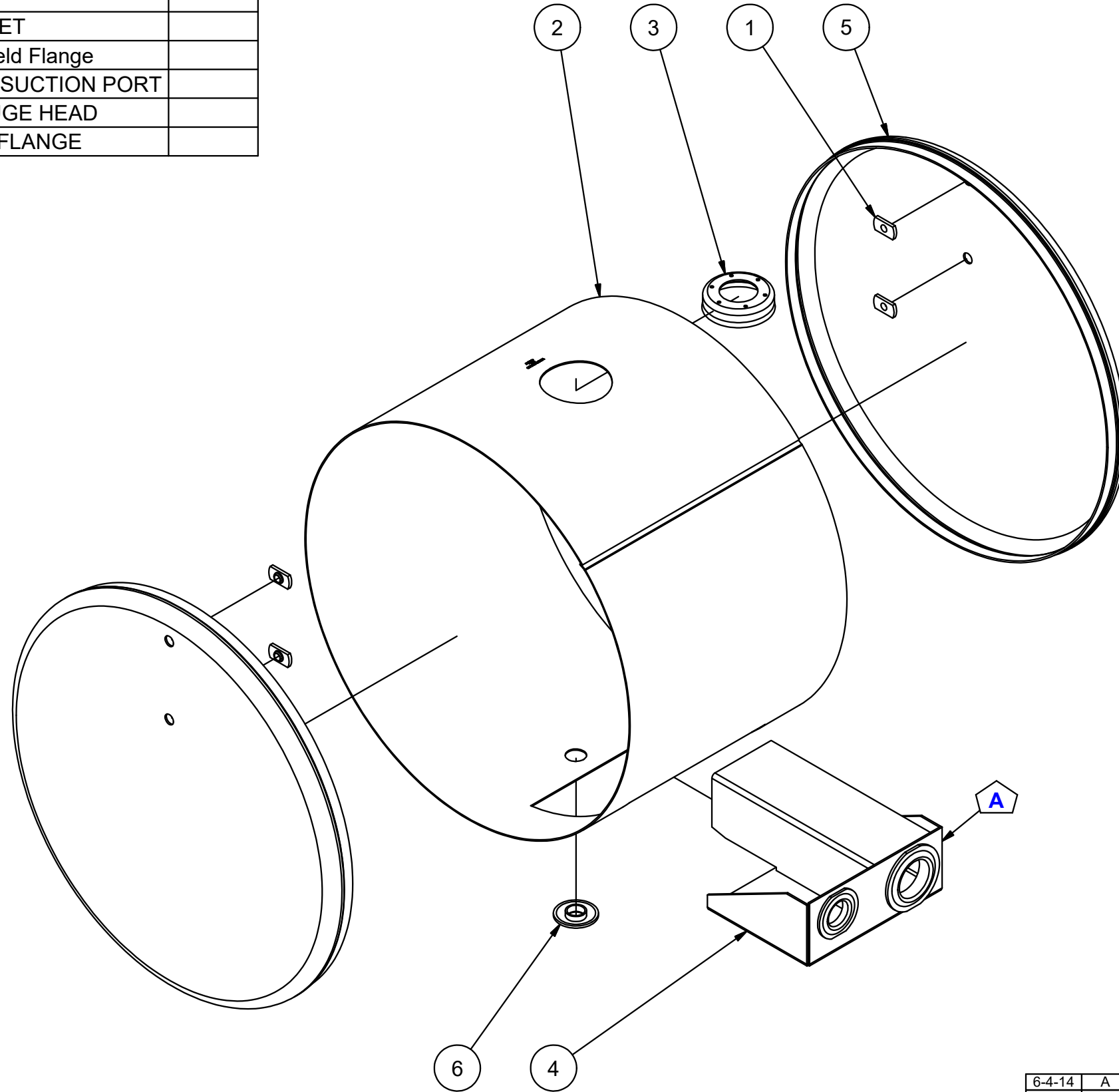

DATE	SYM.	DESCRIPTION	BY
6-4-14	A	REPLACED A3525-DS90SP	BPK

REVISIONS

<b>AMERICAN MOBILE POWER</b> PH: (800) 634-8265 FAX: (765) 948-3403	DRAWING BY: <b>BPKNIGHT</b>	DESIGN FOR: <b>AMP</b>	FILE NAME: <b>A3535-DS90-ST</b>	
	COMPLETED: <b>3/19/2013</b>		SHEET: <b>3 of 9</b>	SHEET SIZE: <b>B</b>

4

3

2

1

B

B

A

A