

Parts List			
ITEM	QTY	PART NUMBER	DESCRIPTION
1	4	13309	5/8-11 UNC x 1.5 Hex Cap Screw
2	8	33016	1 3/4 x 11/16 x 1/8 Thk Steel Plain Washer
3	4	37036	5/8 Std NC Nylock Nut
4	1	57XL-40	40 Micron FILL w/30 Mesh Stainless Strainer
5	1	AFC-507	FILTER PORT COVER 6.25 DIA. B.C.
6	2	AMA-14MFG-2L	2 x 2 x 1/4" MFG ANGLE, 2 Legs Punched
7	1	APP0750-M	3/4" NPT MAG PLUG
8	1	N_A325SL	14.78W21H19D NAM WELDMENT ~97 3/4 lbs
9	1	T-LLG-5	SIGHT/TEMP. GAUGE, 5"

\* ON ORDER ONLY: LIT-1250-10P IN-TANK RETURN FILTER

NOTES:  
 -POWDER COAT BLACK  
 -APPLY RUST INHIBITOR INSIDE  
 -PLUG ALL PORTS FOR SHIPMENT  
 ANGLES AND FASTENERS SHIP LOOSE

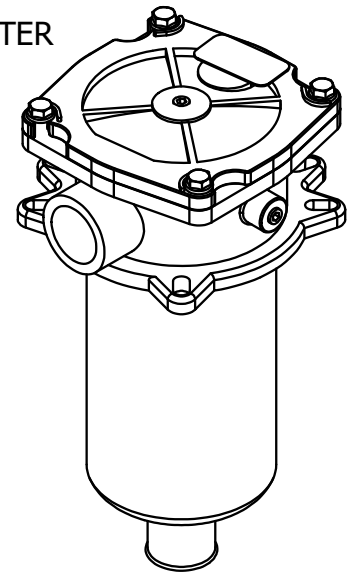

STAMP SERIAL No. HERE

DATE	SYM.	DESCRIPTION	BY
9-13-18	N/A	ADDED S/N NOTE	BPK
11-24-15	C	DEL. OPTIONAL FILTER; SHOW COVER	BPK
11-1-13	B	ADD SUPPORT PLATE; REV. BAFFLE	BPK
4-19-12	A	AFF-3-1250 REPLACES 0375-16-FWN's	BPK

WT: ~107.85 lbs

<b>AMERICAN MOBILE POWER</b> PH: (800) 634-8265 FAX: (765) 948-3403	DRAWING BY: <b>BPKNIGHT</b>	DESIGN FOR: <b>AMP</b>	FILE NAME: <b>A325SL</b>	
	COMPLETED: <b>4/30/2008</b>		SHEET: <b>1 of 8</b>	SHEET SIZE: <b>B</b>

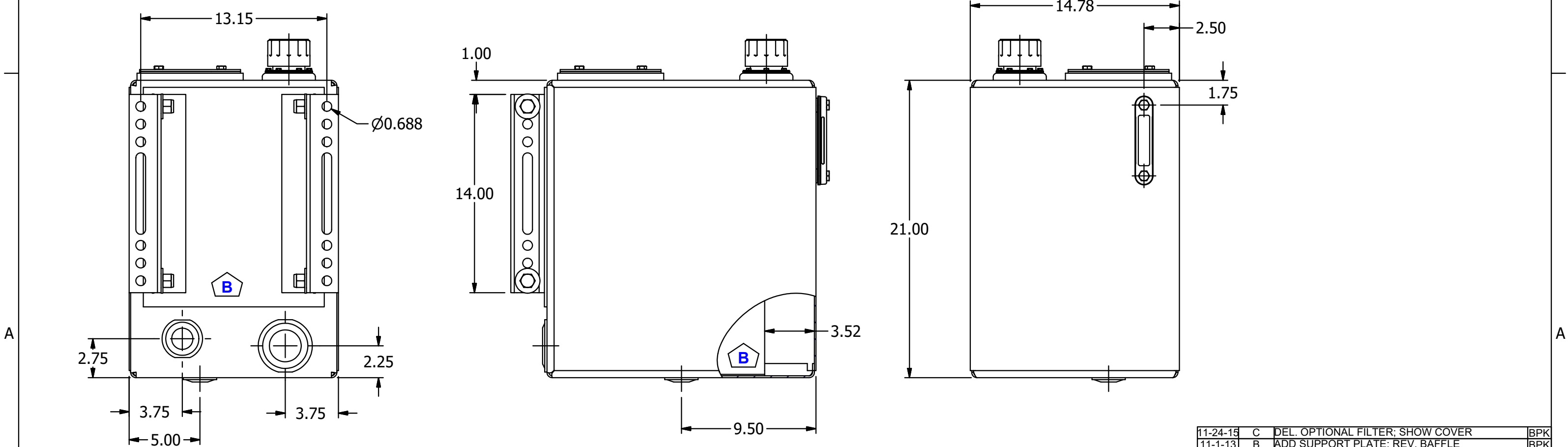
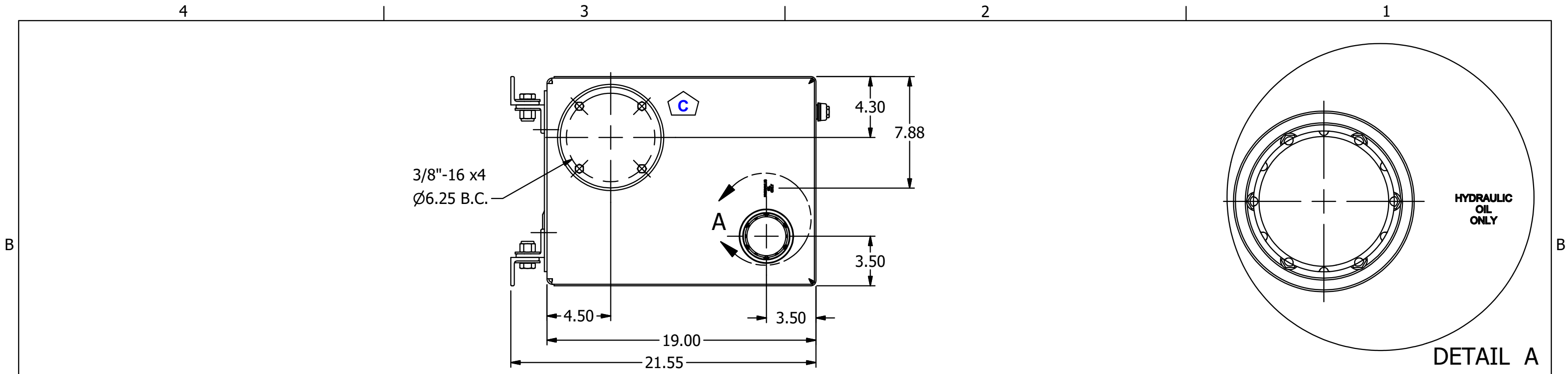

DATE	SYM.	DESCRIPTION	BY
11-24-15	C	DEL. OPTIONAL FILTER; SHOW COVER	BPK
11-1-13	B	ADD SUPPORT PLATE; REV. BAFFLE	BPK

REVISIONS			
<b>AMERICAN MOBILE POWER</b> PH: (800) 634-8265 FAX: (765) 948-3403	DRAWING BY: <b>BPKNIGHT</b>	DESIGN FOR: <b>AMP</b>	FILE NAME: <b>A325SL</b>
	COMPLETED: <b>4/30/2008</b>		SHEET: <b>2 of 8</b>
			SHEET SIZE: <b>B</b>

4

3

2

1

Parts List

ITEM	QTY	PART NUMBER	DESCRIPTION	Fab Qty
1	2	0500-13-FWN	1/2"-13 UNC WELD NUT	
2	1	A325SLBB	10 GA HRPO BACK SHEET	
3	1	A325SLBF	12 GA HRPO BAFFLE	
4	1	A325SLFS	12 GA HRPO SIDE-FRONT-SIDE	
5	1	A330SLPB	7 GA HRPO SUPPORT PLATE	
6	1	AFF-3-1250	.50 x 7.5 O.D. HRPO Filter Flange	
7	1	AFS-301	13 GA HRPO Fill Ass'y Weld Flange	
8	2	ANGLE14MFG	2 X 2 X 1/4" MFG ANGLE	
9	1	SWF0750	3/4" NPTF STEEL WELD FLANGE	
10	1	SWF1250	1 1/4" NPSC STEEL WELD FLANGE	
11	1	SWF2000	2" NPSC STEEL WELD FLANGE	

B

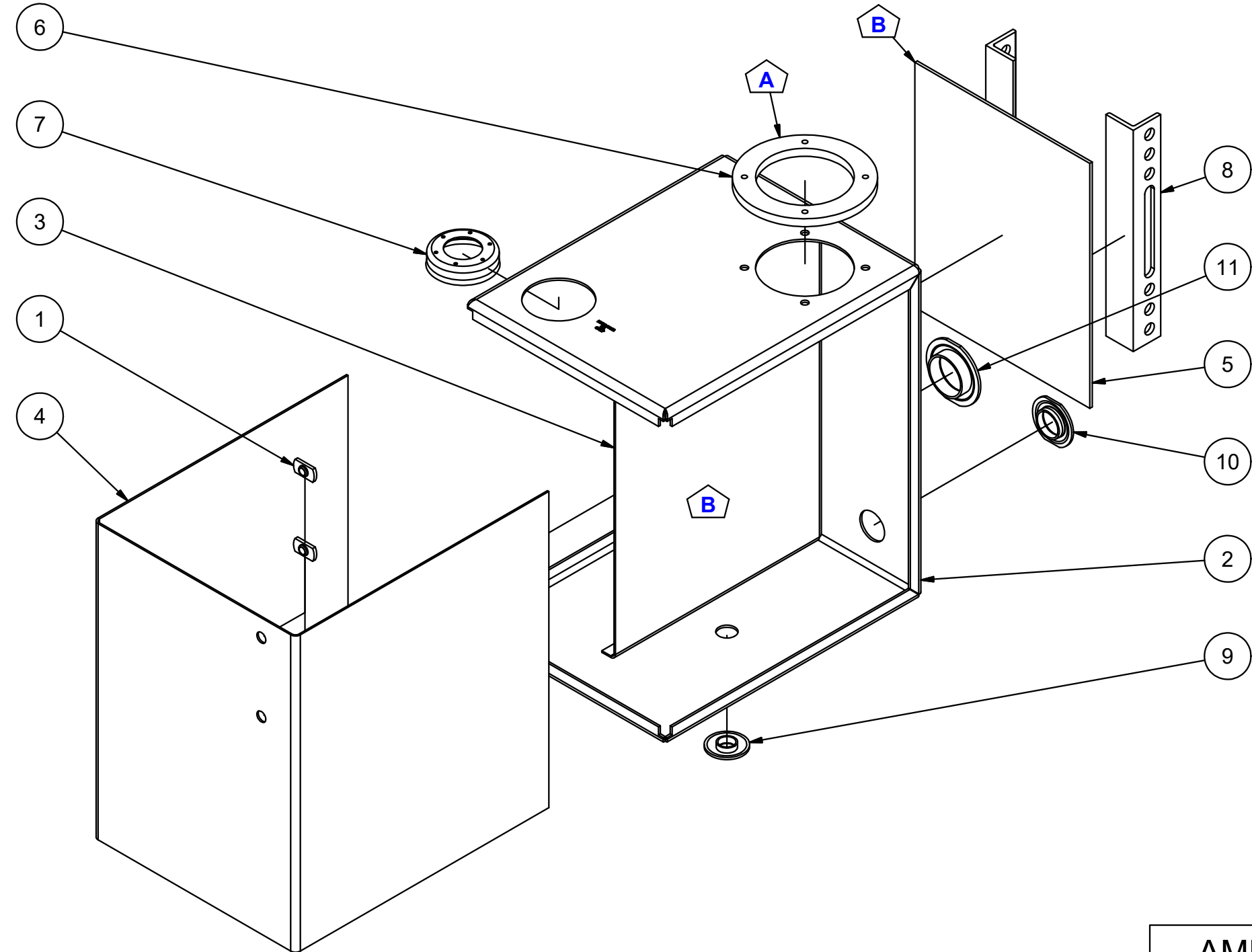

B

A

A

4

3

2

1

DATE	SYM.	DESCRIPTION	BY
11-1-13	B	ADD SUPPORT PLATE; REV. BAFFLE	BPK
4-19-12	A	AFS-3-1250 REPLACES 0375-16-FWN's	BPK

REVISIONS

<b>AMERICAN MOBILE POWER</b> PH: (800) 634-8265 FAX: (765) 948-3403	DRAWING BY: BPKNIGHT	DESIGN FOR: AMP	FILE NAME: A325SL	
	COMPLETED: 4/30/2008		SHEET: 3 of 8	SHEET SIZE: B