

Parts List			
ITEM	QTY	PART NUMBER	DESCRIPTION
1	1	57XL-40	40 Micron FILL w/30 Mesh Stainless Strainer
2	1	APP0750-M	3/4" NPT MAG PLUG
3	1	APP1250	1 1/4" NPT SQUARE SOCKET PLUG
4	1	APP2000	2" NPT SQUARE SOCKET PLUG
5	1	N_A3150	NAM WELDMENT ~56.86 lbs
6	1	T-LLG-5	SIGHT/TEMP. GAUGE, 5"

NOTES:
 -POWDER COAT BLACK
 -APPLY RUST INHIBITOR INSIDE
 -PLUG ALL PORTS FOR SHIPMENT

STAMP SERIAL No. HERE

DATE	SYM.	DESCRIPTION	BY
9-13-18	E	ADDED S/N NOTE	BPK
8-2-17	D	REV HOLES FOR PLASMA	BPK
12-1-15	C	RETURNED FLANGES TO 1" DIM.	BPK
10-10-14	B	CHANGE FLANGE LENGTH ON BS	BPK
7-11-07	A	ADD "HYDRAULIC OIL ONLY" STAMP	BPK
1-31-07	N/A	FORMAT UPDATE	BPK

WT: ~58.77 lbs

AMERICAN MOBILE POWER PH: (800) 634-8265 FAX: (765) 948-3403	DRAWING BY: MRH	DESIGN FOR: AMP	FILE NAME: A3150	
	COMPLETED: 1/10/2001		SHEET: 1 of 7	SHEET SIZE: B

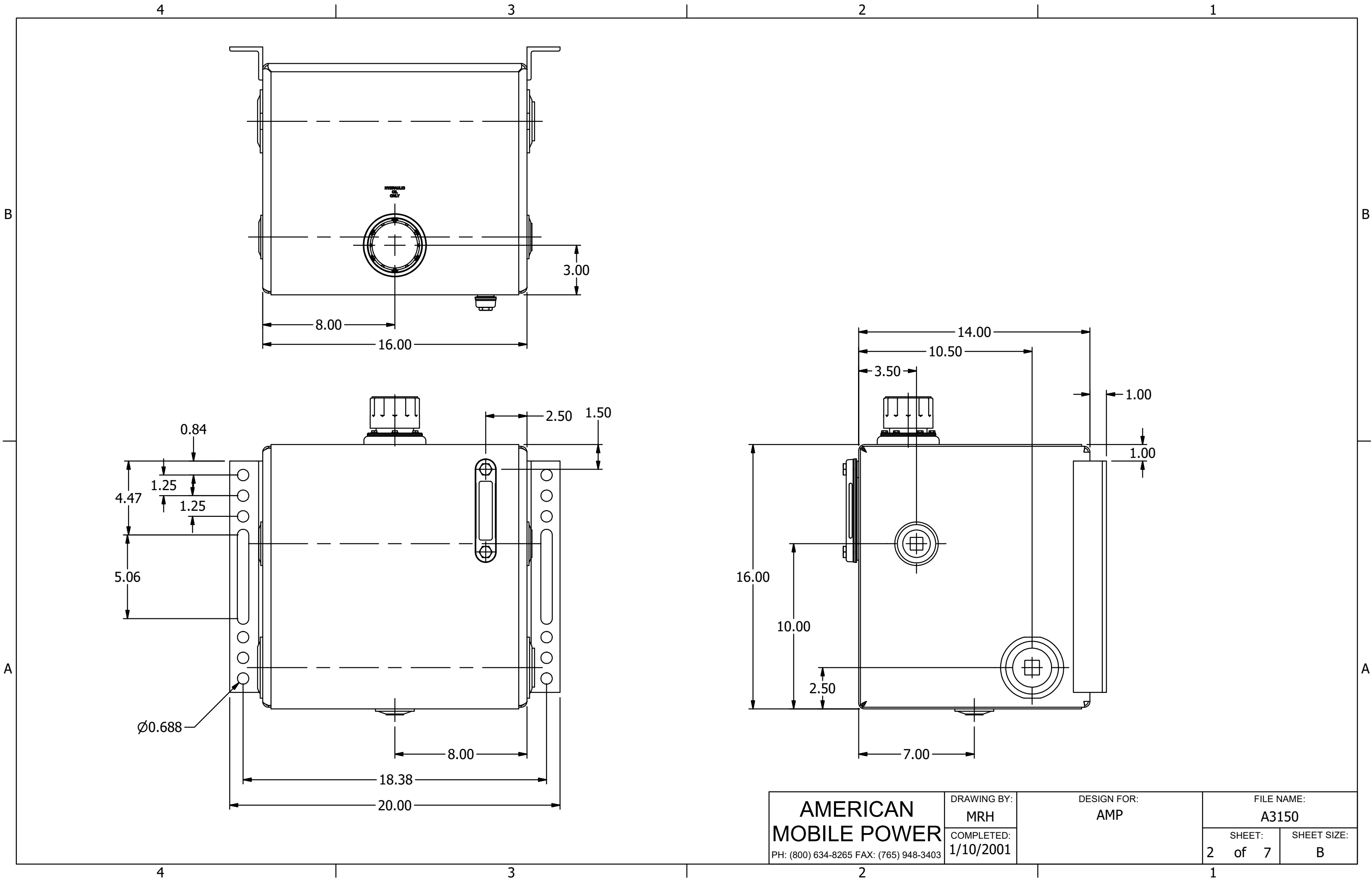

AMERICAN MOBILE POWER <small>PH: (800) 634-8265 FAX: (765) 948-3403</small>	DRAWING BY: MRH	DESIGN FOR: AMP	FILE NAME: A3150	
	COMPLETED: 1/10/2001		SHEET: 2 of 7	SHEET SIZE: B

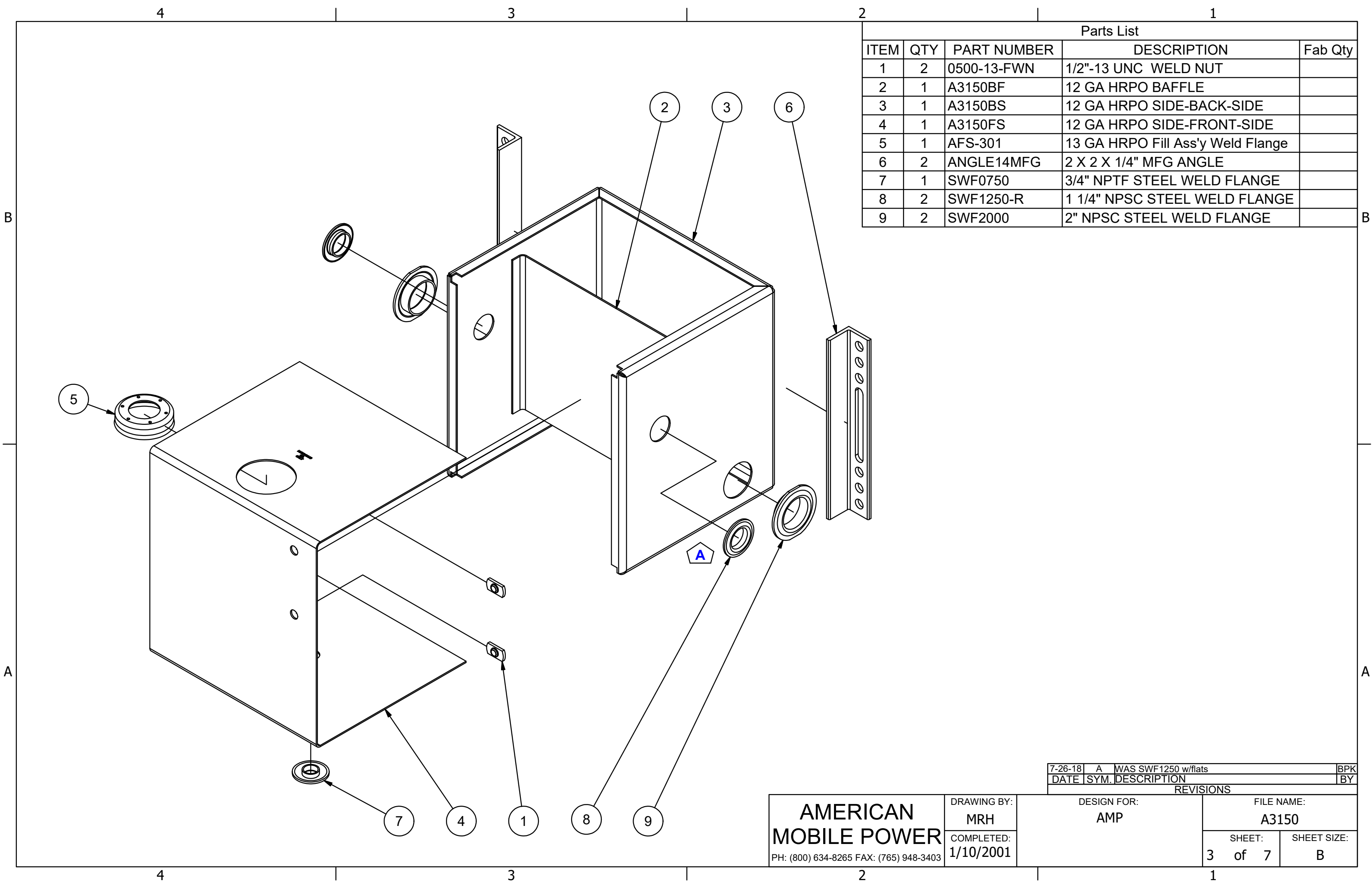

Parts List				
ITEM	QTY	PART NUMBER	DESCRIPTION	Fab Qty
1	2	0500-13-FWN	1/2"-13 UNC WELD NUT	
2	1	A3150BF	12 GA HRPO BAFFLE	
3	1	A3150BS	12 GA HRPO SIDE-BACK-SIDE	
4	1	A3150FS	12 GA HRPO SIDE-FRONT-SIDE	
5	1	AFS-301	13 GA HRPO Fill Ass'y Weld Flange	
6	2	ANGLE14MFG	2 X 2 X 1/4" MFG ANGLE	
7	1	SWF0750	3/4" NPTF STEEL WELD FLANGE	
8	2	SWF1250-R	1 1/4" NPSC STEEL WELD FLANGE	
9	2	SWF2000	2" NPSC STEEL WELD FLANGE	

DATE	SYM.	DESCRIPTION	BY
7-26-18	A	WAS SWF1250 w/flats	BPK

AMERICAN MOBILE POWER PH: (800) 634-8265 FAX: (765) 948-3403	DRAWING BY: MRH	DESIGN FOR: AMP	FILE NAME: A3150	
	COMPLETED: 1/10/2001	SHEET: 3 of 7		SHEET SIZE: B

4 3 2 1

B

A

A

4 3 2 1