

Parts List			
ITEM	QTY	PART NUMBER	DESCRIPTION
1	1	57XL-40	40 Micron FILL w/30 Mesh Stainless Strainer
2	1	ABA-138	3/8" NPT VENT
3	1	N_A3070-ST	NAM WELDMENT ~136.9 lbs
4	1	T-LLG-5	SIGHT/TEMP. GAUGE, 5"

AMP PARTS INCLUDE:
 -ABK-340-C OR ABK-340-S MOUNTING KIT

NOTES:
 -POWDER COAT BLACK
 -APPLY RUST INHIBITOR INSIDE
 -PLUG ALL PORTS FOR SHIPMENT

DATE	SYM.	DESCRIPTION	BY
4-9-15	C	SHEET LENGTH WAS 48.00	BPK
6-1-12	B	INCREASED OAL BY 2.50	BPK
6-7-11	A	UPDATE OFFSET DEPICTION	BPK

S/N ON HEAD

AMERICAN MOBILE POWER <small>PH: (800) 634-8265 FAX: (765) 948-3403</small>	DRAWING BY: BPKNIGHT	DESIGN FOR: AMERICAN MOBILE POWER	FILE NAME: A3070-ST	
	COMPLETED: 2/6/2007		SHEET: 1 of 8	SHEET SIZE: B

4

3

2

1

B

B

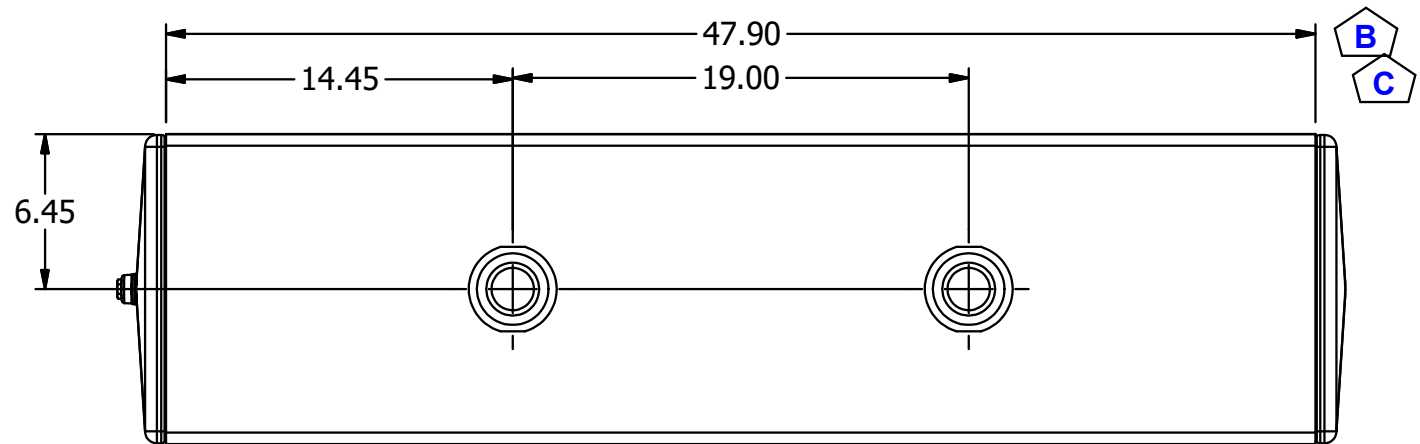
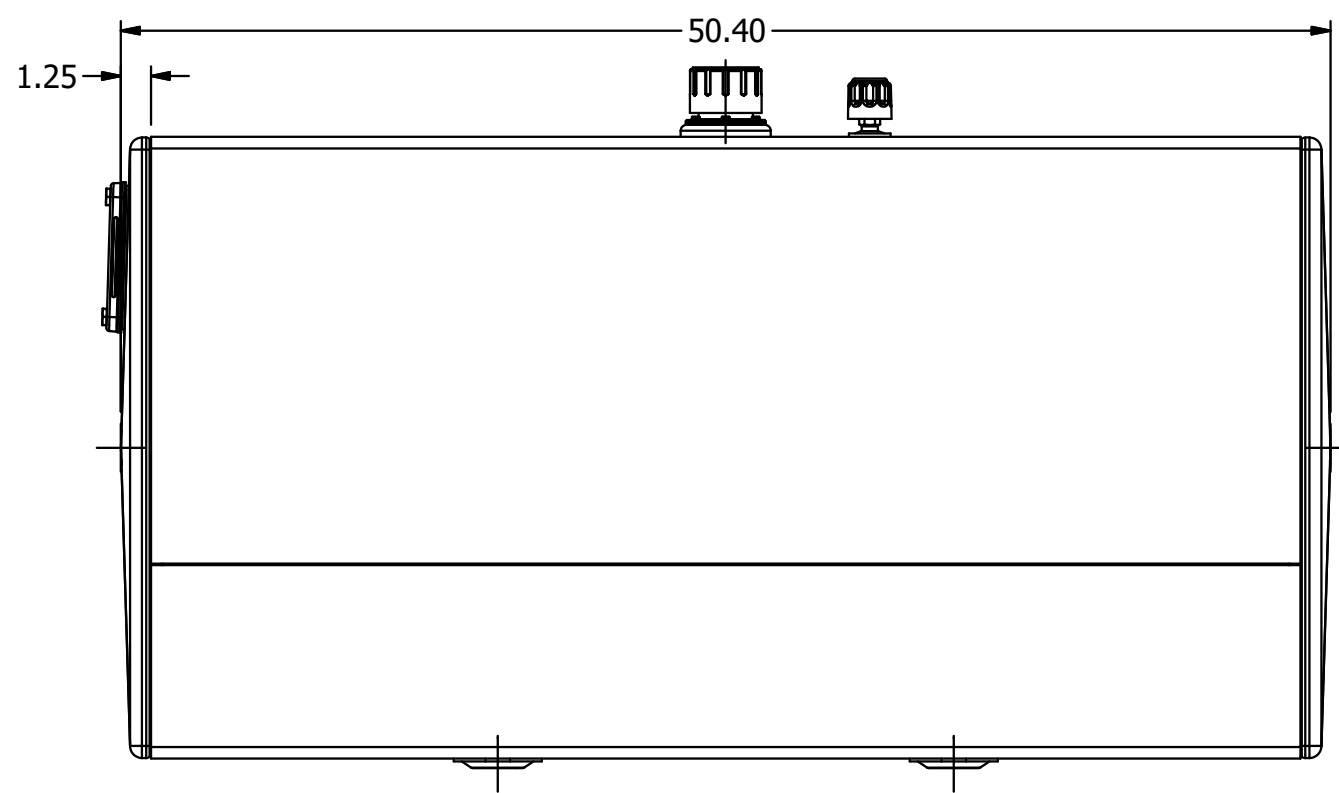
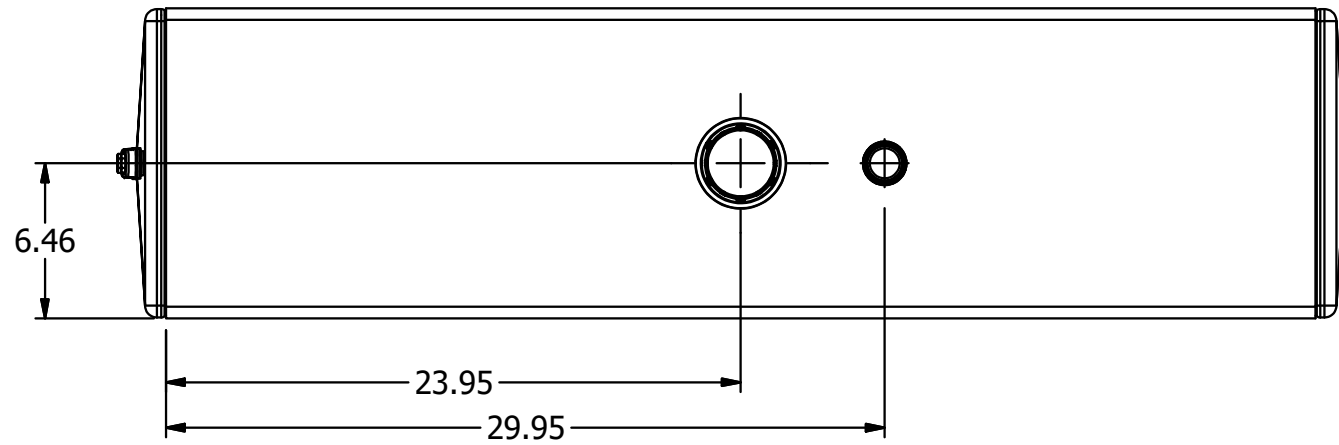
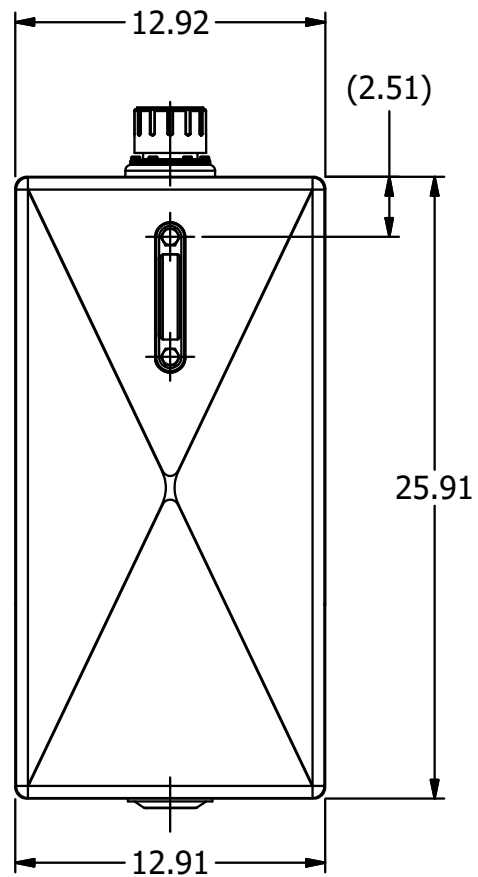

A

A

REVISIONS			
DATE	SYM.	DESCRIPTION	BY
4-9-15	C	SHEET LENGTH WAS 48.00	BPK
6-1-12	B	SHEET LENGTH WAS 45.50	BPK

AMERICAN MOBILE POWER PH: (800) 634-8265 FAX: (765) 948-3403	DRAWING BY: BPKNIGHT	DESIGN FOR: AMERICAN MOBILE POWER	FILE NAME: A3070-ST	
	COMPLETED: 2/6/2007		SHEET: 2 of 8	SHEET SIZE: B

4

3

2

1

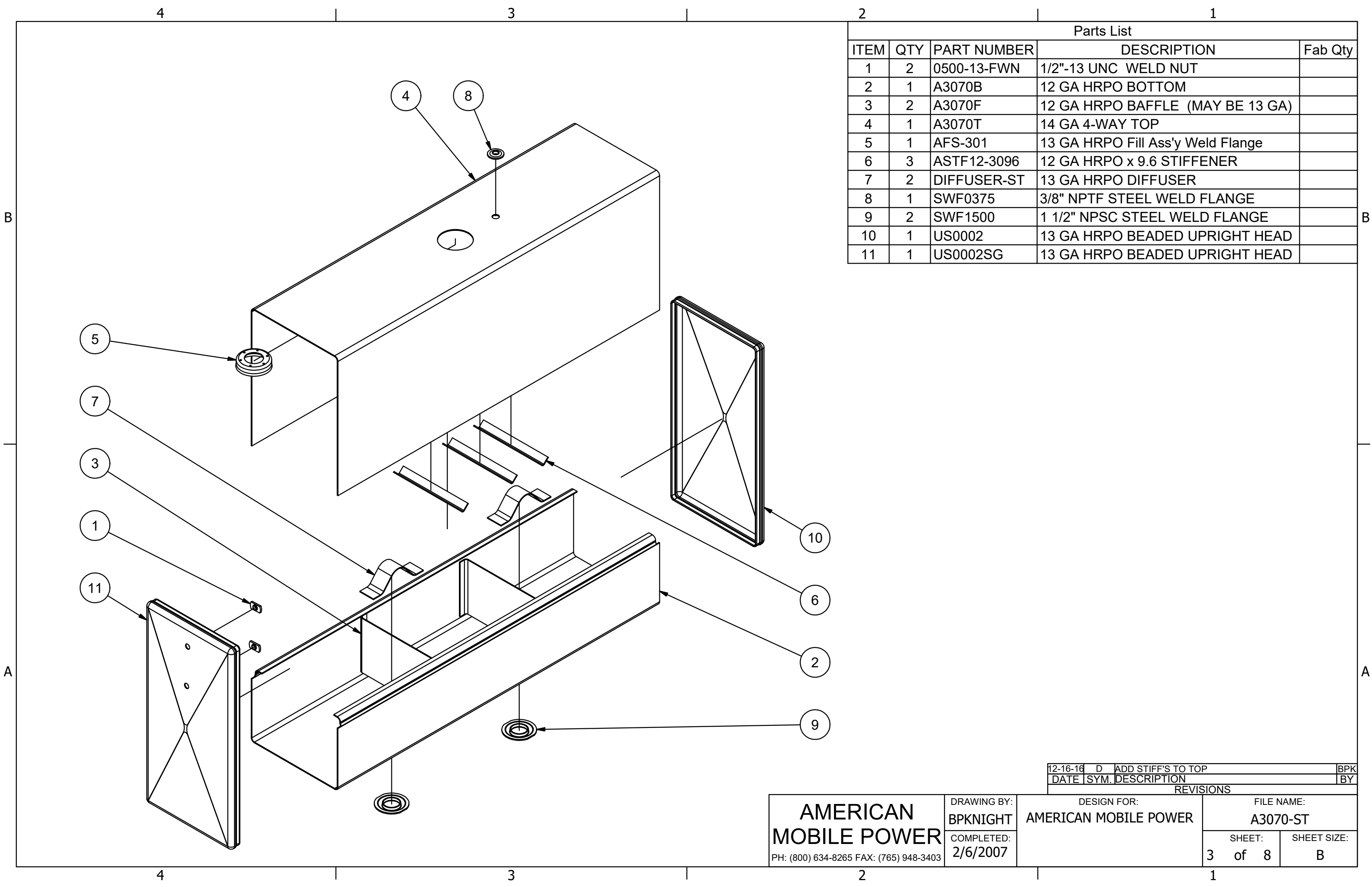

Parts List				
ITEM	QTY	PART NUMBER	DESCRIPTION	Fab Qty
1	2	0500-13-FWN	1/2"-13 UNC WELD NUT	
2	1	A3070B	12 GA HRPO BOTTOM	
3	2	A3070F	12 GA HRPO BAFFLE (MAY BE 13 GA)	
4	1	A3070T	14 GA 4-WAY TOP	
5	1	AFS-301	13 GA HRPO Fill Ass'y Weld Flange	
6	3	ASTF12-3096	12 GA HRPO x 9.6 STIFFENER	
7	2	DIFFUSER-ST	13 GA HRPO DIFFUSER	
8	1	SWF0375	3/8" NPTF STEEL WELD FLANGE	
9	2	SWF1500	1 1/2" NPSC STEEL WELD FLANGE	
10	1	US0002	13 GA HRPO BEADED UPRIGHT HEAD	
11	1	US0002SG	13 GA HRPO BEADED UPRIGHT HEAD	

12-16-16	D	ADD STIFF'S TO TOP	BPK
DATE	SYM.	DESCRIPTION	BY

REVISIONS

AMERICAN MOBILE POWER PH: (800) 634-8265 FAX: (765) 948-3403	DRAWING BY: BPKNIGHT	DESIGN FOR: AMERICAN MOBILE POWER	FILE NAME: A3070-ST	
	COMPLETED: 2/6/2007		SHEET: 3 of 8	SHEET SIZE: B