

Parts List			
ITEM	QTY	PART NUMBER	DESCRIPTION
1	1	57XL-40	40 Micron FILL w/30 Mesh Stainless Strainer
2	1	ABA-138	3/8" NPT VENT
3	1	AFC-507	FILTER PORT COVER 6.25 DIA. B.C.
4	1	APP0750-M	3/4" NPT MAG PLUG
5	1	LTF-32-32R5	2" x 2" NPT 100 MESH SUCTION STRAINER
6	1	N_A3070-2STRF	NAM WELDMENT ~146 1/2 lbs
7	1	T-LLG-5	SIGHT/TEMP. GAUGE, 5"

AMP PARTS INCLUDE:
 -ABK-340-C OR ABK-340-S MOUNTING KIT

NOTES:
 -POWDER COAT BLACK
 -APPLY RUST INHIBITOR INSIDE
 -PLUG ALL PORTS FOR SHIPMENT

C
 STAMP
 SERIAL No.
 HERE

DATE	SYM.	DESCRIPTION	BY
8-13-18	C	S/N WAS ON BITTOM OF TANK	BPK
4-9-15	B	LENGTH WAS 48.000	BPK
5-7-13	A	ADDED SUCTION STRAINER AS STD PART	BPK

AMERICAN MOBILE POWER PH: (800) 634-8265 FAX: (765) 948-3403	DRAWING BY: BPKNIGHT	DESIGN FOR: AMERICAN MOBILE POWER	FILE NAME: A3070-2STRF
	COMPLETED: 4/24/2013	SHEET: 1 of 8 SHEET SIZE: B	

4

3

2

1

B

B

A

A

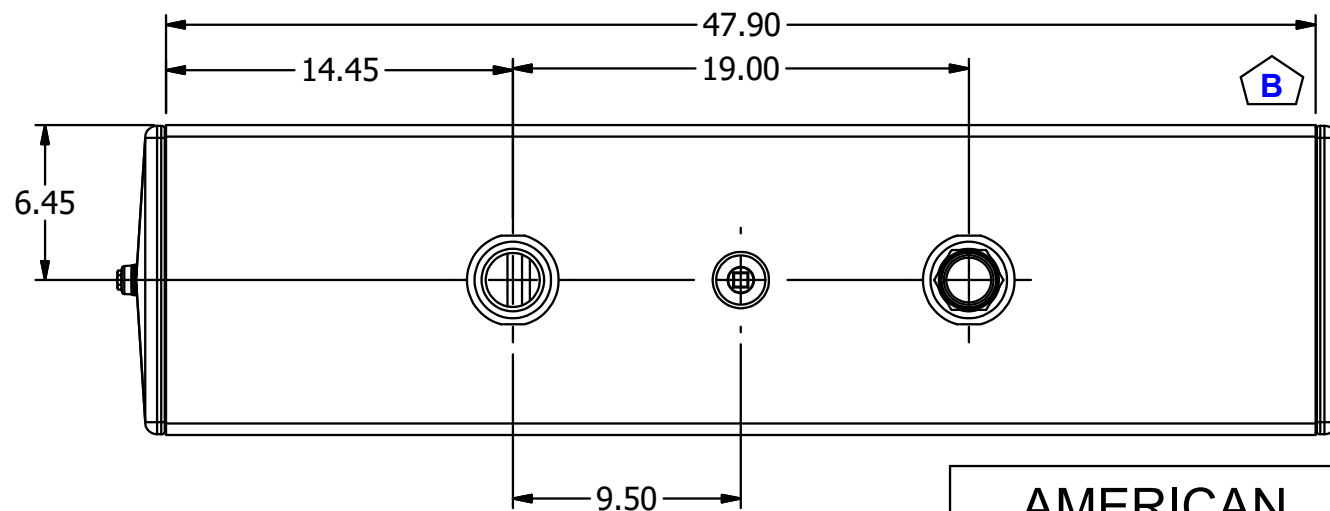
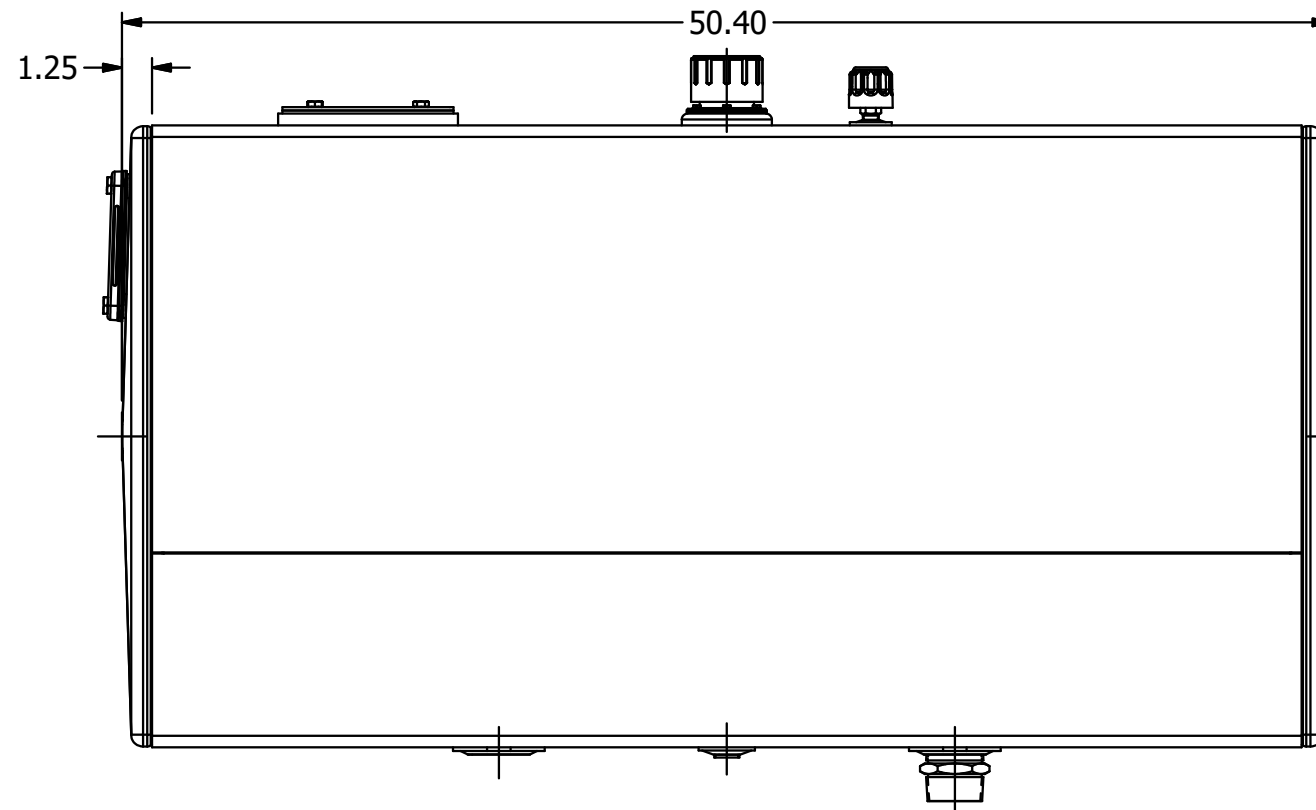
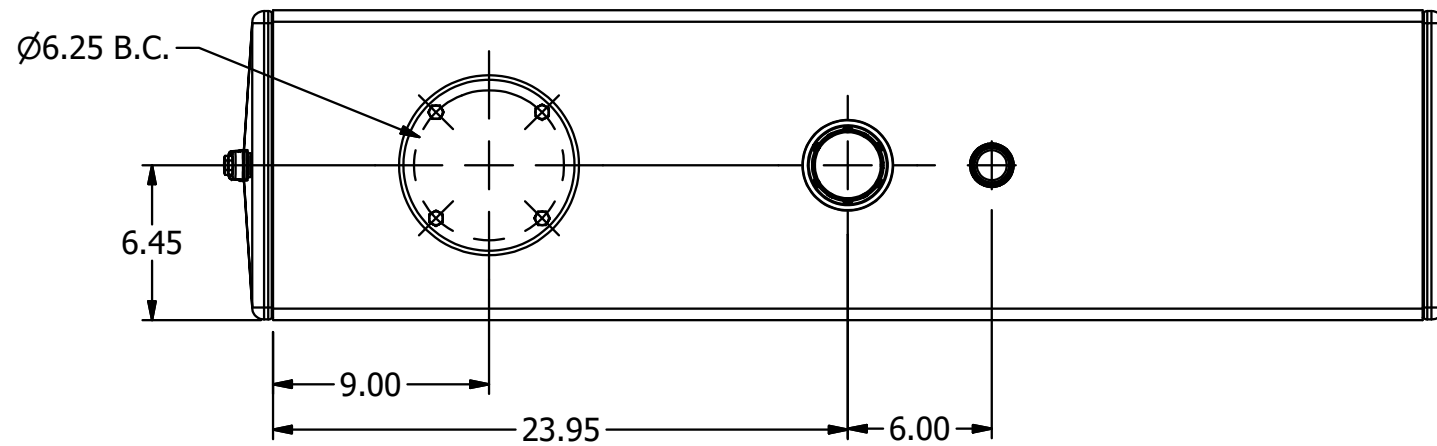
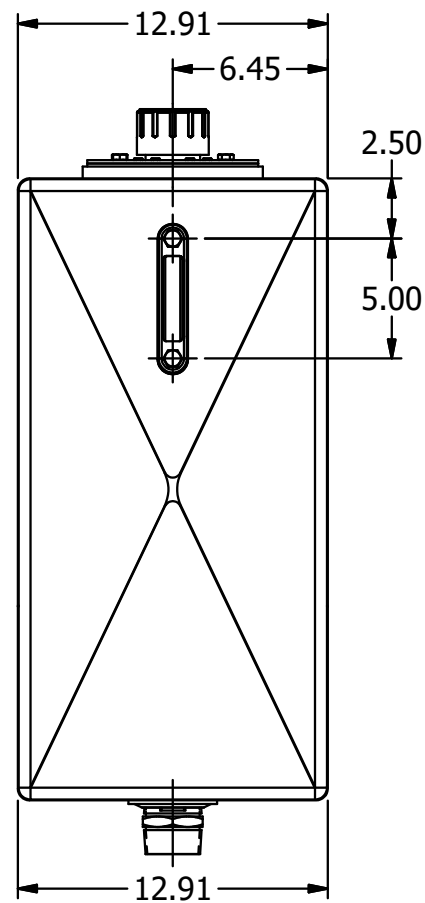

DATE	SYM.	DESCRIPTION	BY
4-9-15	B	LENGTH WAS 48.000	BPK

REVISIONS

AMERICAN MOBILE POWER PH: (800) 634-8265 FAX: (765) 948-3403	DRAWING BY: BPKNIGHT	DESIGN FOR: AMERICAN MOBILE POWER	FILE NAME: A3070-2STRF	
	COMPLETED: 4/24/2013		SHEET: 2 of 8	SHEET SIZE: B

4

3

2

1

4

3

2

1

Parts List

ITEM	QTY	PART NUMBER	DESCRIPTION	Fab Qty
1	2	0500-13-FWN	1/2"-13 UNC WELD NUT	
2	1	A3070-2STRFB	12 GA HRPO BOTTOM	
3	1	A3070-2STRFST	12 GA HRPO STIFFENER	
4	1	A3070-2STRFT	12 GA HRPO TOP	
5	2	A3070F	12 GA HRPO BAFFLE (MAY BE 13 GA)	
6	1	AFF-3-1250	.50 x 7.5 O.D. HRPO Filter Flange	
7	1	AFS-301	13 GA HRPO Fill Ass'y Weld Flange	
8	1	SWF0375	3/8" NPTF STEEL WELD FLANGE	
9	1	SWF0750	3/4" NPTF STEEL WELD FLANGE	
10	2	SWF2000	2" NPSC STEEL WELD FLANGE	
11	1	US0002	13 GA HRPO BEADED UPRIGHT HEAD	
12	1	US0002SG	13 GA HRPO BEADED UPRIGHT HEAD	

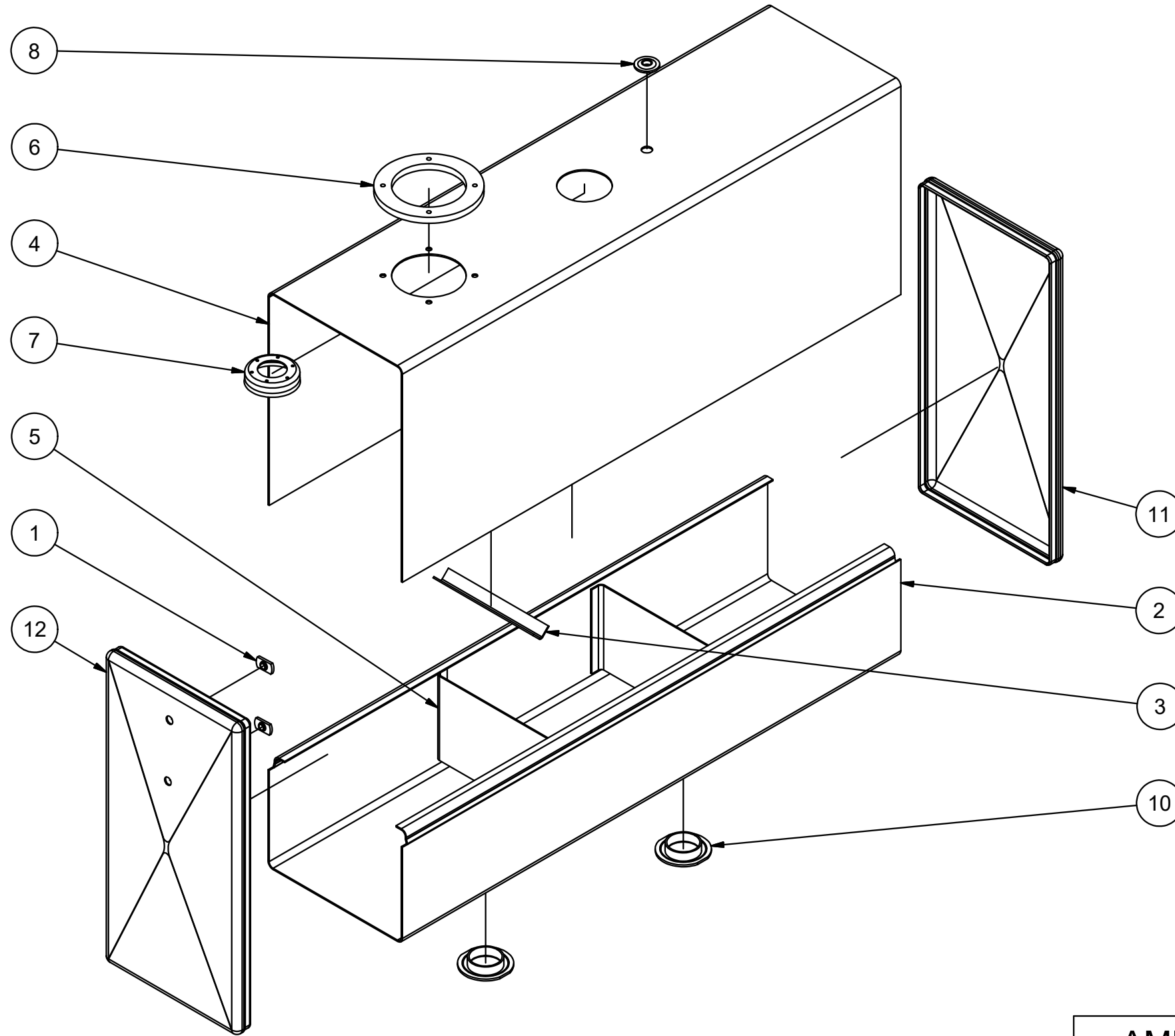

B

B

A

A

4

3

2

1

AMERICAN MOBILE POWER <small>PH: (800) 634-8265 FAX: (765) 948-3403</small>	DRAWING BY: BPKNIGHT	DESIGN FOR: AMERICAN MOBILE POWER	FILE NAME: A3070-2STRF	
	COMPLETED: 4/24/2013		SHEET: 3 of 8	SHEET SIZE: B