

4

3

2

1

Parts List

ITEM	QTY	PART NUMBER	DESCRIPTION
1	1	57XL-40	40 Micron FILL w/30 Mesh Stainless Strainer
2	1	ABA-138	3/8" NPT VENT
3	1	N_A3000-ST	NAM WELDMENT ~122.79 lbs
4	1	T-LLG-5	SIGHT/TEMP. GAUGE, 5"

AMP PARTS INCLUDE:
 -ASK-200 MOUNTING KIT

NOTES:
 -POWDER COAT BLACK
 -APPLY RUST INHIBITOR INSIDE
 -PLUG ALL PORTS FOR SHIPMENT

B

B

A

A

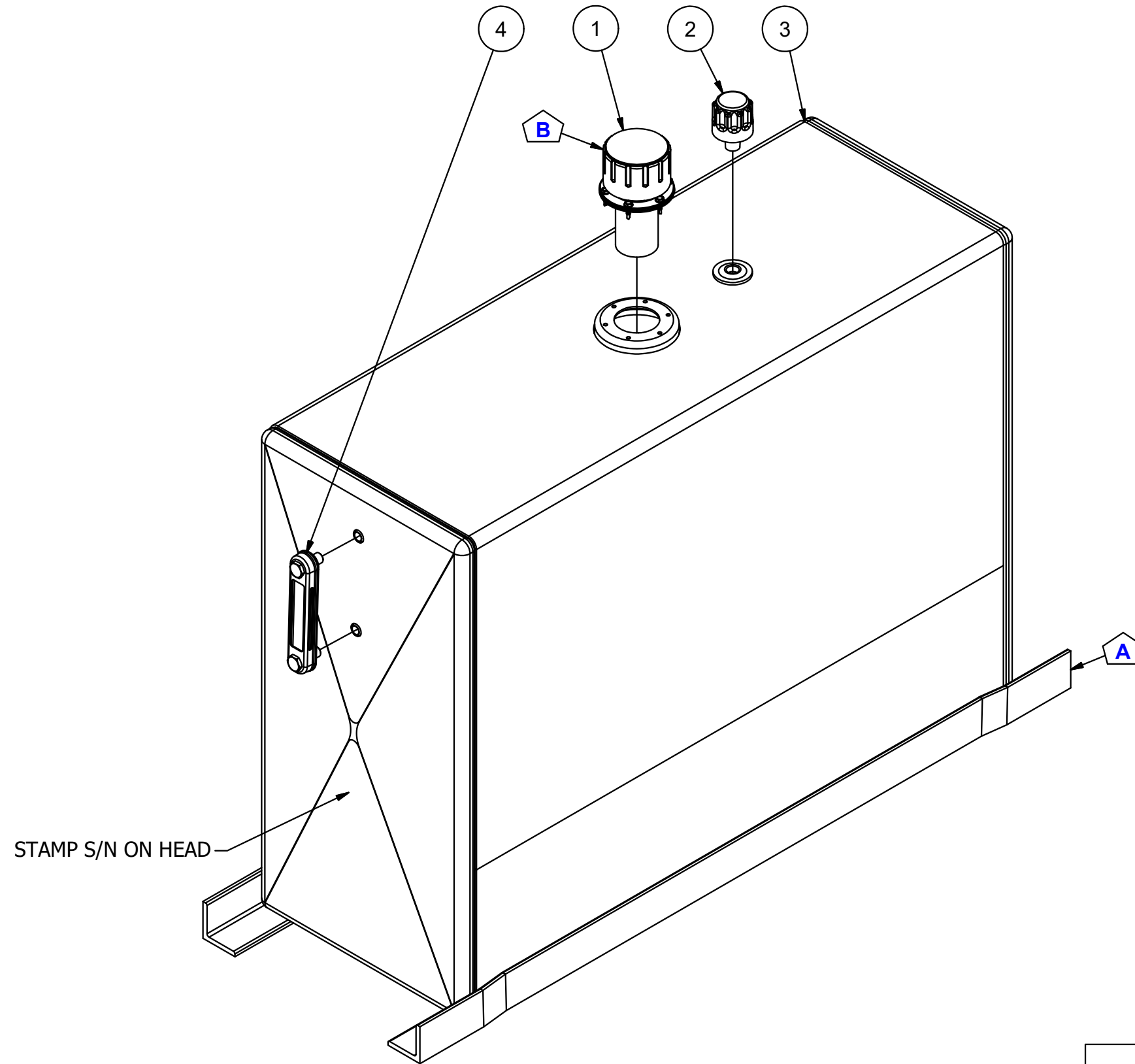

DATE	SYM.	DESCRIPTION	BY
9-17-18	N/A	S/N WAS ON BOTTOM OF ANGLE	BPK
3-30-16	B	WAS 57XL-40N	BPK
7-16-10	A	UPDATE MODEL -SHOW OFFSET ANGLES	BPK

AMERICAN MOBILE POWER PH: (800) 634-8265 FAX: (765) 948-3403	DRAWING BY: BPKNIGHT	DESIGN FOR: AMERICAN MOBILE POWER	FILE NAME: A3000-ST
	COMPLETED: 2/6/2007		SHEET: 1 of 8
			SHEET SIZE: B

4

3

2

1

4

3

2

1

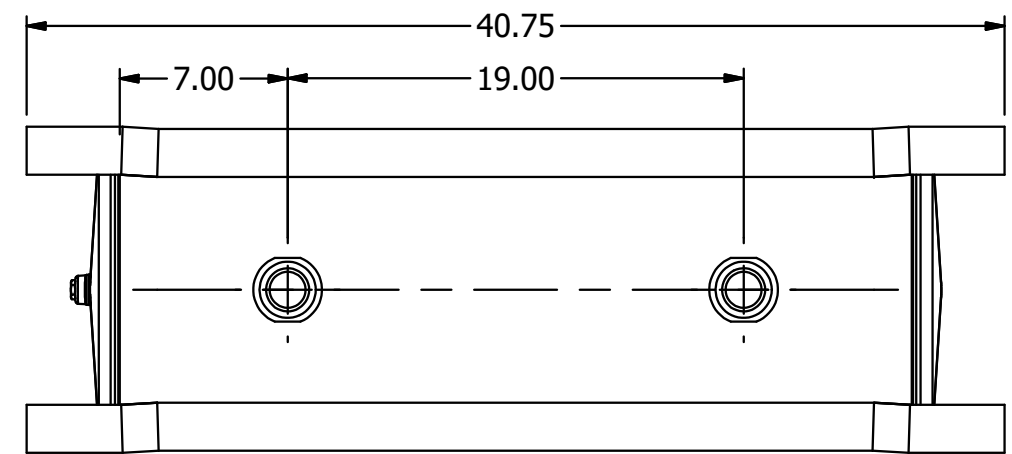
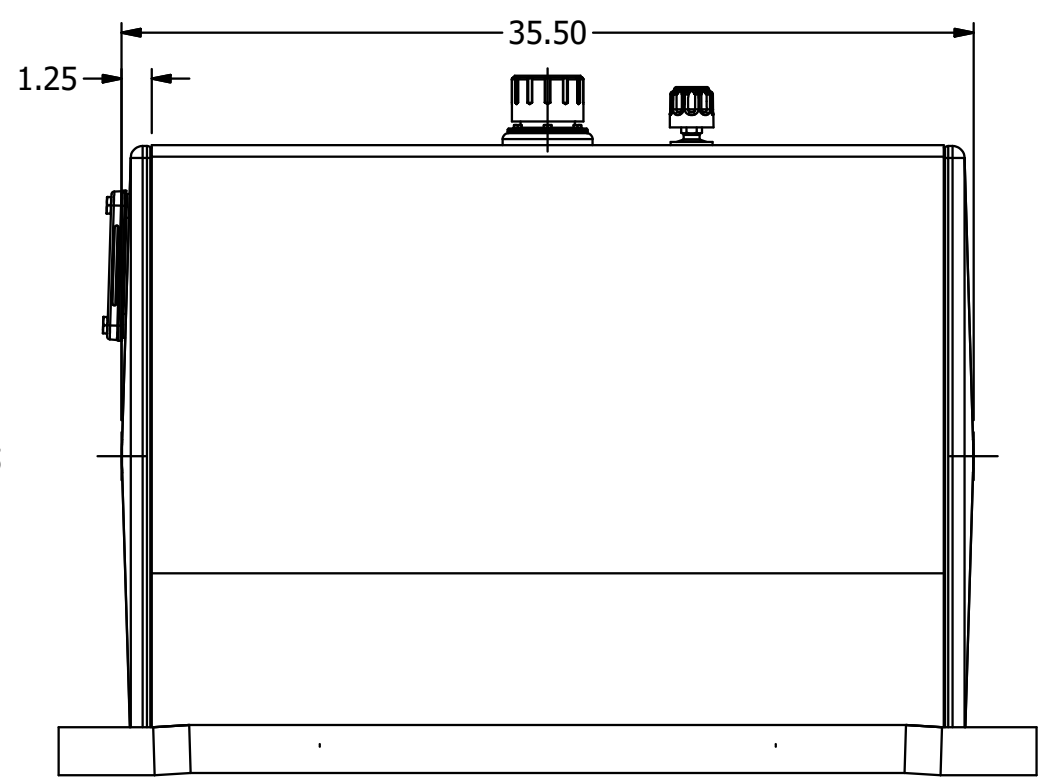
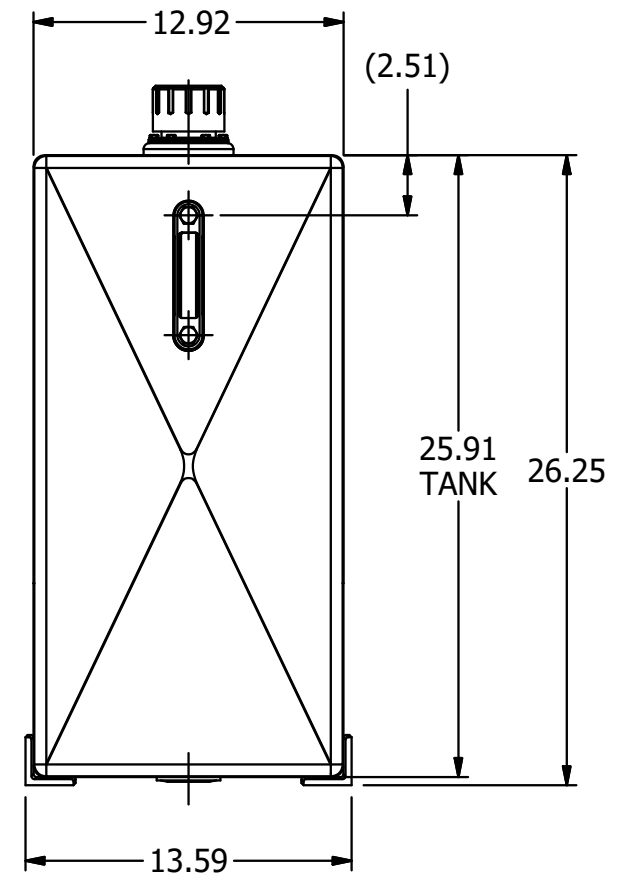
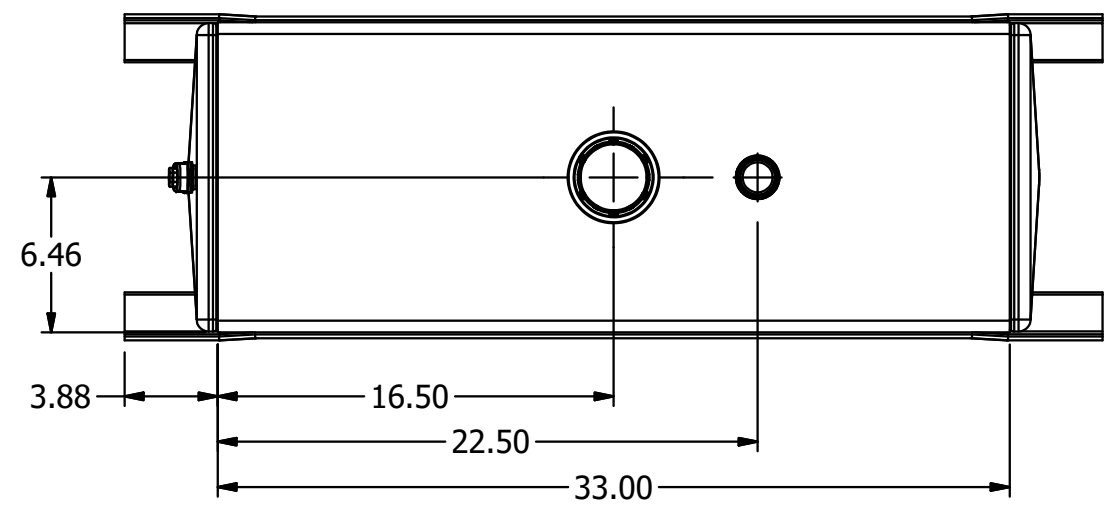

B

B

A

A

AMERICAN MOBILE POWER PH: (800) 634-8265 FAX: (765) 948-3403	DRAWING BY: BPKNIGHT	DESIGN FOR: AMERICAN MOBILE POWER	FILE NAME: A3000-ST	
	COMPLETED: 2/6/2007		SHEET: 2 of 8	SHEET SIZE: B

4

3

2

1

