

4

3

2

1

Parts List

ITEM	QTY	PART NUMBER	DESCRIPTION
1	1	APP0125	1/8" NPT PLUG
2	1	ASV-0500	1/2" NPT DIESEL ANTI-SPILL VENT
3	1	BCV-0500	1/2" NPT - 1/8" NPT Brass/Steel Ball Check Valve
4	1	FGA-2200	ROCHESTER 10" RADIUS FUEL GAUGE
5	1	FNC-2000	2" NON-VENTED DIESEL FILL CAP (600198)
6	1	MA-1_R11	USA STICKER
7	1	N_AR8575	NAM WELDMENT ~40 lbs
8	2	PRT-2400	PICK UP TUBE, STEEL, 24" REEFER
9	1	REEFER TAG_1	MANUFACTURING DATA TAG

* OPTIONAL AMP PARTS:
 -RMK-824-S MOUNTING KIT

NOTE:
 -PLUG ALL PORTS FOR SHIPMENT

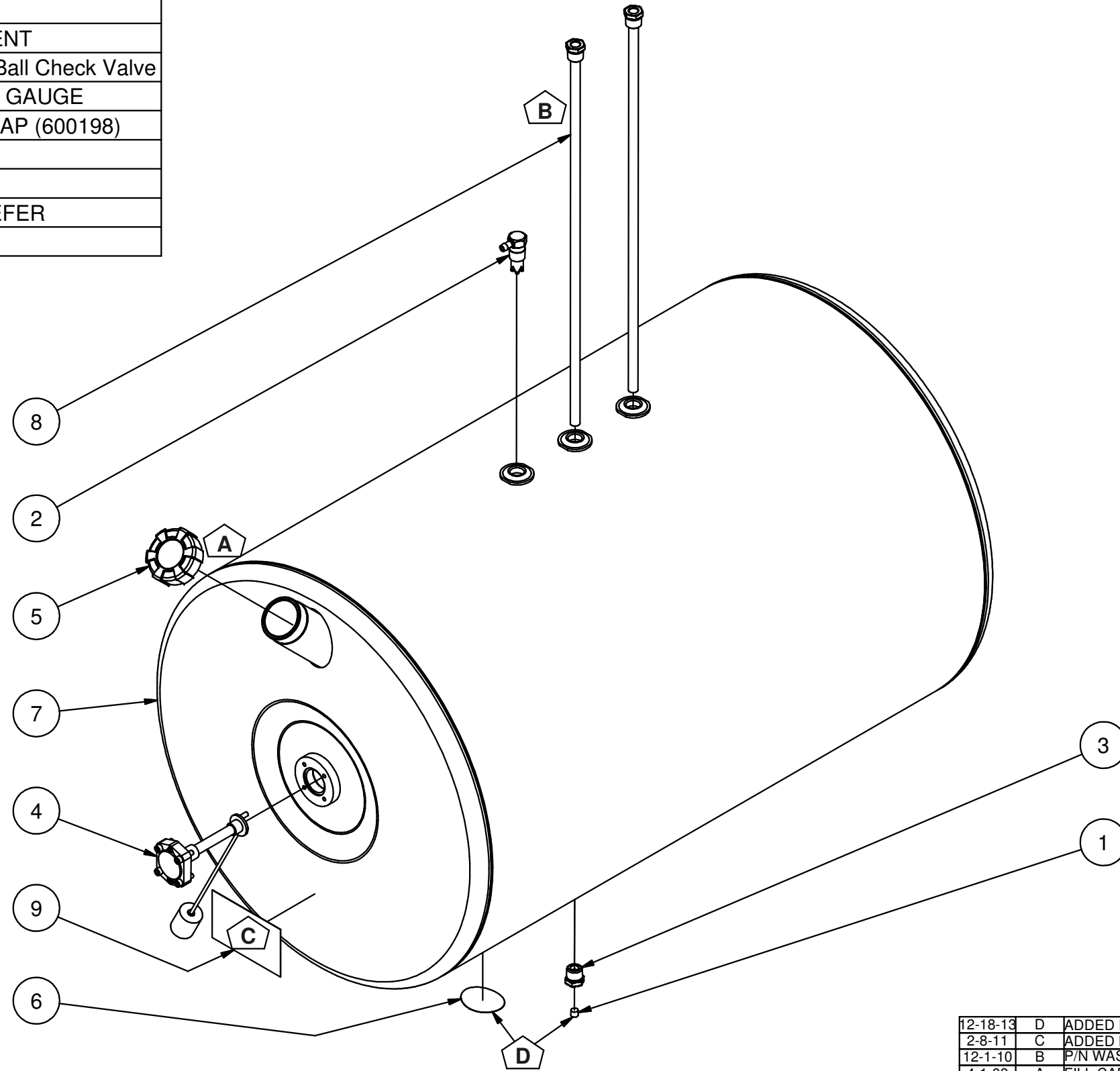

DATE	SYM.	DESCRIPTION	BY
12-18-13	D	ADDED PLUG AND STICKER TO MODEL	BPK
2-8-11	C	ADDED MFG TAG	BPK
12-1-10	B	P/N WAS 24_DROP_TUBE	BPK
4-1-08	A	FILL CAP WAS #600133	BPK

AMERICAN MOBILE POWER PH: (800) 634-8265 FAX: (765) 948-3403	DRAWING BY: BPKNIGHT	DESIGN FOR: AMP	FILE NAME: AR8575	
	COMPLETED: 8/23/2005		SHEET: 1 of 5	SHEET SIZE: B

4

3

2

1

A

A

B

B

4

3

2

1

B

B

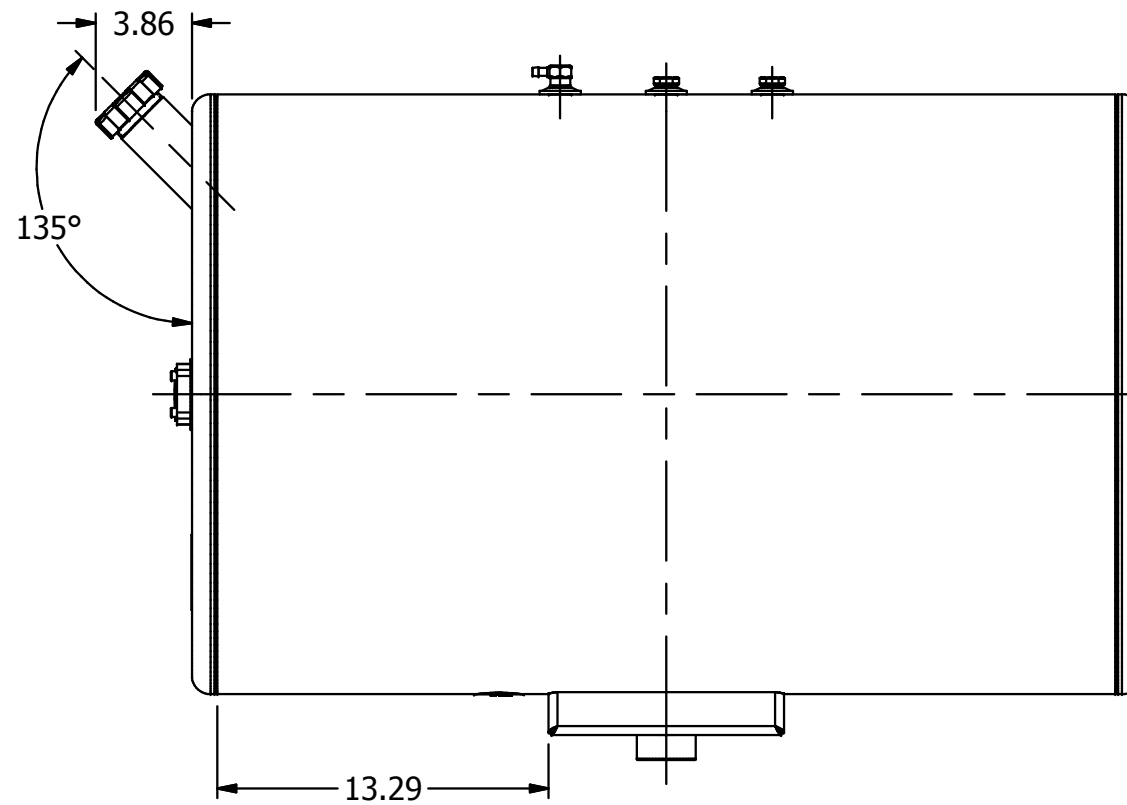
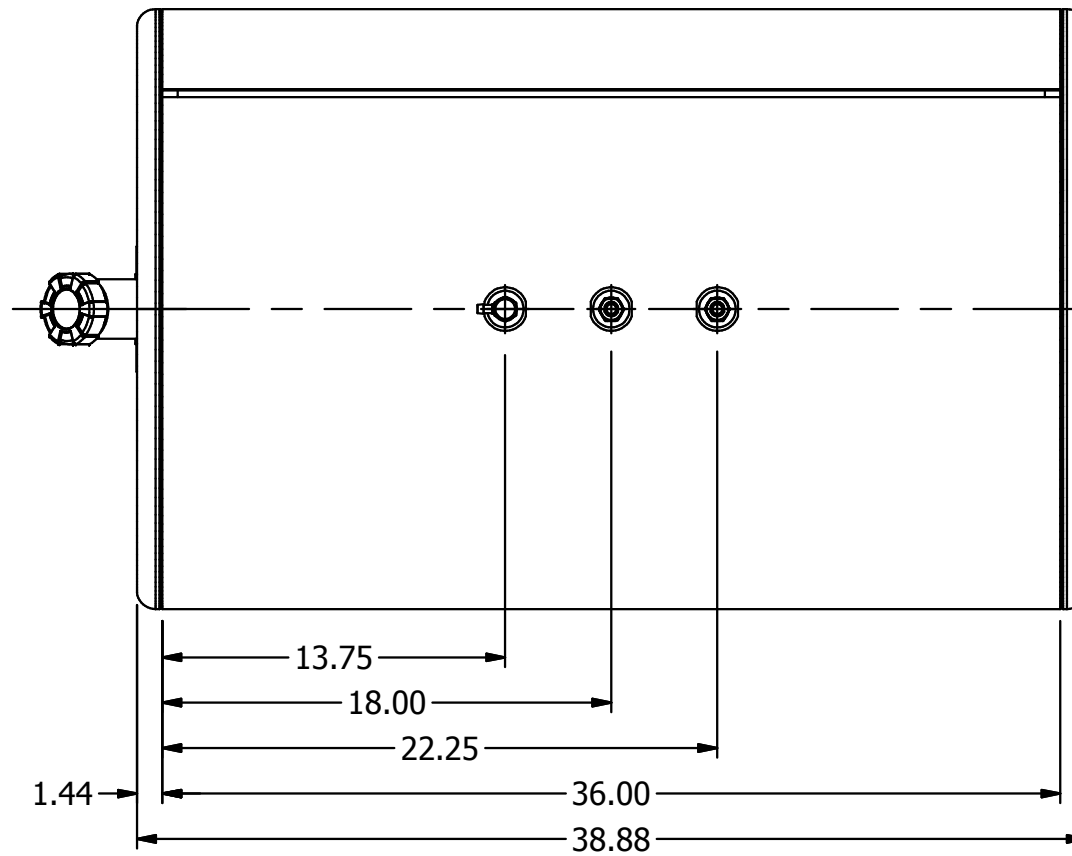
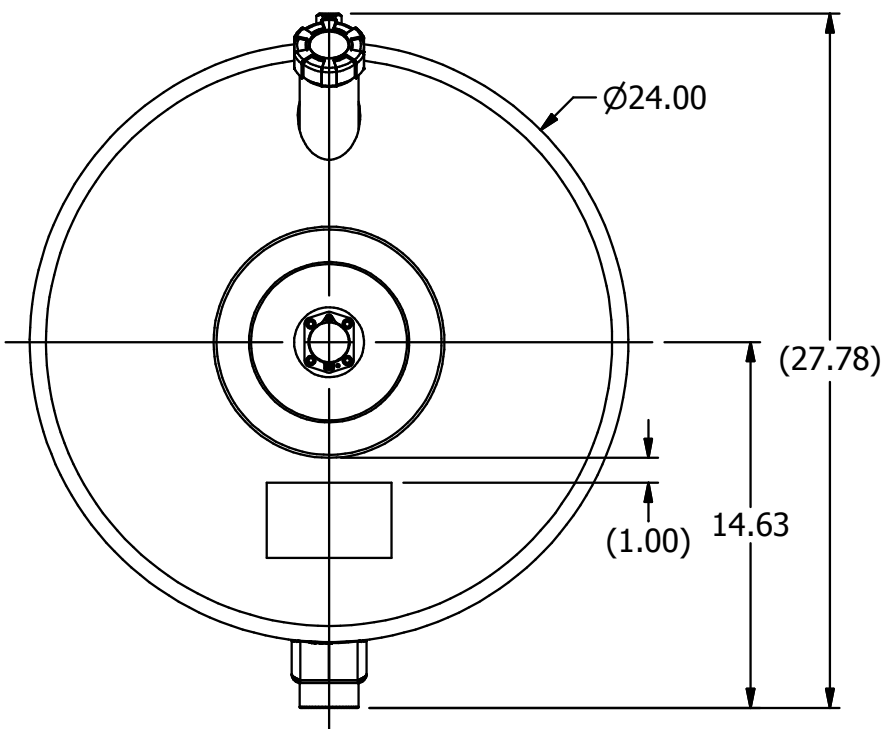

A

A

4

3

2

1

AMERICAN MOBILE POWER PH: (800) 634-8265 FAX: (765) 948-3403	DRAWING BY: BPKNIGHT	DESIGN FOR: AMP	FILE NAME: AR8575	
	COMPLETED: 8/23/2005		SHEET: 2 of 5	SHEET SIZE: B

4

3

2

1

Parts List

ITEM	QTY	PART NUMBER	DESCRIPTION	Fab Qty
1	1	AGF-8175	ALUMINUM GAUGE MOUNTING RING	
2	1	AR8575WS	.100 MILL ALUMINUM WRAP SHEET	
3	4	AWF0500	1/2" NPTF 6061-T6 WELD FLANGE	
4	1	RA0000SB	.100 5052-H32 Al SUMP BOX	
5	1	RA0000SR	2" SCH 40 x 1 ALUMINUM SUMP RING	
6	1	RA0008FL	.100 MILL ALUM 24" REEFER FILL HEAD	
7	1	RA2000FN	2" SCH 80 x 5 ALUMINUM FILL NECK	
8	1	SA0000NS	24 IN .100 MILL ALUMINUM HEAD	

B

B

A

A

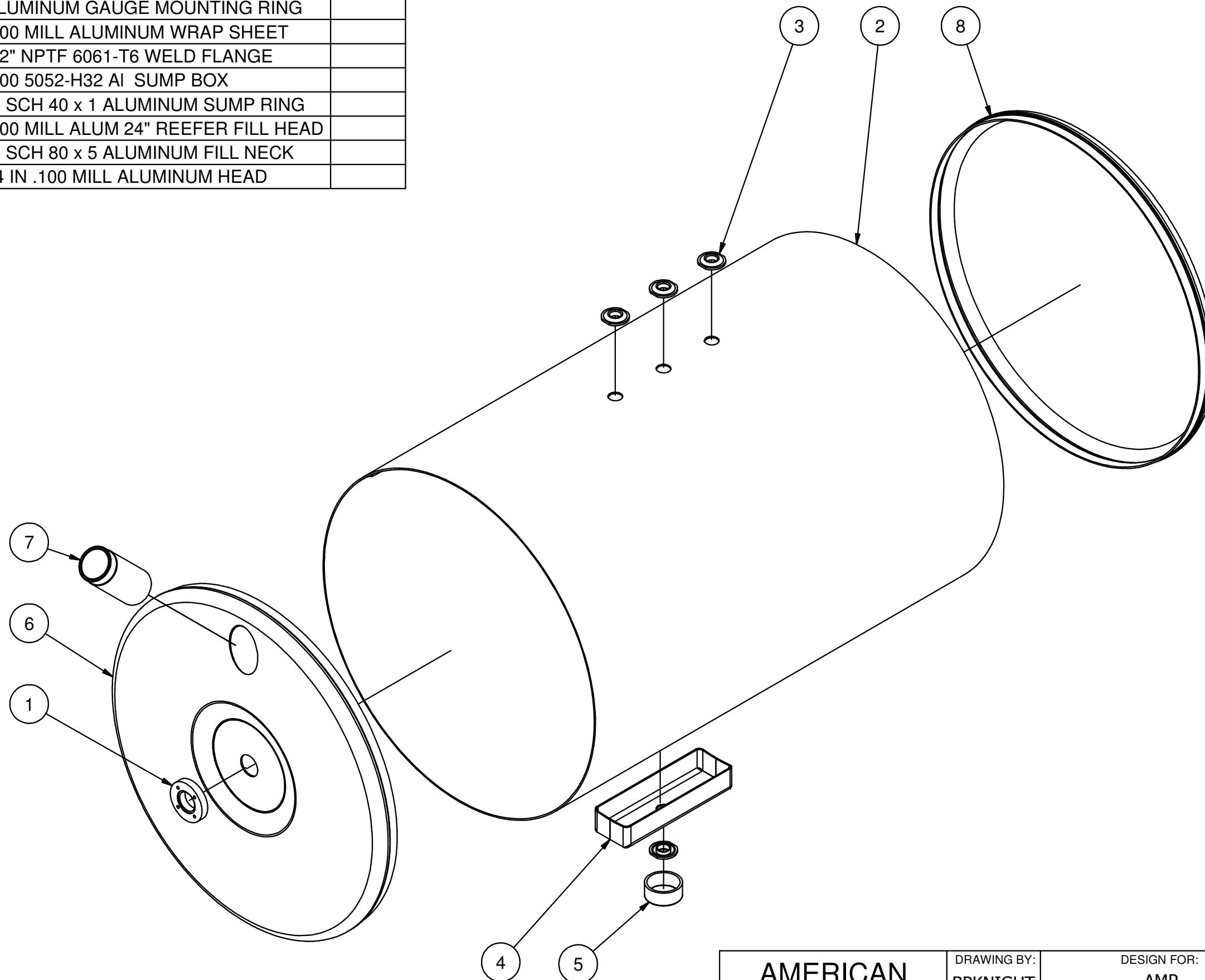

AMERICAN MOBILE POWER <small>PH: (800) 634-8265 FAX: (765) 948-3403</small>	DRAWING BY: BPKNIGHT	DESIGN FOR: AMP	FILE NAME: AR8575	
	COMPLETED: 8/23/2005		SHEET: 3 of 5	SHEET SIZE: B

4

3

2

1