

4

3

2

1

Parts List

ITEM	QTY	PART NUMBER	DESCRIPTION
1	1	0375-16-FWN	3/8-16 WELD NUT
2	1	13109	3/8-16 UNC x 1.5 Hex Cap Screw
3	1	17W08812	WASHER Flat .880x.375x.125 NYLON
4	1	APC-160-C-MS	12 GA HRPO CLAMP
5	1	APC-160-G	.25 NEOPRENE RUBBER GASKET
6	1	APC-160-T-MS	12 GA HRPO TOP

B

B

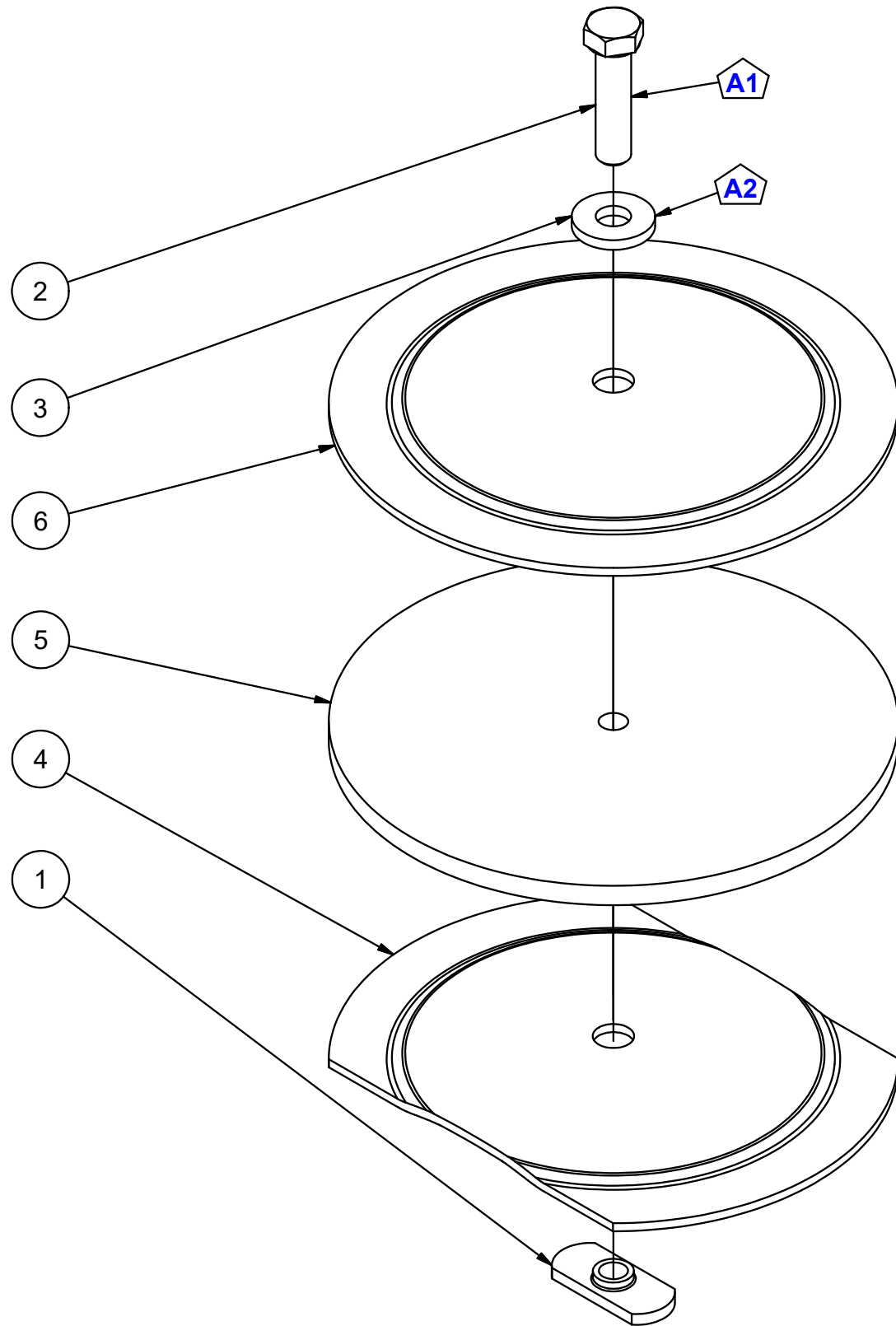

NOTES:  
 -POWDER COAT BLACK  
 -REMOVE BURRS & SHARP EDGES

A

A

4

3

2

1

DATE	SYM.	DESCRIPTION	BY
8-7-18	A	(1) WAS 1-1/4 LONG; 2) WAS 0375-SSBW	BPK

<b>AMERICAN MOBILE POWER</b> PH: (800) 634-8265 FAX: (765) 948-3403	DRAWING BY: bknight	DESIGN FOR: AMP	FILE NAME: APC-160-C	
	COMPLETED: 4/3/2006		SHEET: 1 of 5	SHEET SIZE: B

REVISIONS

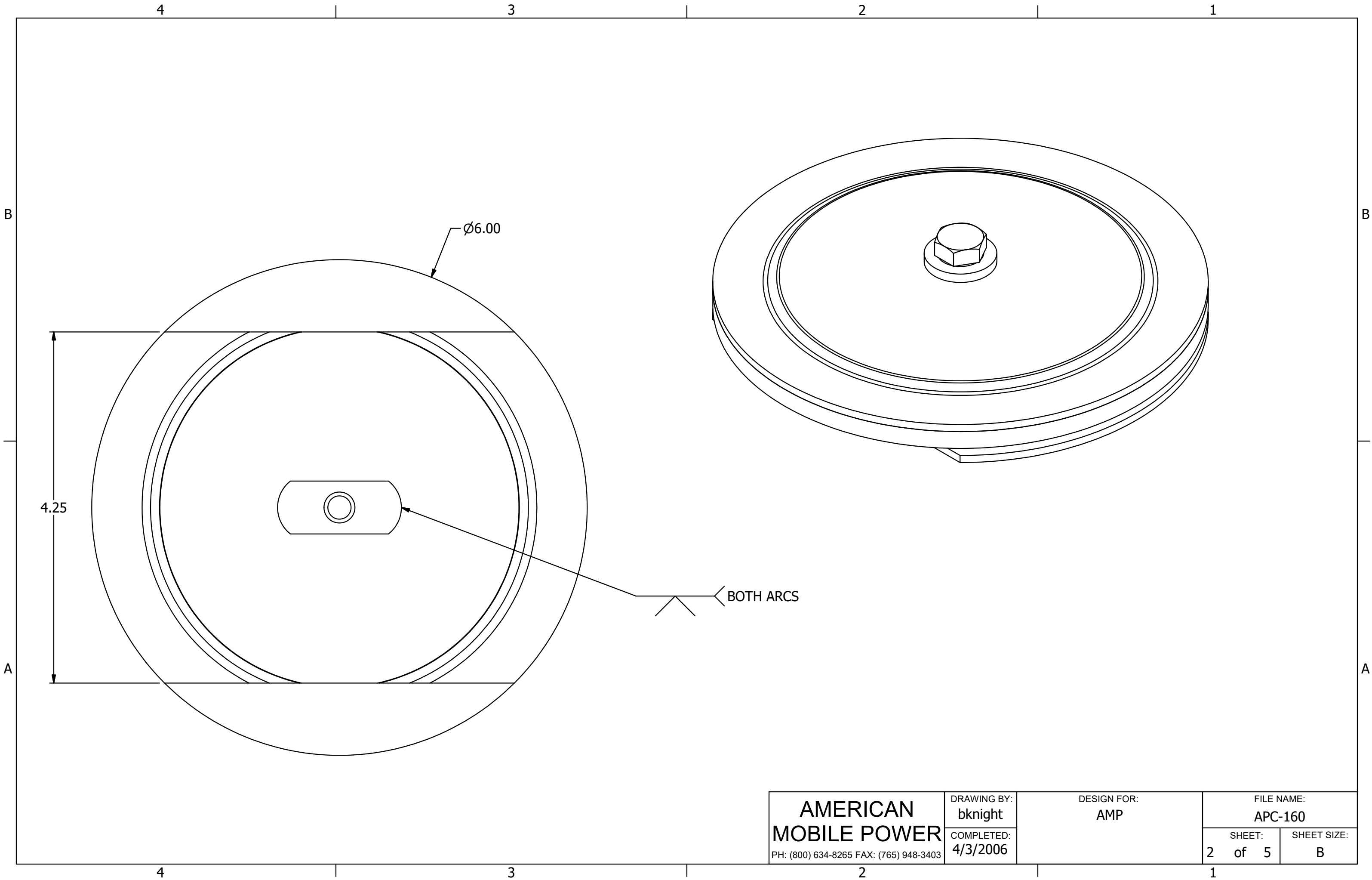

<b>AMERICAN MOBILE POWER</b> PH: (800) 634-8265 FAX: (765) 948-3403	DRAWING BY: bknight	DESIGN FOR: AMP	FILE NAME: APC-160	
	COMPLETED: 4/3/2006		SHEET: 2 of 5	SHEET SIZE: B