

4

3

2

1

Parts List

ITEM	QTY	PART NUMBER	VENDOR	DESCRIPTION
1	1	AFS-301	A & M TOOL	13 GA HRPO Fill Ass'y Weld Flange

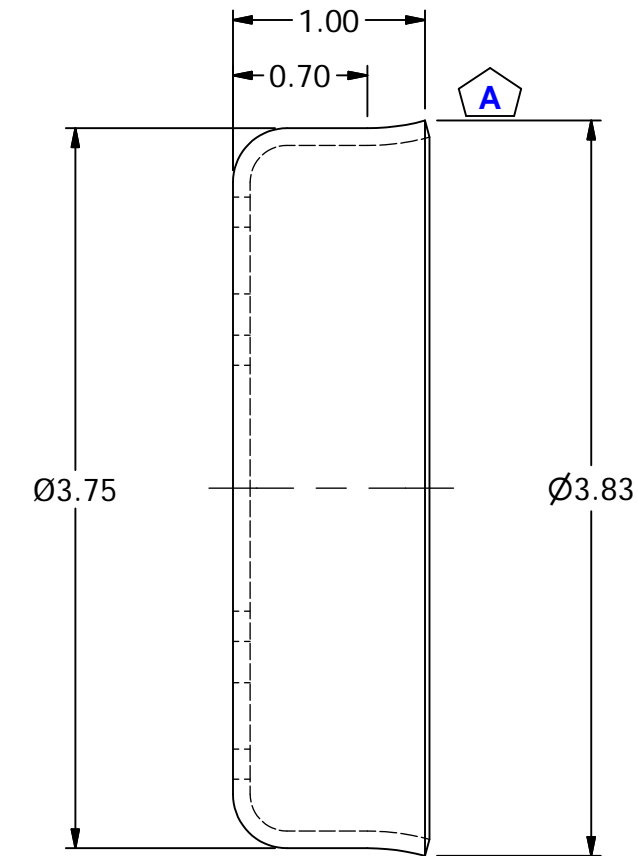
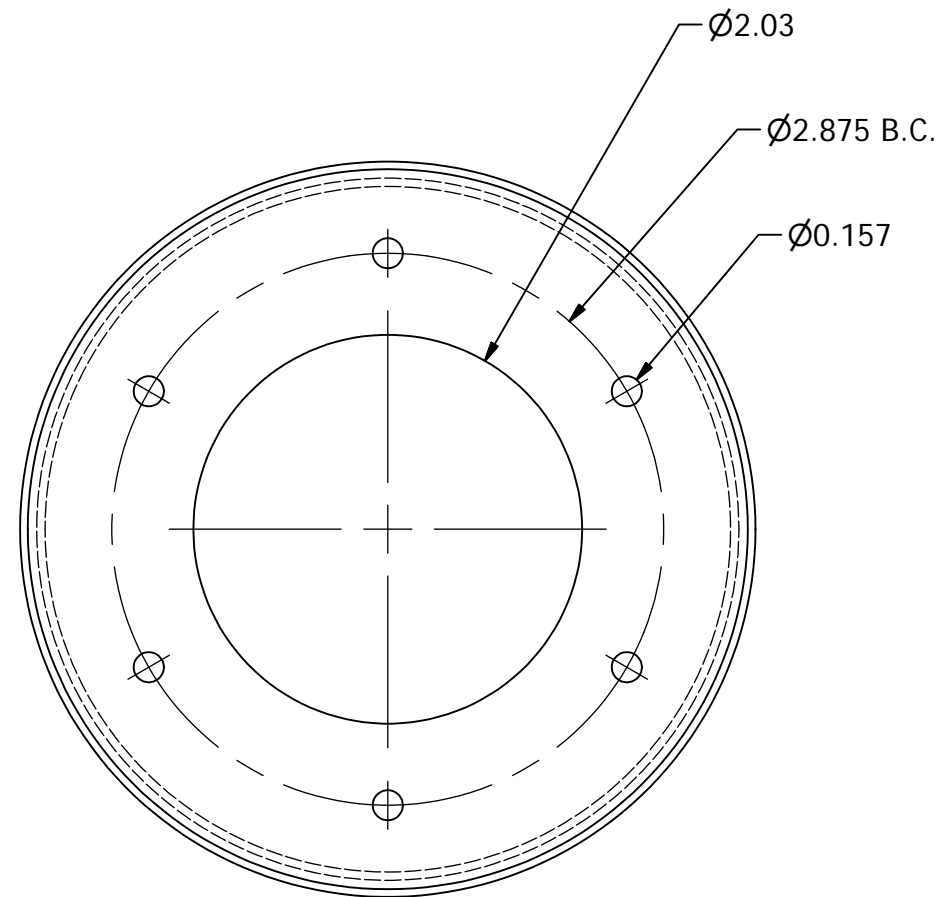

BLANK SIZE =  $\varnothing 5.5625$

DATE	SYM.	DESCRIPTION	BY
6-24-11	C	P/N WAS AFA-302--Change to match Cat.	BPK
3-12-10	B	Edit Model & Description to reflect MAT'L GA.	BPK
3-27-08	A	ADD FLARE TO REFLECT PHYSICAL PART	BPK

REVISIONS

<b>AMERICAN MOBILE POWER</b> PH: (800) 634-8265 FAX: (765) 948-3403	DRAWIND BY: MRH	DESIGN FOR: AMP	FILE NAME: AFS-301
	COMPLETED: 7/9/2003		SHEET: 1 of 1

4

3

2

1

B

B

A

A