

4

3

2

1

Parts List

ITEM	QTY	PART NUMBER	DESCRIPTION
1	1	57XL-40	40 Micron FILL w/30 Mesh Stainless Strainer
2	1	APP0750-M	3/4" NPT MAG PLUG
3	1	APP1000	1" NPT PLUG
4	1	APP1250	1 1/4" NPT SQUARE SOCKET PLUG
5	1	N_A4107	NAM WELDMENT ~14 lbs
6	1	T-LLG-5	SIGHT/TEMP. GAUGE, 5"

B

B

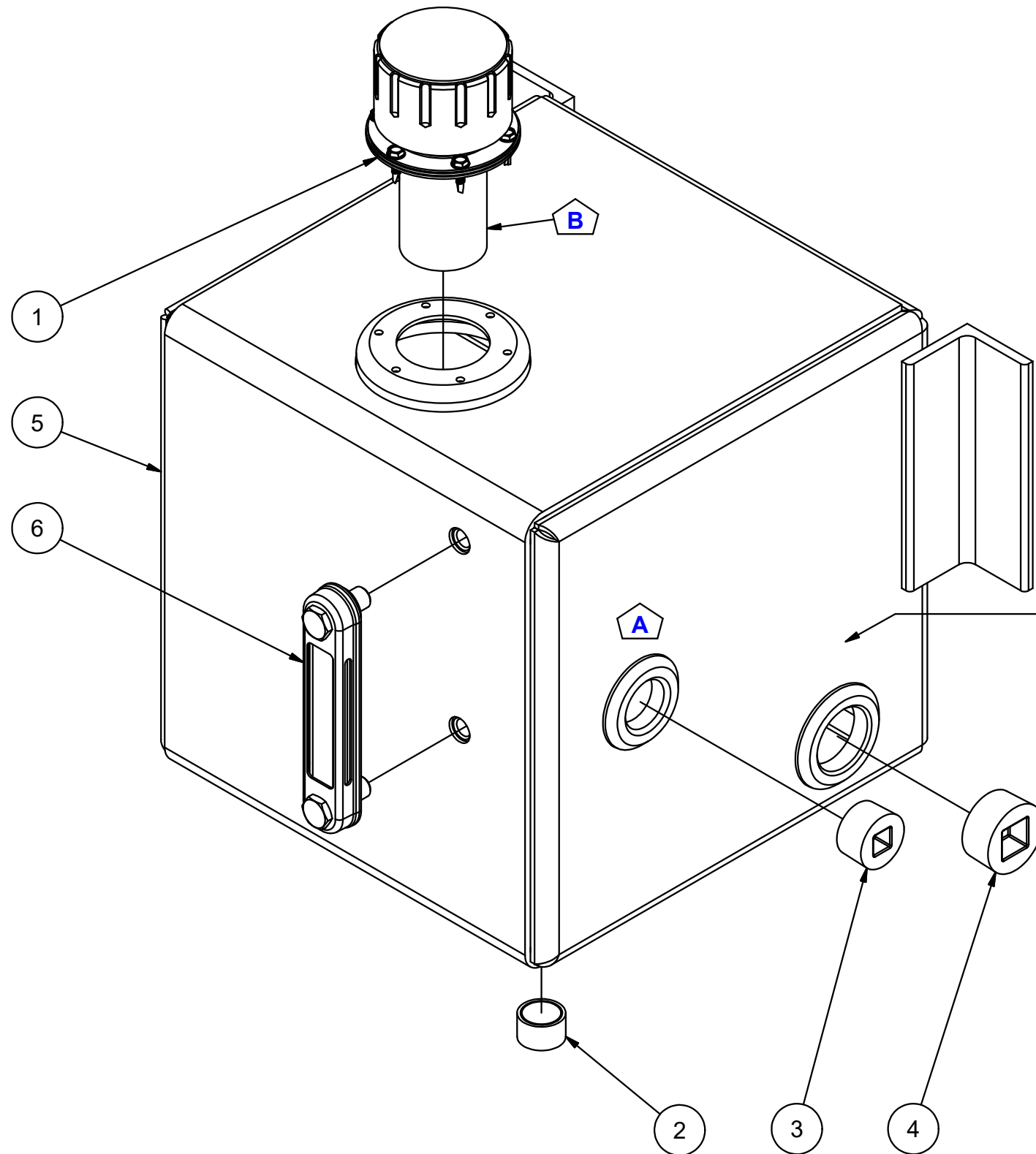

STAMP SERIAL No. HERE

A

A

WT.: ~15.5 lbs

DATE	SYM.	DESCRIPTION	BY
12-5-16	B	WAS 57XL-40N	BPK
9-15-10	A	LOWERED RETURN PORTS 3.5 INCHES	BPK

AMERICAN MOBILE POWER PH: (800) 634-8265 FAX: (765) 948-3403	DRAWING BY: MRH	DESIGN FOR: AMP	FILE NAME: A4107	
	COMPLETED: 1/17/2001		SHEET: 1 of 7	SHEET SIZE: B

4

3

2

1

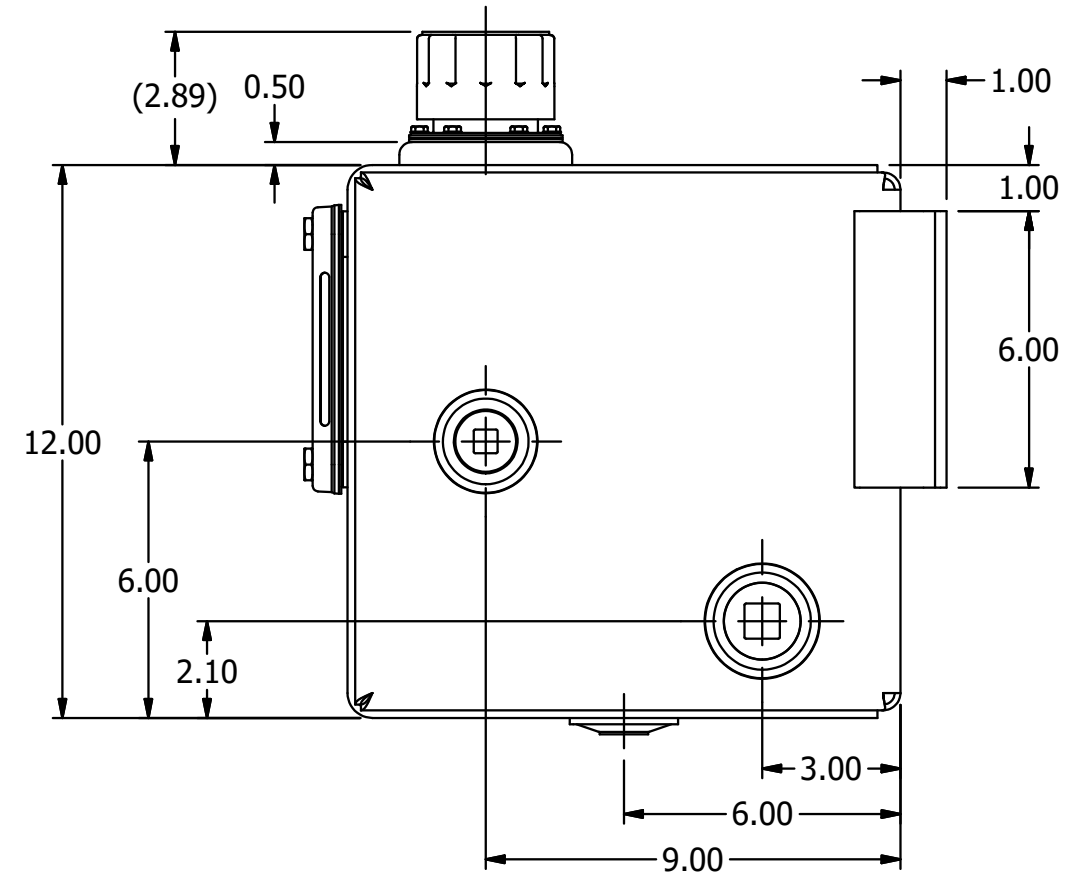
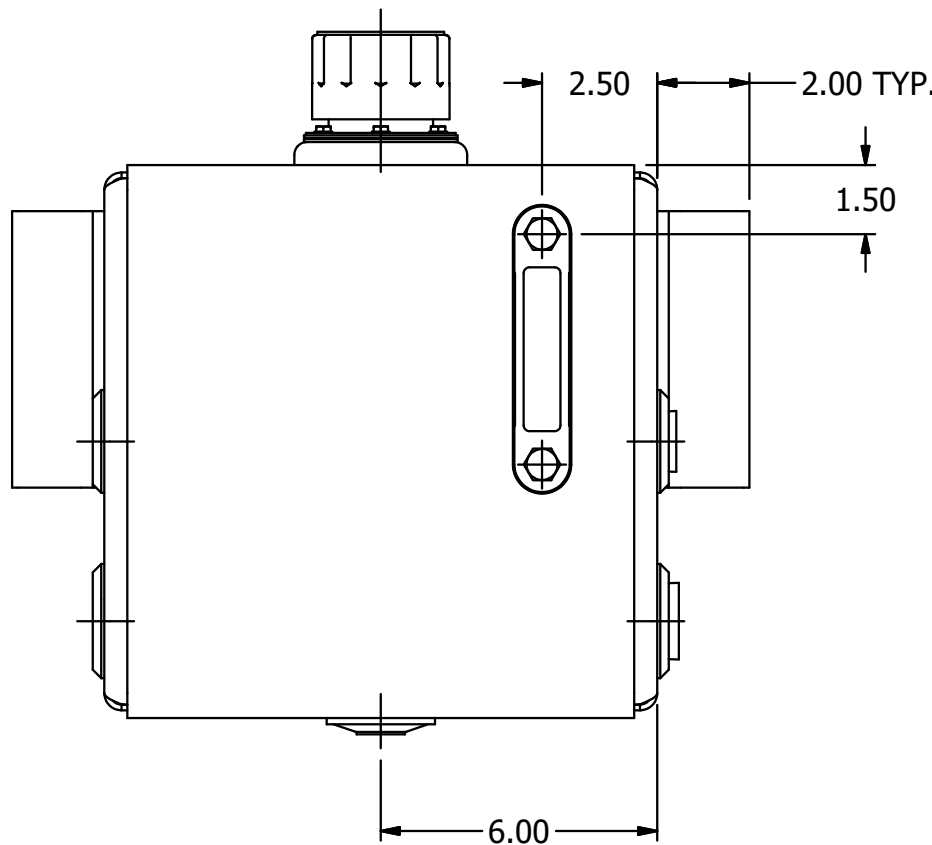
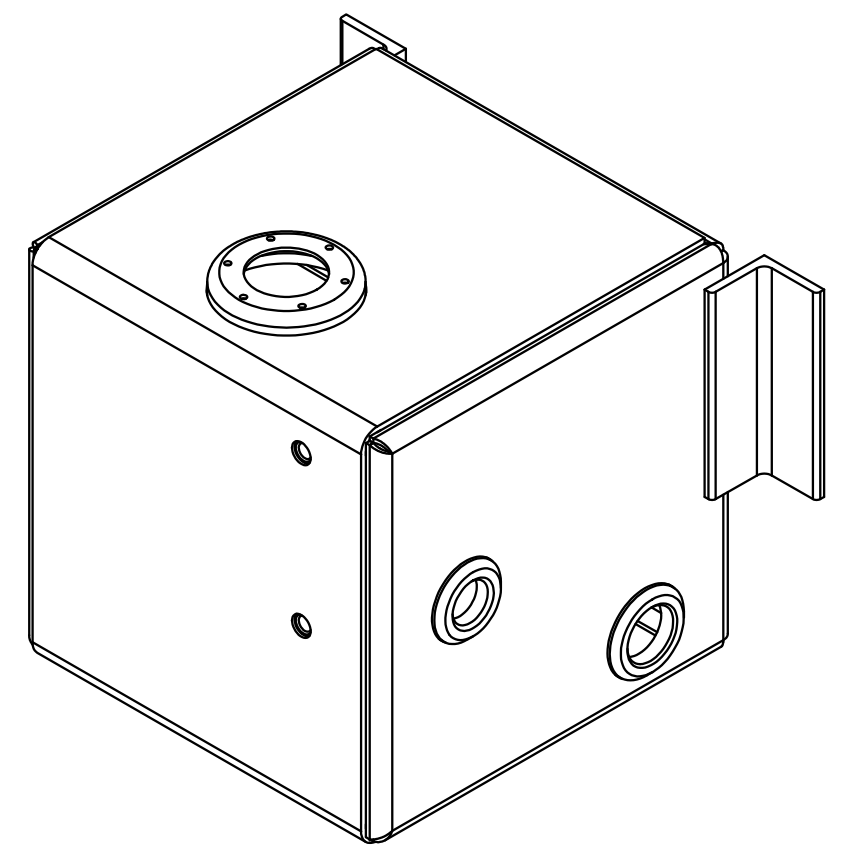
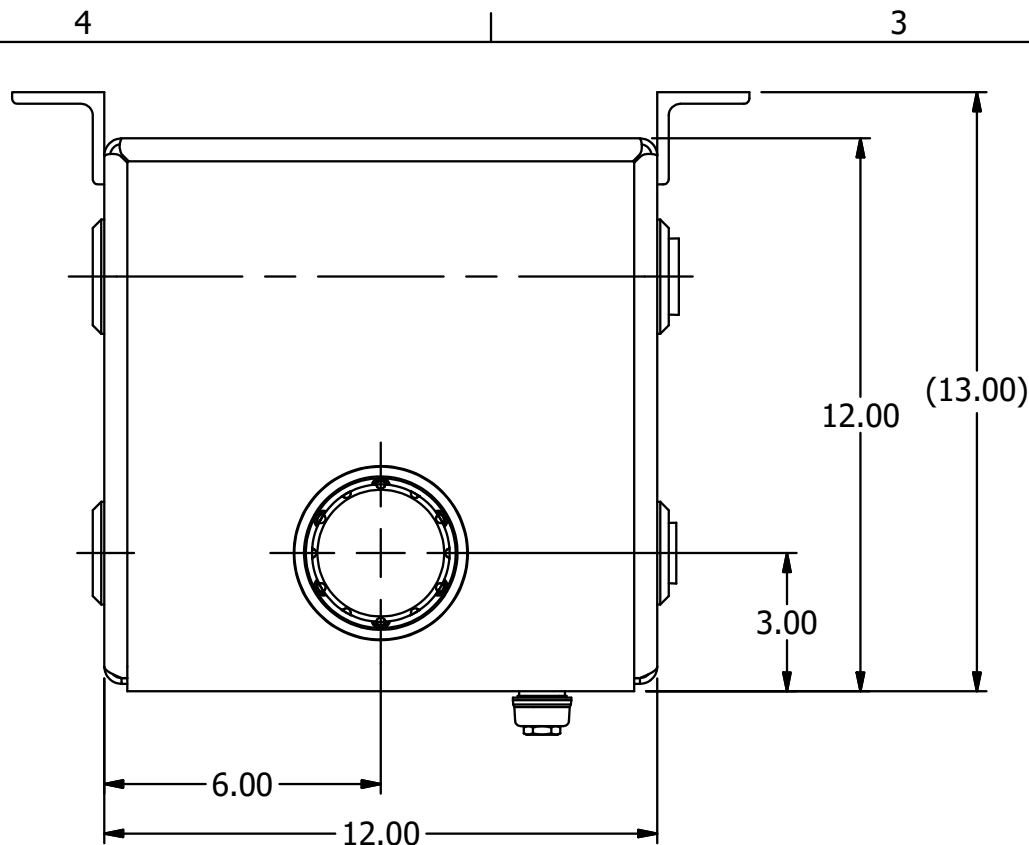

DATE	SYM.	DESCRIPTION	BY
9-15-10	A	LOWERED RETURN PORTS 3.5 INCHES	BPK

AMERICAN MOBILE POWER PH: (800) 634-8265 FAX: (765) 948-3403	DRAWING BY: MRH	DESIGN FOR: AMP	FILE NAME: A4107	
	COMPLETED: 1/17/2001		SHEET: 2 of 7	SHEET SIZE: B

4

3

2

1

Parts List

ITEM	QTY	PART NUMBER	DESCRIPTION	FAB QTY
1	2	0500-13-AWN	1/2-13 ALUMINUM WELD NUT	
2	1	A4107BF	.125 MILL ALUMINUM BAFFLE	
3	1	A4107BS	.125 MILL ALUMINUM SIDE-BACK-SIDE	
4	1	A4107FS	.125 TREAD BRITE ALUM. TOP-FRONT-BOTTOM	
5	1	AFA-401	.100 AI FILL ASS'Y WELD FLANGE	
6	2	ANGLE-AL-6IN	2 x 2 x 1/4 x 6 LG ALUMINUM ANGLE	
7	1	AWF0750	3/4" NPTF 6061-T6 WELD FLANGE	
8	2	AWF1000RM	1" NPT ALUM. WELD FLANGE REVERSE	
9	2	AWF1250RM	1-1/4" NPT AL WELD FLANGE REVERSE	

NOTE:
-PLUG ALL PORTS FOR SHIPMENT

B

B

A

A

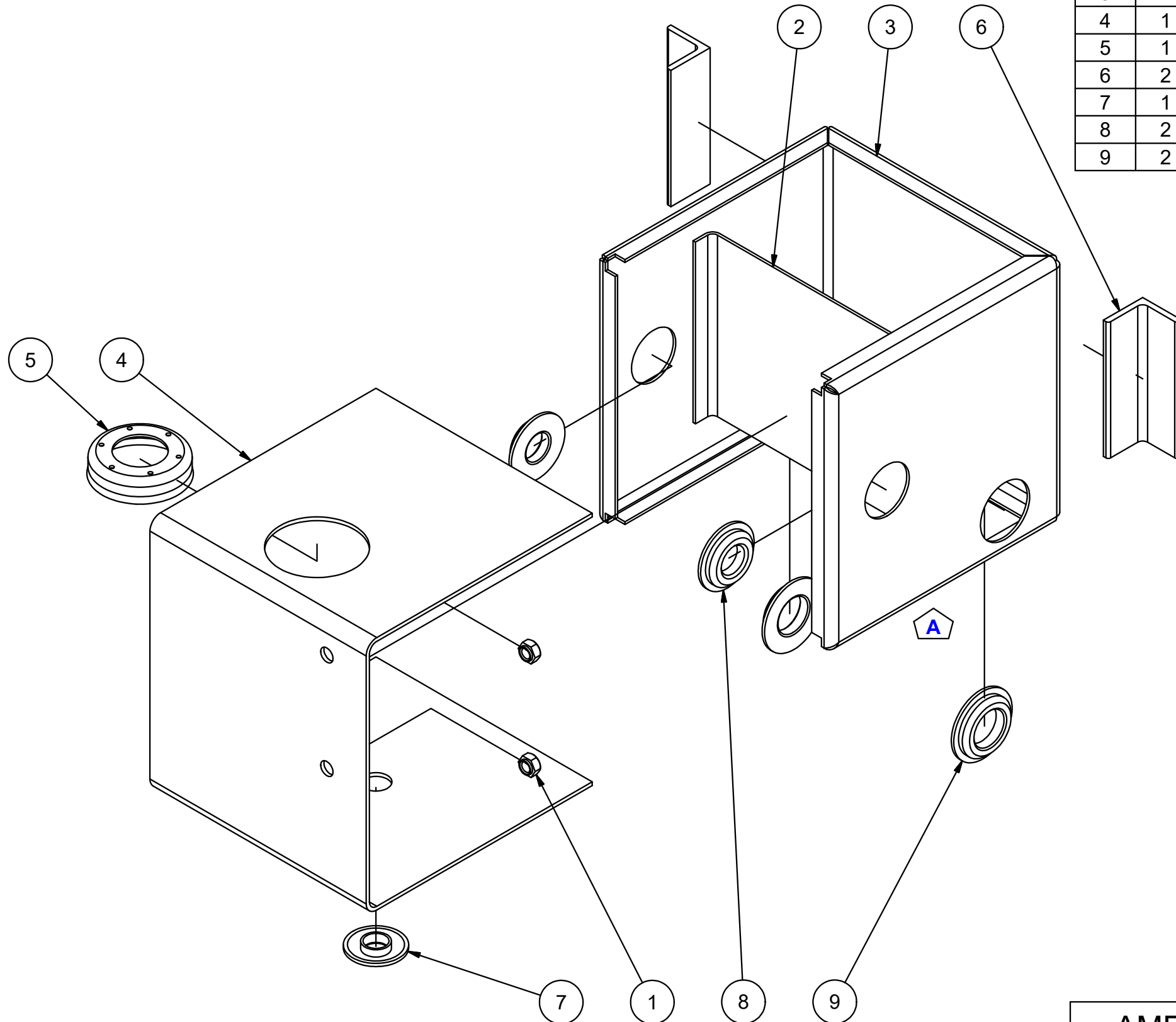

6-22-05	A	UPGRADED SIDE PORTS TO RM SERIES	BPK
DATE	SYM.	DESCRIPTION	BY

REVISIONS

AMERICAN MOBILE POWER PH: (800) 634-8265 FAX: (765) 948-3403	DRAWING BY: MRH	DESIGN FOR: AMP	FILE NAME: A4107	
	COMPLETED: 1/17/2001		SHEET: 3 of 7	SHEET SIZE: B

4

3

2

1