

4

3

2

1

Parts List

ITEM	QTY	PART NUMBER	DESCRIPTION
1	1	57XL-40	40 Micron FILL w/30 Mesh Stainless Strainer
2	1	N_A4035-ST	NAM WELDMENT ~53 1/2 lbs
3	1	T-LLG-5	SIGHT/TEMP. GAUGE, 5"

AMP PARTS INCLUDE:  
 -ASK-200 MOUNTING KIT



NOTE:  
 -PLUG ALL PORTS FOR SHIPMENT

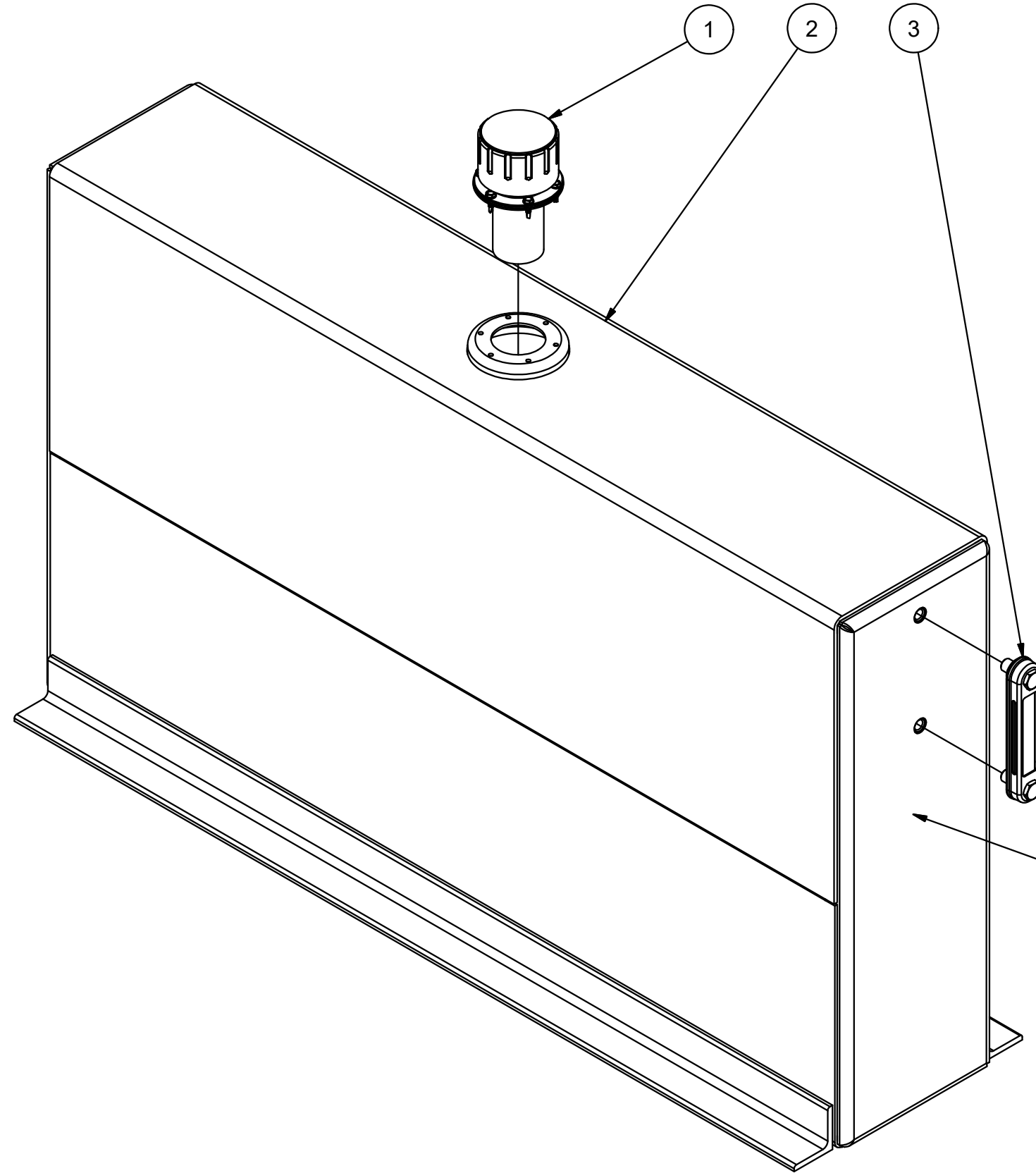

STAMP S/N ON HEAD

DATE	SYM.	DESCRIPTION	BY
9-26-18	N/A	S/N WAS ON BOTTOM OF ANGLE	BPK
6-17-15	B	ADD SUCTION SUPPORTS TO MODEL	BPK
3-8-11	A	LENGTHEN HORIZONTAL BAFFLE	BPK

<b>AMERICAN MOBILE POWER</b> PH: (800) 634-8265 FAX: (765) 948-3403	DRAWING BY: <b>BPKNIGHT</b>	DESIGN FOR: <b>AMP</b>	FILE NAME: <b>A4035-ST</b>	
	COMPLETED: <b>4/13/2010</b>		SHEET: <b>1 of 10</b>	SHEET SIZE: <b>B</b>

4

3

2

1

B

B

A

A

4

3

2

1

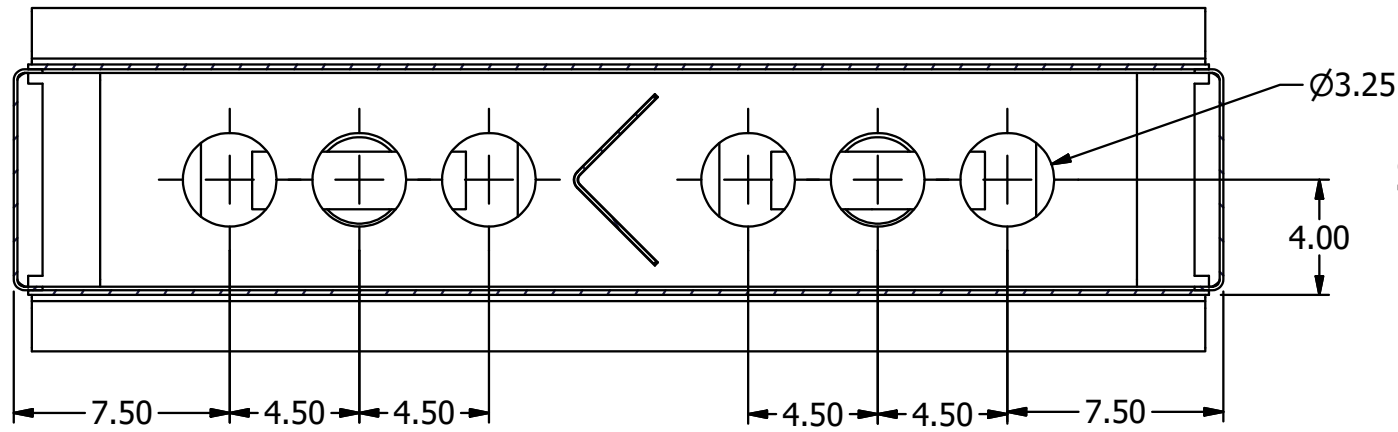

SECTION A-A

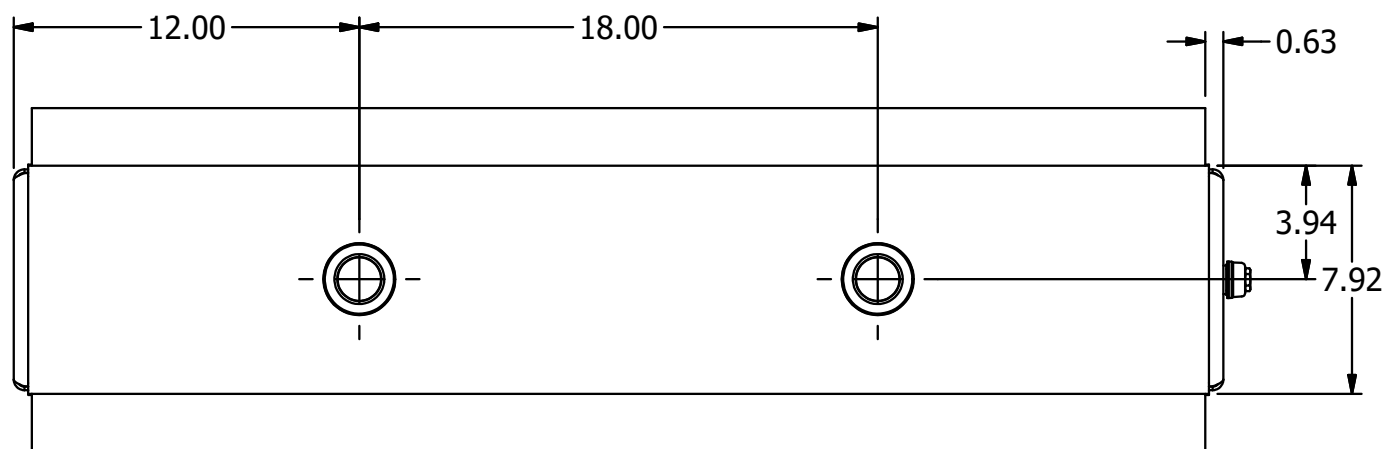
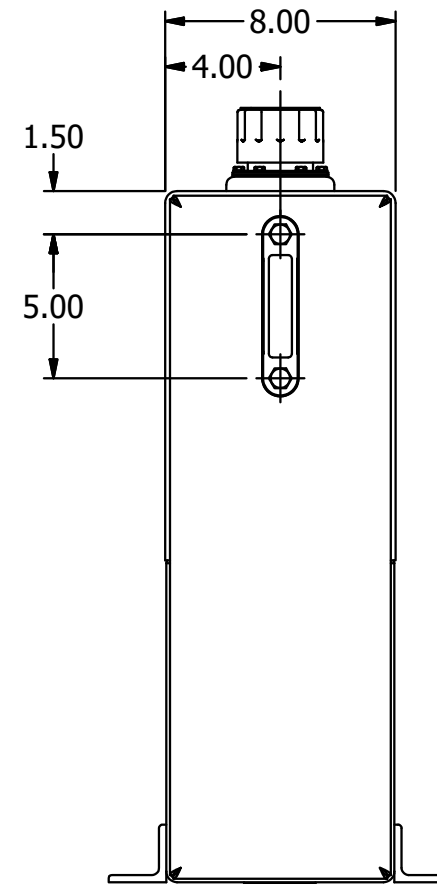
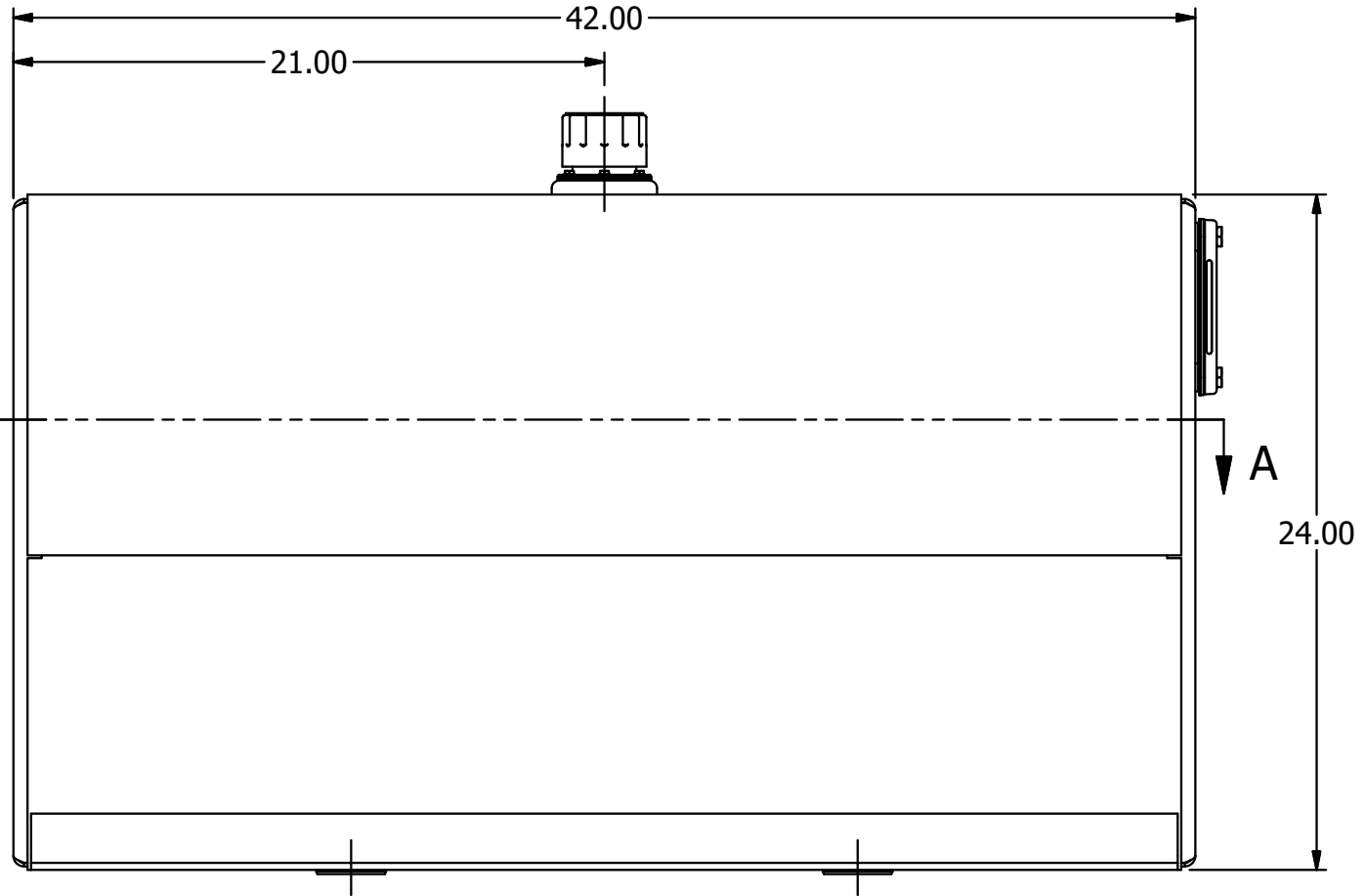

<b>AMERICAN MOBILE POWER</b> <small>PH: (800) 634-8265 FAX: (765) 948-3403</small>	DRAWING BY: BPKNIGHT	DESIGN FOR: AMP	FILE NAME: A4035-ST	
	COMPLETED: 4/13/2010		SHEET: 2 of 10	SHEET SIZE: B

4

3

2

1

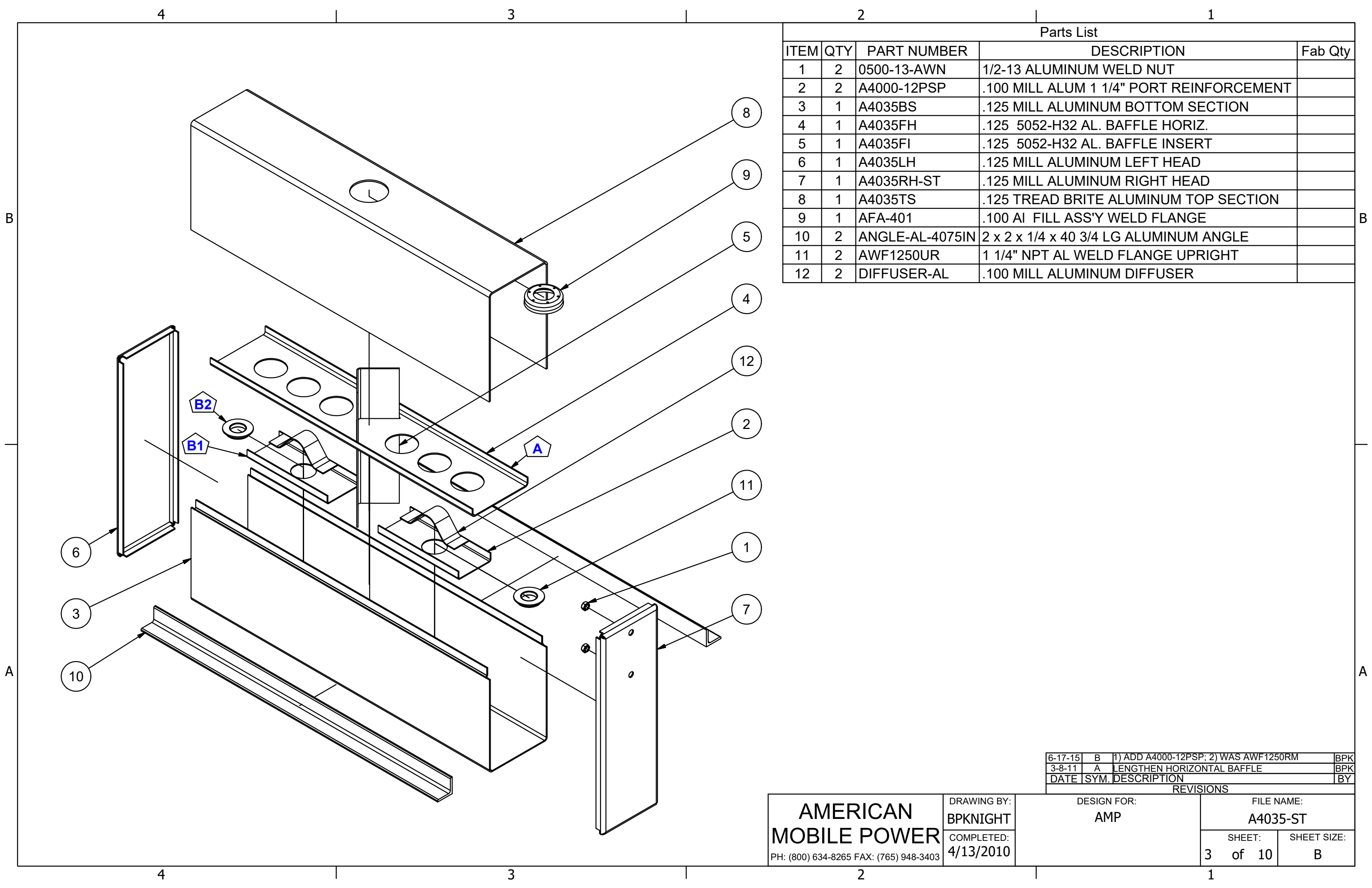

Parts List				
ITEM	QTY	PART NUMBER	DESCRIPTION	Fab Qty
1	2	0500-13-AWN	1/2-13 ALUMINUM WELD NUT	
2	2	A4000-12PSP	.100 MILL ALUM 1 1/4" PORT REINFORCEMENT	
3	1	A4035BS	.125 MILL ALUMINUM BOTTOM SECTION	
4	1	A4035FH	.125 5052-H32 AL. BAFFLE HORIZ.	
5	1	A4035FI	.125 5052-H32 AL. BAFFLE INSERT	
6	1	A4035LH	.125 MILL ALUMINUM LEFT HEAD	
7	1	A4035RH-ST	.125 MILL ALUMINUM RIGHT HEAD	
8	1	A4035TS	.125 TREAD BRITE ALUMINUM TOP SECTION	
9	1	AFA-401	.100 AI FILL ASS'Y WELD FLANGE	
10	2	ANGLE-AL-4075IN	2 x 2 x 1/4 x 40 3/4 LG ALUMINUM ANGLE	
11	2	AWF1250UR	1 1/4" NPT AL WELD FLANGE UPRIGHT	
12	2	DIFFUSER-AL	.100 MILL ALUMINUM DIFFUSER	

REVISIONS				
DATE	SYM.	DESCRIPTION	BY	
6-17-15	B	1) ADD A4000-12PSP; 2) WAS AWF1250RM	BPK	
3-8-11	A	LENGTHEN HORIZONTAL BAFFLE	BPK	

<b>AMERICAN MOBILE POWER</b> PH: (800) 634-8265 FAX: (765) 948-3403	DRAWING BY: <b>BPKNIGHT</b>	DESIGN FOR: <b>AMP</b>	FILE NAME: <b>A4035-ST</b>	
	COMPLETED: <b>4/13/2010</b>		SHEET: <b>3 of 10</b>	SHEET SIZE: <b>B</b>