

Parts List			
ITEM	QTY	PART NUMBER	DESCRIPTION
1	1	57XL-40	40 Micron FILL w/30 Mesh Stainless Strainer
2	1	APP0750-M	3/4" NPT MAG PLUG
3	1	APP1250	1 1/4" NPT SQUARE SOCKET PLUG
4	1	APP2000	2" NPT SQUARE SOCKET PLUG
5	1	N_A3300	NAM WELDMENT ~87.7 lbs
6	1	T-LLG-5	SIGHT/TEMP. GAUGE, 5"

NOTES:
 -POWDER COAT BLACK
 -APPLY RUST INHIBITOR INSIDE
 -PLUG ALL PORTS FOR SHIPMENT

STAMP SERIAL No. HERE

DATE	SYM.	DESCRIPTION	BY
9-13-18	B	ADDED S/N NOTE	BPK
7-11-07	A	ADD "HYDRAULIC OIL ONLY" STAMP	BPK
3-23-06	N/A	DEMOTED TANK ASSEMBLY TO N_A3300	BPK
3/17/05	N/A	UPDATED ASSEMBLY AND PARTS LIST	BPK

WT: ~89.94 lbs

AMERICAN MOBILE POWER PH: (800) 634-8265 FAX: (765) 948-3403	DRAWING BY: MRH	DESIGN FOR: AMP	FILE NAME: A3300	
	COMPLETED: 1/10/2001		SHEET: 1 of 7	SHEET SIZE: B

4

3

2

1

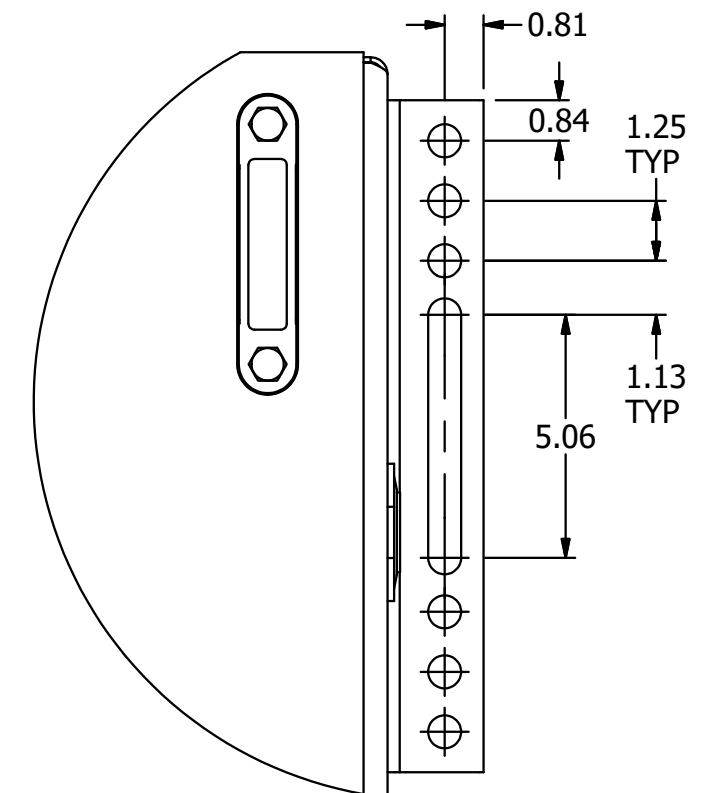
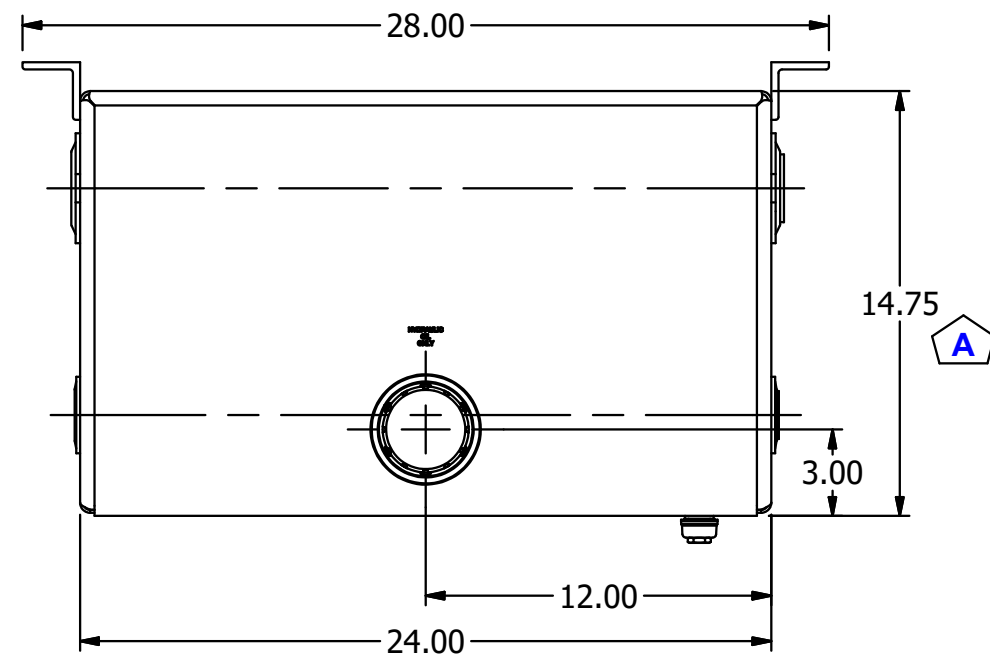

DETAIL A
SCALE 1 / 4

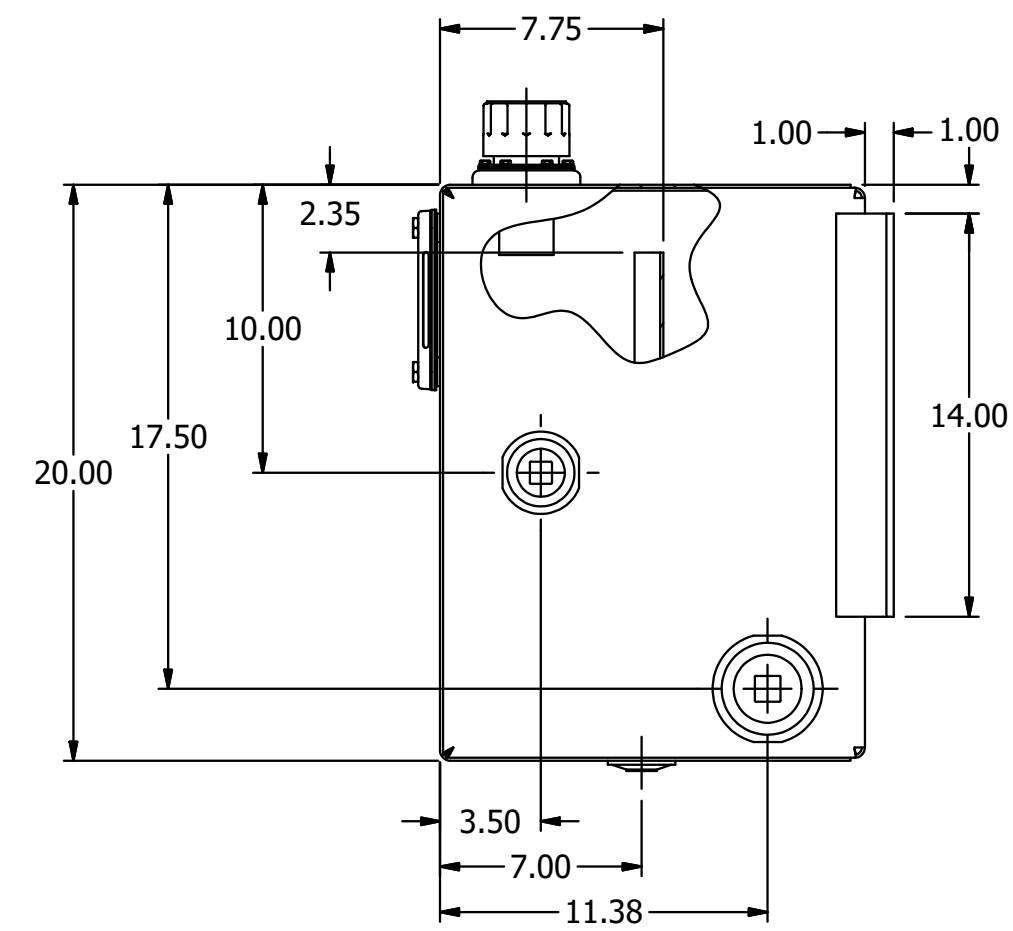
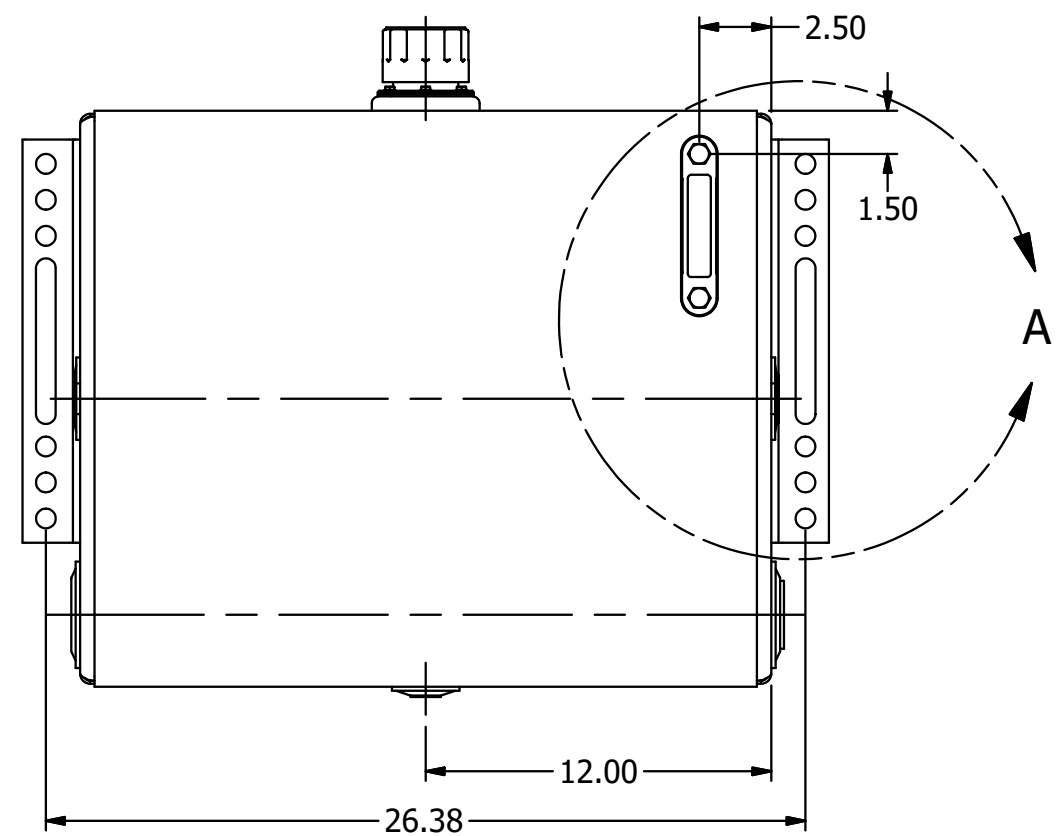

3/17/05	A	DEPTH WAS 14.87	BPK
DATE	SYM.	DESCRIPTION	BY

REVISIONS

AMERICAN MOBILE POWER PH: (800) 634-8265 FAX: (765) 948-3403	DRAWING BY: MRH	DESIGN FOR: AMP	FILE NAME: A3300	
	COMPLETED: 1/10/2001		SHEET: 2 of 7	SHEET SIZE: B

4

3

2

1

B

B

A

A

4

3

2

1

Parts List

ITEM	QTY	PART NUMBER	DESCRIPTION	Fab Qty
1	2	0500-13-FWN	1/2"-13 UNC WELD NUT	
2	1	A3300BF	12 GA HRPO BAFFLE	
3	1	A3300BS	12 GA HRPO SIDE-BACK-SIDE	
4	1	A3300FS	12 GA HRPO SIDE-FRONT-SIDE	
5	1	AFS-301	13 GA HRPO Fill Ass'y Weld Flange	
6	2	ANGLE14MFG	2 X 2 X 1/4" MFG ANGLE	
7	1	SWF0750	3/4" NPTF STEEL WELD FLANGE	
8	2	SWF1250	1 1/4" NPSC STEEL WELD FLANGE	
9	2	SWF2000	2" NPSC STEEL WELD FLANGE	

B

B

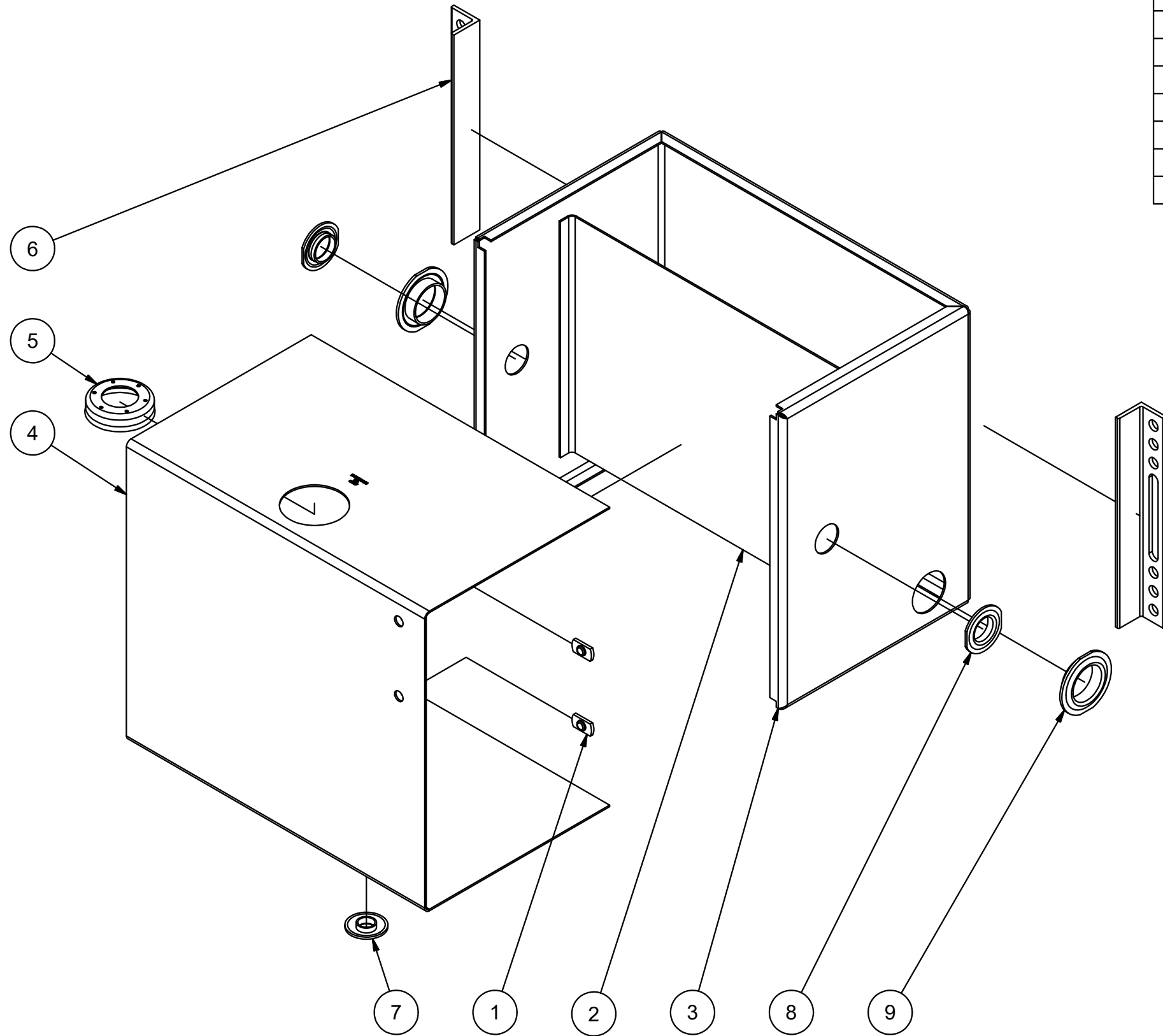

A

A

4

3

2

1

3-23-06	N/A	ADDED SHEET TO idw	BPK
DATE	SYM.	DESCRIPTION	BY

REVISIONS

AMERICAN MOBILE POWER PH: (800) 634-8265 FAX: (765) 948-3403	DRAWING BY: MRH	DESIGN FOR: AMP	FILE NAME: A3300	
	COMPLETED: 1/10/2001		SHEET: 3 of 7	SHEET SIZE: B