

4

3

2

1

Parts List

ITEM	QTY	PART NUMBER	DESCRIPTION
1	1	N_A3035-2ST	NAM WELDMENT 42W24H8D ~119 3/4 lbs
2	1	57XL-40	40 Micron FILL w/30 Mesh Stainless Strainer
3	1	T-LLG-5	SIGHT/TEMP. GAUGE, 5"

AMP PARTS TO INCLUDE:
 -ASK-200 MOUNTING KIT

NOTES:
 -POWDER COAT BLACK
 -APPLY RUST INHIBITOR INSIDE
 -PLUG ALL PORTS FOR SHIPMENT

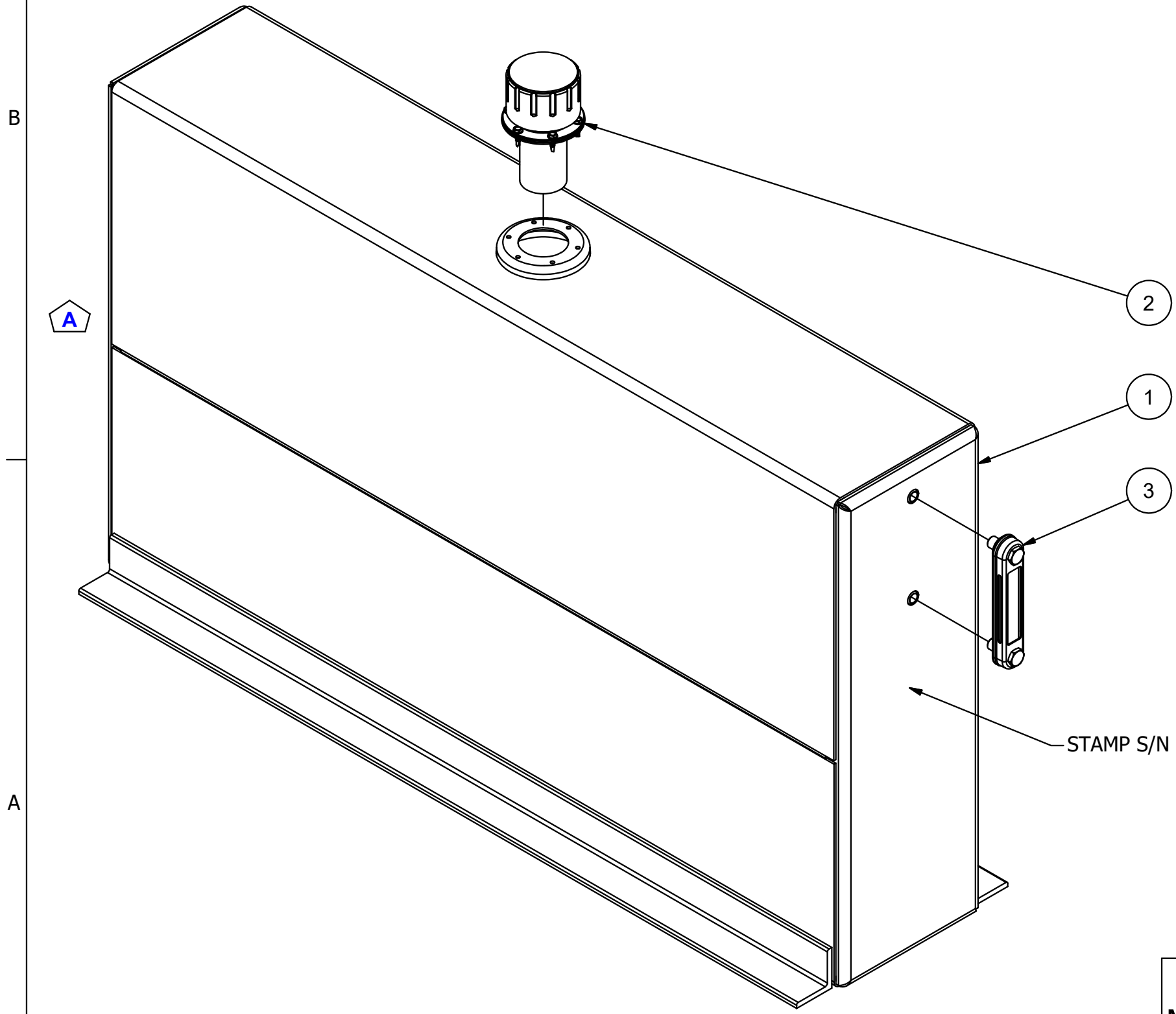

STAMP S/N ON HEAD

DATE	SYM.	DESCRIPTION	BY
9-17-18	N/A	S/N WAS ON BOTTOM OF ANGLE	BPK
6-8-11	A	UPDATE DEPICTION OF OFFSET	BPK

AMERICAN MOBILE POWER PH: (800) 634-8265 FAX: (765) 948-3403	DRAWING BY: BPKNIGHT	DESIGN FOR: AMP	FILE NAME: A3035-2ST	
	COMPLETED: 4/8/2008		SHEET: 1 of 10	SHEET SIZE: B

4

3

2

1

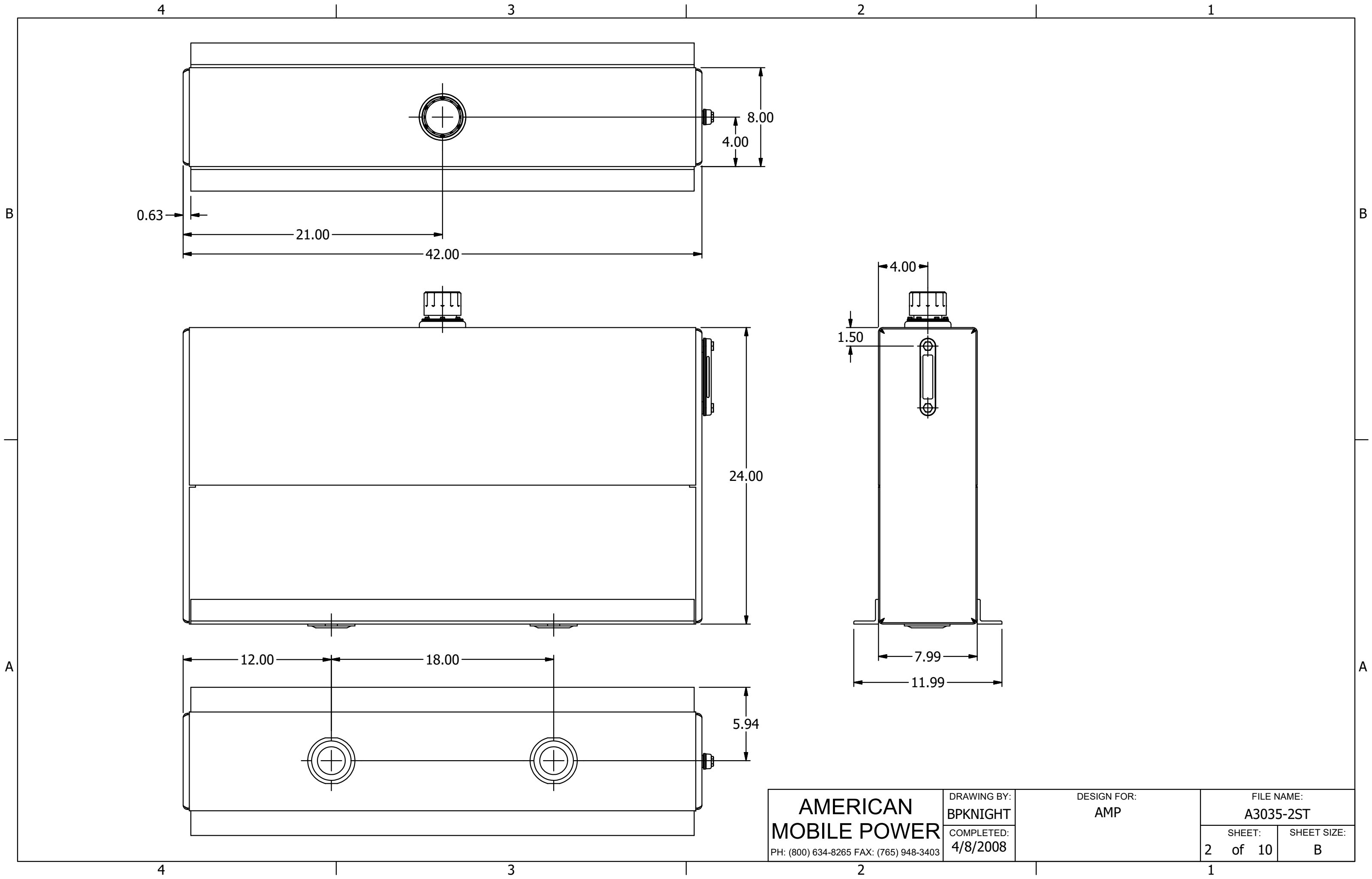

AMERICAN MOBILE POWER PH: (800) 634-8265 FAX: (765) 948-3403	DRAWING BY: BPKNIGHT	DESIGN FOR: AMP	FILE NAME: A3035-2ST	
	COMPLETED: 4/8/2008		SHEET: 2 of 10	SHEET SIZE: B

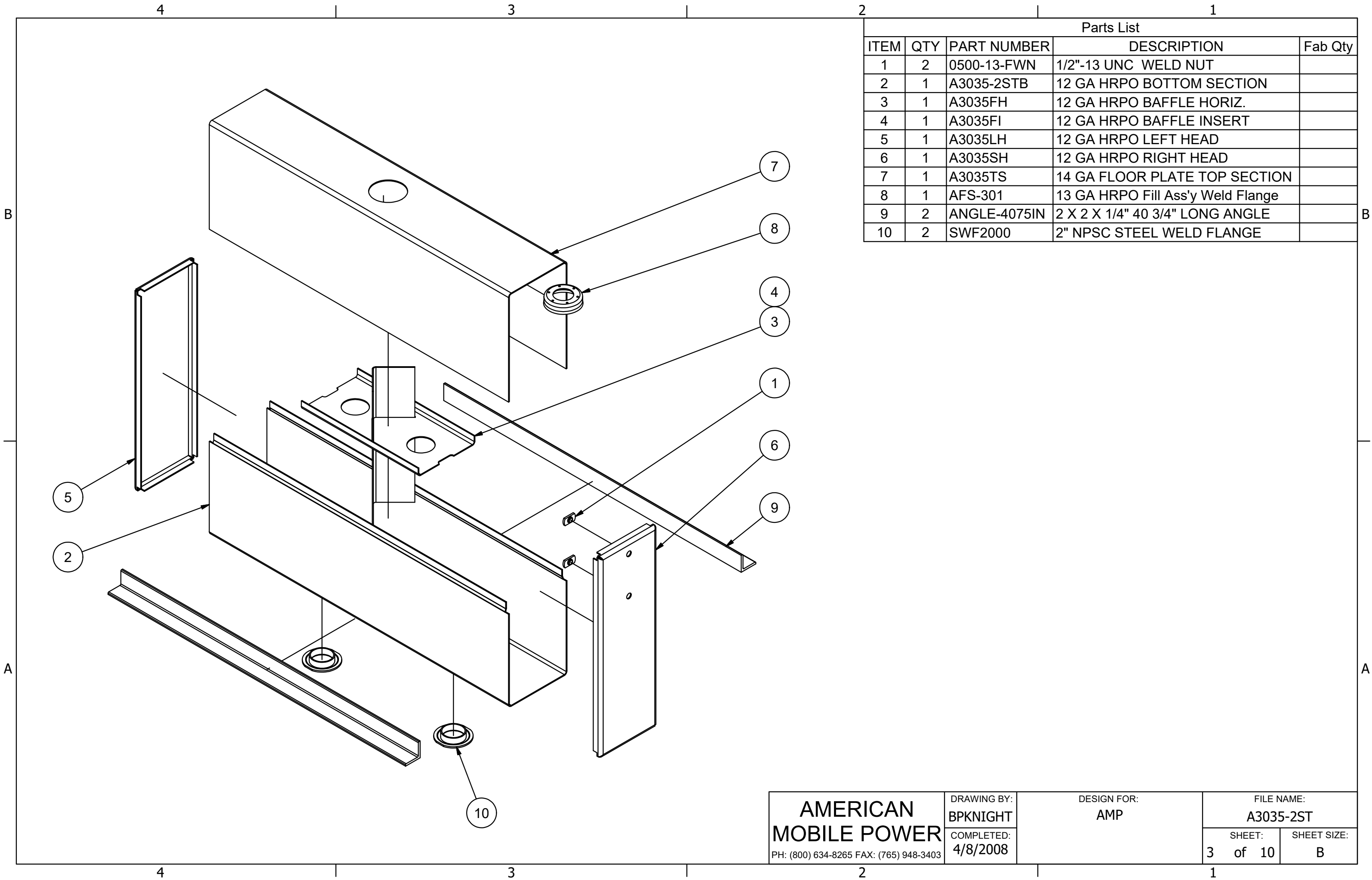

Parts List				
ITEM	QTY	PART NUMBER	DESCRIPTION	Fab Qty
1	2	0500-13-FWN	1/2"-13 UNC WELD NUT	
2	1	A3035-2STB	12 GA HRPO BOTTOM SECTION	
3	1	A3035FH	12 GA HRPO BAFFLE HORIZ.	
4	1	A3035FI	12 GA HRPO BAFFLE INSERT	
5	1	A3035LH	12 GA HRPO LEFT HEAD	
6	1	A3035SH	12 GA HRPO RIGHT HEAD	
7	1	A3035TS	14 GA FLOOR PLATE TOP SECTION	
8	1	AFS-301	13 GA HRPO Fill Ass'y Weld Flange	
9	2	ANGLE-4075IN	2 X 2 X 1/4" 40 3/4" LONG ANGLE	
10	2	SWF2000	2" NPSC STEEL WELD FLANGE	

AMERICAN MOBILE POWER PH: (800) 634-8265 FAX: (765) 948-3403	DRAWING BY: BPKNIGHT	DESIGN FOR: AMP	FILE NAME: A3035-2ST	
	COMPLETED: 4/8/2008		SHEET: 3 of 10	SHEET SIZE: B