

4

3

2

1

Parts List

ITEM	QTY	PART NUMBER	DESCRIPTION
1	1	57XL-40	40 Micron FILL w/30 Mesh Stainless Strainer
2	2	BF-16	1" NPT VENT
3	1	N_A30100-ST	NAM WELDMNT 48W30H16D ~222.2 lbs
4	1	T-LLG-5	SIGHT/TEMP. GAUGE, 5"

AMP PARTS INCLUDE:

- ASK-210 HEAVY DUTY CHASSIS MOUNTING KIT
- ASK-200G (4) GUSSETED MOUNTING ANGLES

NOTES:

- POWDER COAT BLACK
- APPLY RUST INHIBITOR INSIDE
- PLUG ALL PORTS FOR SHIPMENT

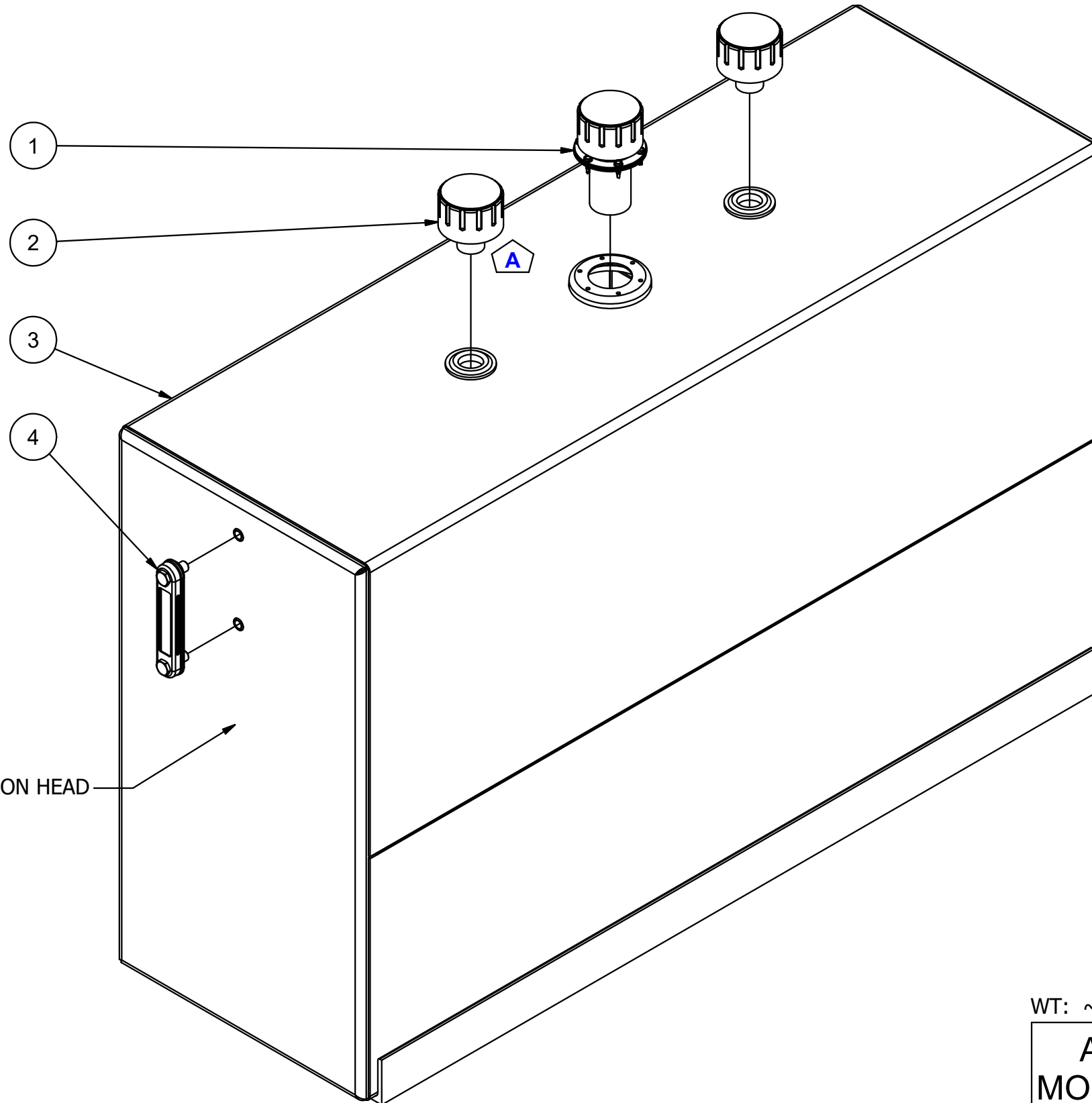

STAMP S/N ON HEAD

DATE	SYM.	DESCRIPTION	BY
9-27-18	N/A	S/N WAS ON BOTTOM OF ANGLE	BPK
5-8-14	C	MOVE BAFFLES 0.25 TO CENTER-CLEAR PORTS	BPK
3-2-11	B	VENTS WERE 3/8" NPT	BPK

REVISIONS

WT: ~223.97 lbs

<b>AMERICAN MOBILE POWER</b> PH: (800) 634-8265 FAX: (765) 948-3403	DRAWING BY: BPKNIGHT	DESIGN FOR: <b>AMP</b>	FILE NAME: A30100-ST	
	COMPLETED: 6/6/2007		SHEET: 1 of 11	SHEET SIZE: B

4

3

2

1

REVISIONS			
DATE	SYM.	DESCRIPTION	BY
5-8-14	C	MOVE BAFFLES 0.25 TO CENTER-CLEAR PORTS	BPK

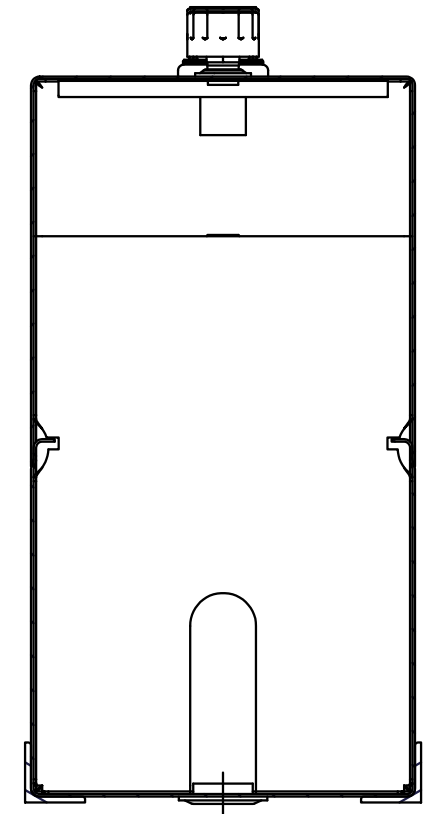
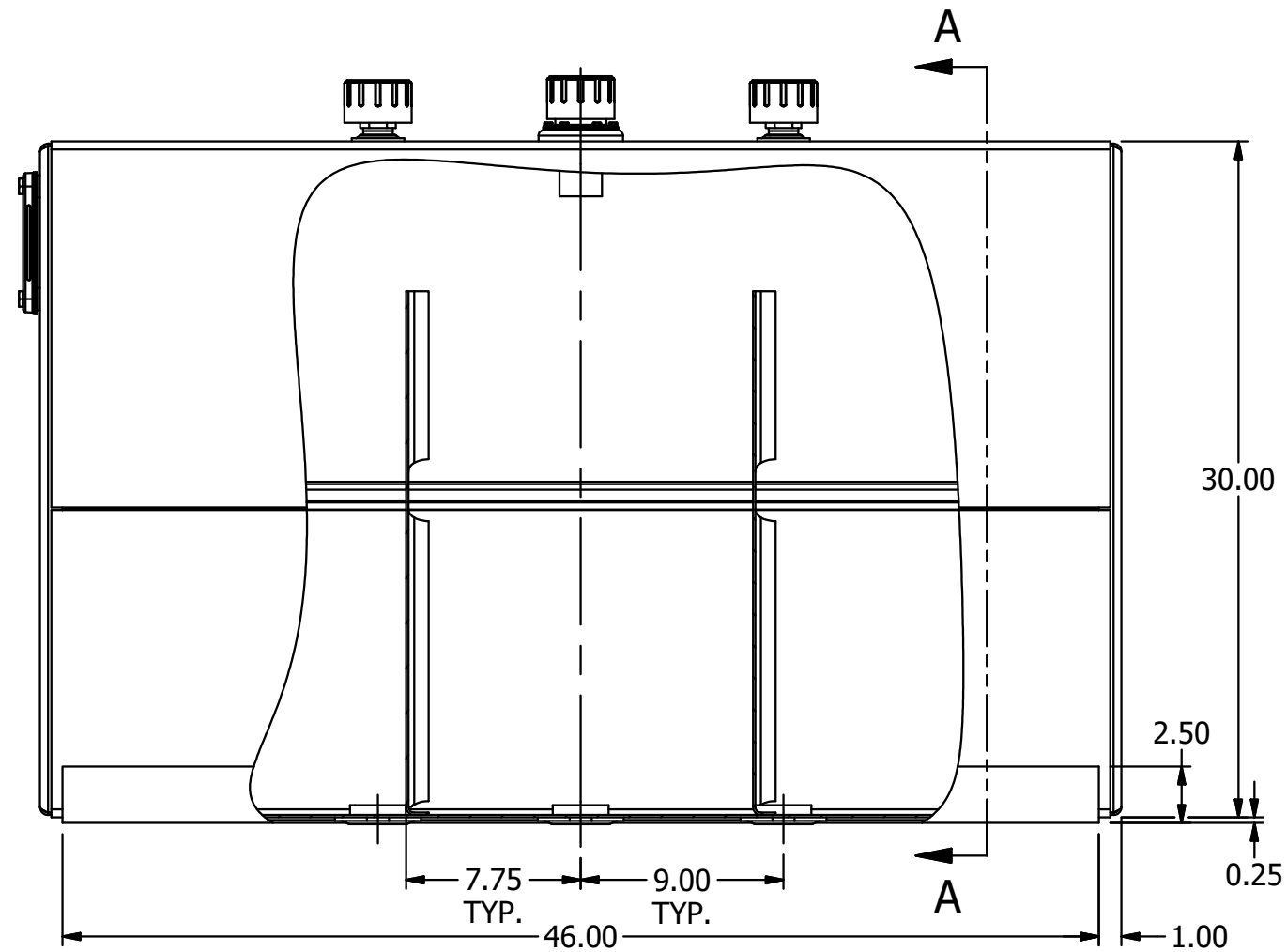
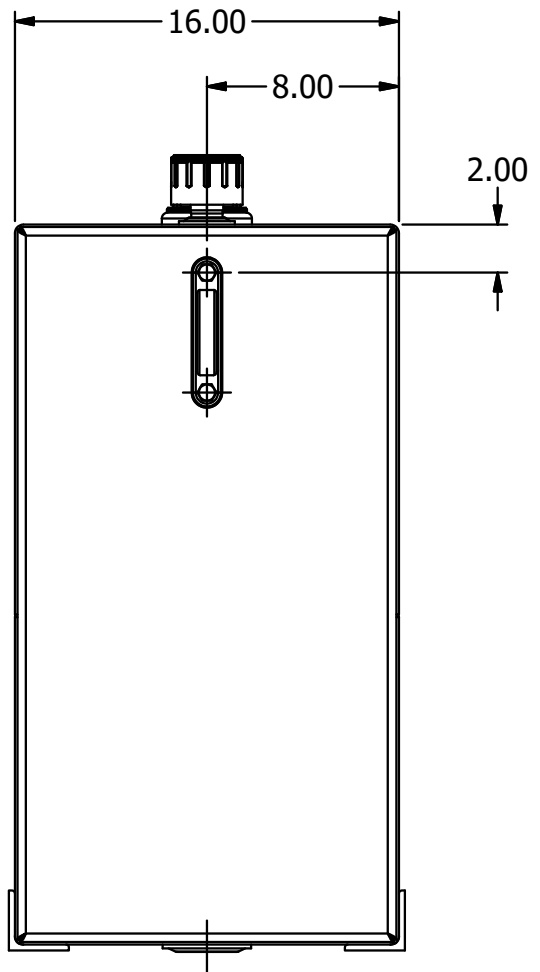
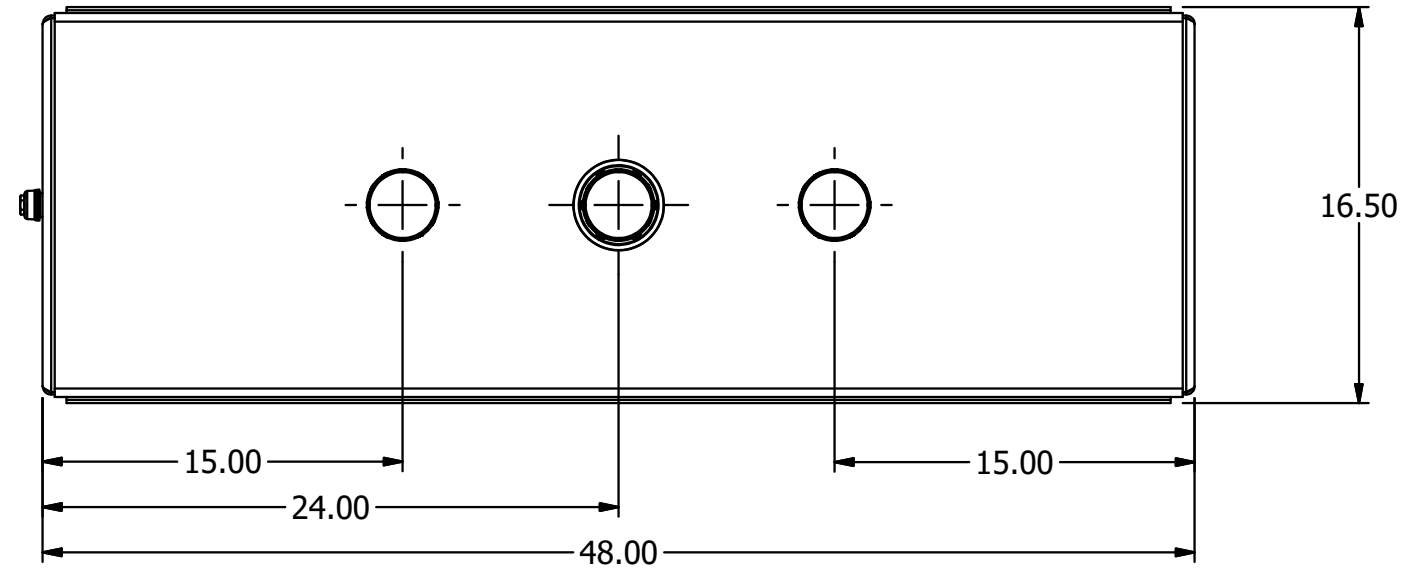

SECTION A-A

<b>AMERICAN MOBILE POWER</b> PH: (800) 634-8265 FAX: (765) 948-3403	DRAWING BY: BPKNIGHT	DESIGN FOR: AMP	FILE NAME: A30100-ST	
	COMPLETED: 6/6/2007		SHEET: 2 of 11	SHEET SIZE: B

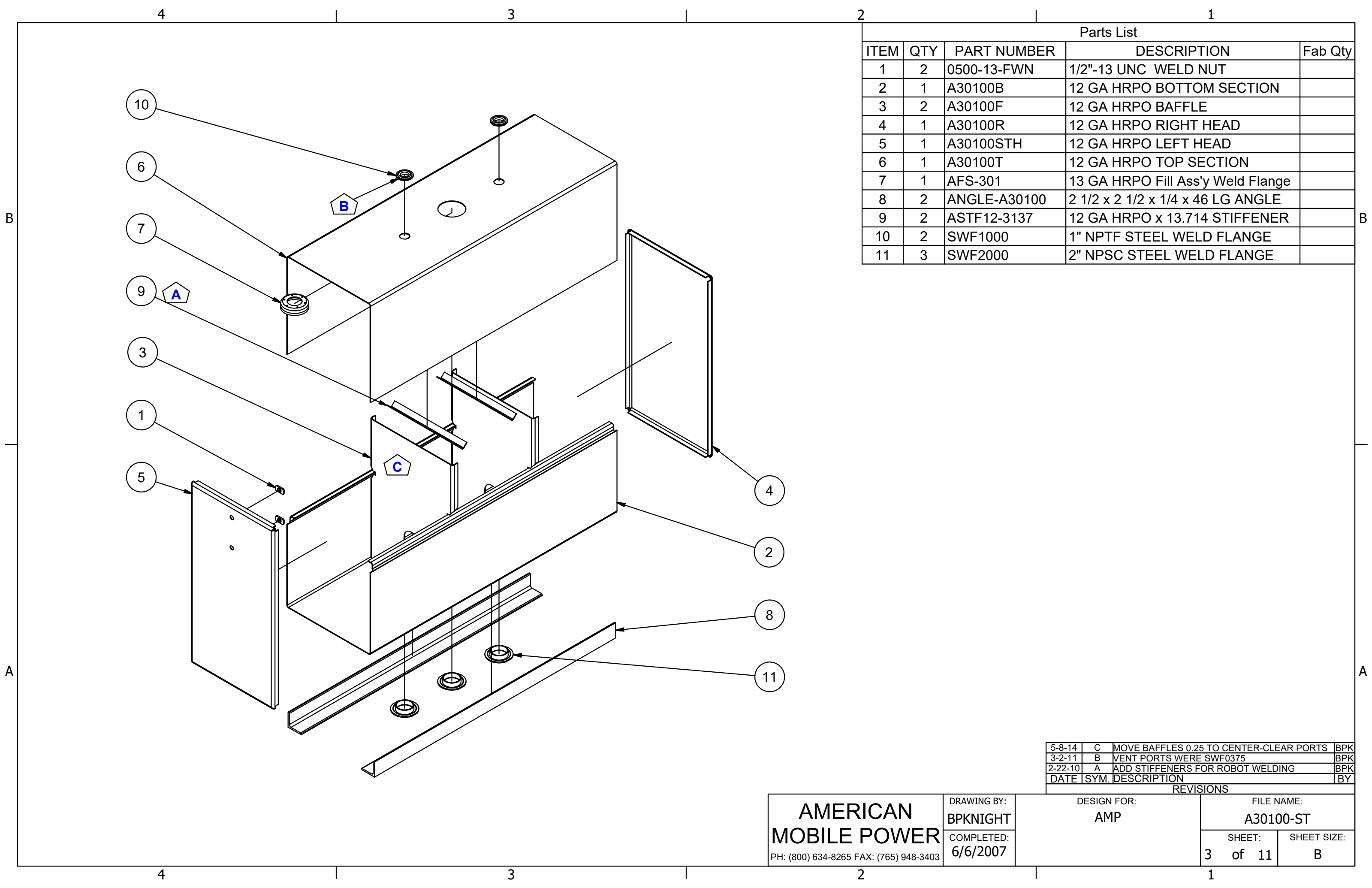

Parts List				
ITEM	QTY	PART NUMBER	DESCRIPTION	Fab Qty
1	2	0500-13-FWN	1/2"-13 UNC WELD NUT	
2	1	A30100B	12 GA HRPO BOTTOM SECTION	
3	2	A30100F	12 GA HRPO BAFFLE	
4	1	A30100R	12 GA HRPO RIGHT HEAD	
5	1	A30100STH	12 GA HRPO LEFT HEAD	
6	1	A30100T	12 GA HRPO TOP SECTION	
7	1	AFS-301	13 GA HRPO Fill Ass'y Weld Flange	
8	2	ANGLE-A30100	2 1/2 x 2 1/2 x 1/4 x 46 LG ANGLE	
9	2	ASTF12-3137	12 GA HRPO x 13.714 STIFFENER	
10	2	SWF1000	1" NPTF STEEL WELD FLANGE	
11	3	SWF2000	2" NPSC STEEL WELD FLANGE	

DATE	SYM.	DESCRIPTION	BY
5-8-14	C	MOVE BAFFLES 0.25 TO CENTER-CLEAR PORTS	BPK
3-2-11	B	VENT PORTS WERE SWF0375	BPK
2-22-10	A	ADD STIFFENERS FOR ROBOT WELDING	BPK

REVISIONS

<b>AMERICAN MOBILE POWER</b> <small>PH: (800) 634-8265 FAX: (765) 948-3403</small>	DRAWING BY: BPKNIGHT	DESIGN FOR: <b>AMP</b>	FILE NAME: A30100-ST	
	COMPLETED: 6/6/2007		SHEET: 3 of 11	SHEET SIZE: B