

STEEL  
POLYETHYLENE  
ALUMINUM  
STAINLESS  
TANKS

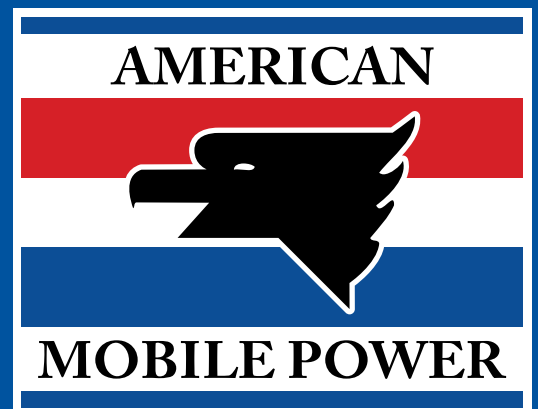

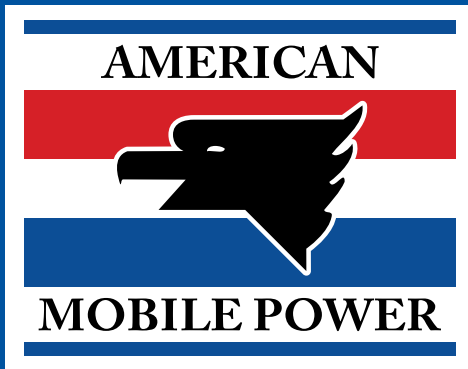

*YOUR  
JUST-IN-TIME  
SUPPLIER*



## DISTRIBUTOR PROGRAM

### **Wet Tank Systems**

American Mobile Power has developed a line of “Hydraulic Wet Tank Systems” tailored to “Just-In-Time” delivery to meet your requirements. Standard systems range from 7 to 120 gallons utilizing Polyethylene, Steel, Stainless and Aluminum materials. AMP’s standard tank systems have been designed and packaged for rapid shipment via UPS.

### **Multiple Tank Shipments**

AMP’s program provides UPS or truck freight shipment of units where and when required. Your purchase order can direct single or multiple shipments to any branch location with central or branch billing. Multiple unit orders can be “split”, with partial shipment to a branch or drop shipped to your customer.

### **Custom Tank Design**

AMP features tank systems from 7-120 gallons. Custom built tanks are available utilizing our basic steel, stainless or aluminum designs. These units can be ported, vented, and finished to your applicable specifications. Our plant provides rapid “turn-around” and competitive pricing on custom units. Call or email today for more information on Custom units!

## Limited Warranty

American Mobile Power's (AMP) Wet Tank System is warranted to be free of defects in material or workmanship and to meet AMP's written specifications at the time of sale. AMP obligation and liability under this warranty is expressly limited to repairing or replacing, at AMP's option, within one year after date of original installation, any defective part, or parts, or any product not meeting the specifications.

This warranty is in lieu of all other warranties, expressed or implied. AMP makes no warranty of merchantability, or of fitness for any particular purpose. The obligation of AMP under this warranty shall not include any transportation charges, or costs of installation or any liability for direct, indirect, special, incidental, or consequential damages, or delay. The remedies set forth herein are exclusive, and AMP's liability, with respect to any contract or sale or anything done in connection therewith, whether in contract, in tort, under any warranty, or otherwise, shall not, except as expressly provided herein, exceed the price of the product, or part, on which such liability is based.

If requested by AMP, products, or parts, for which a warranty claim is made are to be returned, transportation prepaid, to a Service Center designated by AMP. Any installation, or use, not in accordance with the catalog, or package instructions; other improper use, operation beyond an intermittent duty, substitution of parts not approved by AMP; use with equipment other than the equipment on which the Wet Tank System is first installed, or alteration, or repair, made to the unit other than at an American designated Service Facility, shall void this warranty.

## Warning

Improper selection, or improper use, of the products and/or systems described herein, or of related items, can cause death, personal injury and property damage.

This document and other information from American Mobile Power and authorized distributors provide this product and/or system options for further investigation by users having technical expertise. It is important that you analyze all aspects of your application and review the information concerning the product or system in the current product catalog. Due to the variety of operating conditions and applications for these products or systems, the user, through its own analysis and testing, is solely responsible for making the final selection of the products and systems, and for assuring that all performance, safety and warning requirements of the application are met.

**The products described herein, are subject to change by AMP at any time without notice.**

Care has been taken in preparation of this literature. American Mobile Power is not responsible for errors or omissions.

## Hydraulic Systems

### Hydraulic Tanks\*

Uprights .....	6-13
Saddlemounts.....	14-23
Sidemounts.....	24-30
Specialty .....	31-38

### Hydraulic Mounting Products

Saddlemount Mounting Kits	.39-40
Upright Mounting Kits .....	41-42
Hydraulic Mounting Parts....	43-44

### Fill Assembly Products

Fill Assemblies .....	45
Breather Assembly Parts.....	46
Hydraulic Tank Parts.....	47-48
Hydraulic Parts .....	49

### Hydraulic Hose Kits and Parts

3-line Hose Kit System .....	50
2-line Hose Kit System .....	51
Hose Support Kits .....	52
Hydraulic Accessory Parts .....	53

## Transfer Systems

### Transfer Tanks\*

Uprights .....	54-55
"L" Styles .....	56
Transfer Pumps.....	57
Transfer Parts.....	58-59

## Reefer Systems

### Reefer Tanks\*

22" Reefers .....	60
24" Reefers .....	61

### Reefer Mounting Products

Mounting Kits.....	62-63
Reefer Parts .....	64-65

## Installation

Installation Guides .....	66-78
Index .....	79-80

\* Capacities listed are dimensional and do not necessarily reflect the fluid capacities.

## Shipping Solutions

At American Mobile Power, we strive to provide our customers with the best possible solution for rapid delivery at the most cost-effective way possible. We offer a variety of shipping solutions. Including full truckload, less than truckload, air freight, small parcel package and international shipping.

AMP works with several freight carriers to provide cost effective shipping solutions at discounted rates.

### Truck Freight Options

- Customer routed using your trucks/brokers
- Internally routed using our resources
- Collect or prepay & add
- Third party billing
- Drop shipments
- Full truckload & Less than truckload

***Note: Freight can be hauled by weight, cubic feet or linear feet. This is determined by the individual carrier. American Mobile Power has no bearing on this decision and cannot be held responsible for added freight charges incurred by this.***

The transit map is approximations only. Each freight carrier will differ in transit times. Please call us for exact transit times for your location.

### Parcel Package

- We ship using UPS
- Fed-Ex & DHL if routed by customer
- Collect or prepay & add
- Third party billing
- Drop shipments
- Ground or air freight

***Note: Small package carriers invoice charges based upon the greater of actual or dimensional weight. American Mobile Power cannot be held responsible for invoiced charges compared to product weight.***

# Truck Freight Areas Served

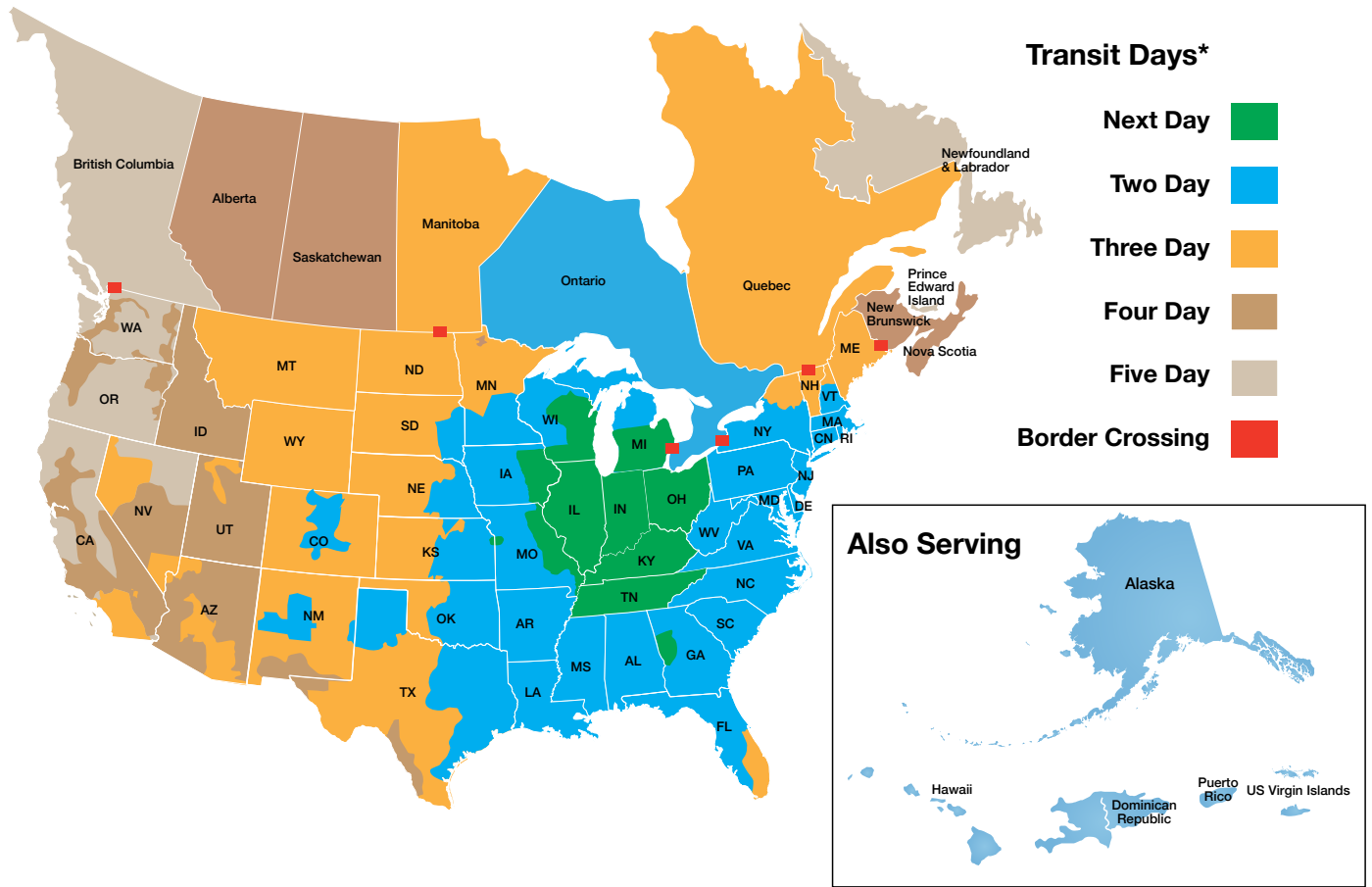

# Parcel Package Area Served

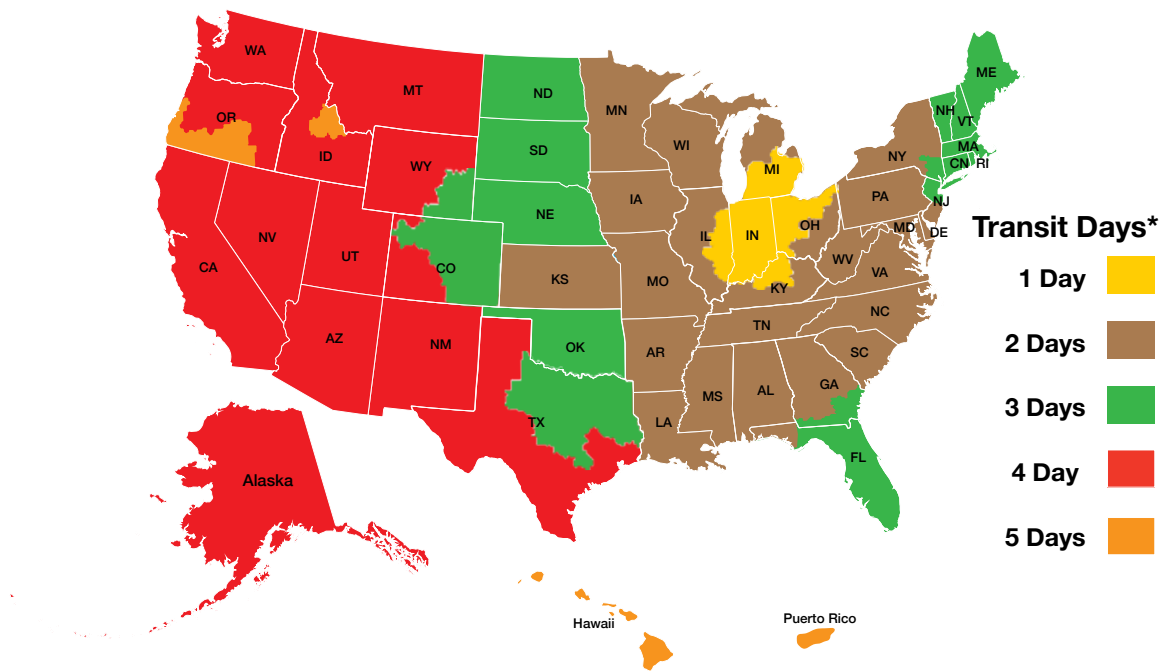

\*Shown for reference only, delivery times are approximate.

## Contact Information:

1-800-634-8265 / 765-948-3401

Fax: 765-948-3403

sales@americanmobilepower.com

www.americanmobilepower.com

### Street Address:

American Mobile Power  
619 E. Jefferson Street  
Fairmount, IN 46928

### Mailing/Remit to:

American Mobile Power  
P.O. Box 68  
Fairmount, IN 46928

### Terms:

- Open Account terms are Net 30 days.
- 1½% per month on outstanding balance until paid in full.
- F.O.B. our plant facility.
- VISA, MasterCard and American Express accepted.
- NOTE: Unless credit has been established with our company, shipment will be C.O.D. or Credit Card.

### Serial Numbers:

All tank assemblies carry an identification plate, or serial number imprinted in the tank body. No warranties will be accepted without the serial number.

### Returns:

Returns will not be accepted without a returned goods authorization number (RGA#). Restocking charges will apply to returned merchandise.

# CUSTOM TANK REQUEST FORM

## When Submitting a Request for a Custom Tank Quote, please provide the following:

- Marked-up drawings or a sketch with as many views necessary to show all of the ports and other features required. Please specify front view for reference.
- Mild Steel (HRPO), Stainless Steel (304L) or Aluminum (5052-H32) material required.
- Manufacturer's specifications for in-tank return filters and other custom accessories.

List standard tank model to customize: \_\_\_\_\_

### Step 1

Material	
Aluminum	<input type="checkbox"/>
Stainless	<input type="checkbox"/>
Steel	<input type="checkbox"/>

### Step 2

Mounting Style	
Upright	<input type="checkbox"/>
Sidemount	<input type="checkbox"/>
Saddlemount <i>(Not available in stainless)</i>	<input type="checkbox"/>

### Step 3

Dimensions	
Height (bottom to top)	_____
Width (side to side)	_____
Depth (front to back)	_____
Saddlemount	22" <input type="checkbox"/>
<i>(Only 22 or 24 inches diameter available)</i>	24" <input type="checkbox"/>

### Step 5

Options for Assemblies, Parts and Kits	
Type, Quantity & Location	_____
Type, Quantity & Location	_____
Type, Quantity & Location	_____
Type, Quantity & Location	_____
Type, Quantity & Location	_____
Type, Quantity & Location	_____
Type, Quantity & Location	_____

### Step 4

Porting, Vents	
Type	_____
Quantity	_____
Size	_____
Location	_____
<hr/>	
Type	_____
Quantity	_____
Size	_____
Location	_____

This form is available online at  
[www.americanmobilepower.com/custom](http://www.americanmobilepower.com/custom)

Step 6 Photocopy this page and send via fax 765-948-3403  
or email to: [designs@americanmobilepower.com](mailto:designs@americanmobilepower.com)

## Model A2000

### Polyethylene Upright - 50 Gallon

Tank Size: 36" long x 16½" wide x 26¼" high  
 Product Weight: 80#

Polyethylene tank assembly with two, 2" female screw-in NPT bottom ports; filler breather assembly – including 40 micron filler breather cap (chain mounted); heavy-duty mounting base; one, 2" x 1¼" reducer bushing; and an ASK-200 mounting and spring kit. A diffuser is also included with purchase

This unit may be used for a two-line or three-line system. The base and fill assembly are factory installed and mounted. Diffuser, fill cap, reducer bushing and mounting kit are boxed individually. All are shipped in one carton. Temperature/level indicator included.



TO SEE OUR FULL LINE OF DRAWINGS, GO TO [WWW.AMERICANMOBILEPOWER.COM](http://WWW.AMERICANMOBILEPOWER.COM)

Order No.	Product Weight	Description	Page #
ASK-200	12#	Chassis Mounting Kit	44
ARB-2125	1#	Port Reducer Bushing – plated, 2" x 1¼"	49
ADA-250	2#	Diffuser Assembly – 8" long – 2" x 1¼"	47
ABC-315	1#	Filler Breather Cap Only, Same All Assembly	46
AFC-330	2#	Fill Assembly	45
AMB-312	20#	Mounting Base Panel – 39.5L x 16W	43

**ALL TANKS FACTORY TESTED**



# Model A3000

## Steel Upright - 50 Gallon

Tank Size: 35½" long x 13" wide x 26¼" high  
 Product Weight: 124#

Steel tank assembly with diamond plate top section; fully baffled bottom section; two, 1¼" NPT female or screw in bottom ports, internally diffused; dual mounting rails (2" x 2" x ¼") welded to tank assembly. Tank is powder-coated black. Features filtered breather vent in tank top for increased air exchange; filler breather assembly – including 40 micron filler breather cap (chain-mounted) with stainless strainer basket and bayonet closure. ASK-200 Mounting and Spring Kit includes four, pre-drilled, powder-coated mounting angles; plated bolts; washers; Nyloc nuts; and four, plated springs. The mounting kit is boxed and shipped in the tank assembly carton. The complete unit is packaged in a single carton and shipped via UPS.



A3000-ST

### Ordering Options

Product	Product Description
A3000	1¼" NPT bottom ports
A3000-ST	1¼" NPT bottom ports and Sight Temperature Gauge
A3000-15	1½" NPT bottom ports
A3000-15ST	1½" NPT bottom ports and Sight Temperature Gauge
* A3000-2	2" NPT bottom ports
* A3000-2ST	2" NPT bottom ports and Sight Temperature Gauge

*"2" Ports are non-diffused*

TO SEE OUR FULL LINE OF DRAWINGS, GO TO [WWW.AMERICANMOBILEPOWER.COM](http://WWW.AMERICANMOBILEPOWER.COM)

Order No.	Product Weight	Description	Page #
ABA-138	12#	Breather Vent – ¾" NPT	46
ASK-200	1#	Chassis Mounting Kit	44
ABC-315	2#	Filler Breather Cap Only	46
AFC-330	1#	Fill Assembly	45

ALL TANKS FACTORY TESTED



## Model A3035-2ST

### Steel Upright - 35 Gallon

Tank Size: 42" long x 8" wide x 24" high  
Product Weight: 120#

Steel tank assembly with diamond plate top section; fully baffled. Two, 2" NPT bottom ports, dual mounting rails (2" x 2" x 1/4") welded to tank assembly. Tank is powder-coated black. Filler breather assembly – including 40 micron filler breather cap (chain mounted) with stainless strainer basket and bayonet closure. ASK-200 Mounting and Spring Kit includes four, pre-drilled, powder-coated mounting angles; plated bolts; washers; Nyloc nuts; four, plated springs; and four, pre-drilled mounting pads. The mounting kit is boxed and shipped in the tank assembly carton. Oil and temperature level indicator is included. The complete unit is packaged in one carton and shipped via UPS.



TO SEE OUR FULL LINE OF DRAWINGS, GO TO [WWW.AMERICANMOBILEPOWER.COM](http://WWW.AMERICANMOBILEPOWER.COM)

Order No.	Product Weight	Description	Page #
ASK-200	12#	Chassis Mounting Kit	44
ABC-315	1#	Filler Breather Cap Only	46
AFC-330	2#	Fill Assembly	45

ALL TANKS FACTORY TESTED

# Model A3070

## Steel Upright - 70 Gallon

Tank Size: 50½" long x 13" wide x 26" high

Product Weight: 140#

Mounting Kit Weight: 52#

Total steel construction; top tank section built of Bright Diamond Plate; fully baffled. Two, 1½" NPT bottom ports, internally diffused. Tank assembly powder-coated black. Features filtered breather vent in tank top for increased air exchange. Filler breather assembly - including 40 micron filter breather cap (chain mounted) with stainless strainer basket and bayonet closure. Base assembly carton includes mounting base, carbon steel strap assembly and rubber mounting pads. Mounting kit includes four, pre-drilled powder-coated mounting angles; plated bolts; washers; Nyloc nuts; four, plated springs; and four, pre-drilled mounting pads. Mounting kit (ASK-200) is boxed and shipped in the base carton. Complete unit is boxed and shipped in two cartons and shipped via UPS.



A3070 shown

### Ordering Options

Product	Product Description
A3070	1½" NPT bottom ports
A3070-ST	1½" NPT bottom ports and Sight Temperature Gauge
* A3070-2	2" NPT bottom ports
* A3070-2ST	2" NPT bottom ports and Sight Temperature Gauge

*"2" Ports are non-diffused*

TO SEE OUR FULL LINE OF DRAWINGS, GO TO [WWW.AMERICANMOBILEPOWER.COM](http://WWW.AMERICANMOBILEPOWER.COM)

Order No.	Product Weight	Description	Page #
ABA-138	1#	Breather Vent - ¾"	46
ASK-200	12#	Chassis Mounting Kit	44
ABC-315	1#	Filler Breather Cap Only	46
AFC-330	2#	Fill Assembly	45
ABK-340-C	52#	Mounting Base Kit Complete	41
AMT-307	135#	Upright Steel Tank Only	N/A

**ALL TANKS FACTORY TESTED**

OPTION: Available with stainless steel straps.

## Model A30100-ST

### Steel Upright - 100 Gallon

Tank Size: 48" long x 16½" wide x 30" high  
 Product Weight: 225#

Steel tank assembly, fully baffled. Two, 2" NPT bottom ports; one, 2" NPT bottom center drain port. Tank assembly is powder-coated black. Two, filtered breather vents in tank top for increased air exchanged. Filler breather assembly, including 40 micron filler breather cap (chain mounted) with stainless strainer basket and bayonet closure. Two, base angles welded to tank body; four, 2.5" x 2.5" x 4" gusseted mounting angles shipped loose. Mounting kit (ASK-210), fill assembly, port plug and breather vents are packaged in a separate carton. Oil and temperature level indicator included. Complete tank assembly and carton are skid mounted for truck freight.



TO SEE OUR FULL LINE OF DRAWINGS, GO TO [WWW.AMERICANMOBILEPOWER.COM](http://WWW.AMERICANMOBILEPOWER.COM)

Order No.	Product Weight	Description	Page #
ABA-16	1#	Breather Vent – 1" NPT	46
ASK-210	12#	Heavy-duty Chassis Mounting Kit	44
ABC-315	1#	Filler Breather Cap Only	46
AFC-330	2#	Fill Assembly	45
ASG-105	1#	Sight/Temperature Gauge	47
ASK-200G	12#	2.5" x 2.5" x 4" Gusseted Mounting Kit	44

**ALL TANKS FACTORY TESTED**

# Model A4000

## Aluminum Upright - 50 Gallon

Tank Size: 35¼" long x 13" wide x 26¼" high  
 Product Weight: 60#

Total aluminum construction; top tank section built of Bright Diamond Plate balance bright mill finish; fully baffled. Two, heavy-duty machined 1¼" NPT bottom ports, internally diffused. Features 1" filtered breather vent in tank top for increased air exchange. Filler breather assembly – including 40 micron filler breather cap (chain mounted) with stainless strainer basket and bayonet closure. Dual mounting rails (2" x 2" x ¼") welded to tank body. Mounting kit includes four, pre-drilled, powder-coated mounting angles; plated bolts; washers; lock-nuts; four, plated springs; and four, pre-drilled mounting pads. Mounting kit (ASK-200) is boxed and shipped in the tank assembly carton. Complete unit is packaged in one carton and shipped via UPS.



A4000-ST shown

### Ordering Options

Product	Product Description
A4000	1¼" NPT bottom ports
A4000-ST	1¼" NPT bottom ports and Sight Temperature Gauge
A4000-15	1½" NPT bottom ports
A4000-15ST	1½" NPT bottom ports and Sight Temperature Gauge
* A4000-2	2" NPT bottom ports
* A4000-2ST	2" NPT bottom ports and Sight Temperature Gauge

"2" Ports are non-diffused

TO SEE OUR FULL LINE OF DRAWINGS, GO TO [WWW.AMERICANMOBILEPOWER.COM](http://WWW.AMERICANMOBILEPOWER.COM)

Order No.	Product Weight	Description	Page #
ABA-16	1#	Breather Vent – 1" NPT	46
ASK-200	12#	Chassis Mounting Kit	44
ABC-315	1#	Filler Breather Cap Only	46
AFC-330	2#	Fill Assembly	45

ALL TANKS FACTORY TESTED

## Model A4035-ST

### Aluminum Upright - 35 Gallon

Tank Size: 42" long x 8" wide x 24" high  
 Product Weight: 55#

Total aluminum construction; top tank section built of Bright Diamond Plate, balance bright mill finish; fully baffled. Two, heavy-duty machined 1 1/4" NPT bottom ports, internally diffused. Filler breather assembly includes 40 micron filler breather cap chain mounted with stainless strainer basket and bayonet closure. Dual mounting rails (2" x 2" x 1/4") welded to tank body. Mounting kit includes four, pre-drilled, powder-coated, mounting angles; plated bolts; washers; Nylock nuts; four, plated springs; and four, pre-drilled mounting pads. Mounting kit (ASK-200) is boxed and shipped in the tank assembly carton. Oil and temperature level indicator included. Complete unit is packaged in one carton and shipped via UPS.



A4035-ST shown

Ordering Options	
Product	Product Description
A4035-ST	1 1/4" NPT bottom ports
A4035-2ST	2" NPT bottom ports

TO SEE OUR FULL LINE OF DRAWINGS, GO TO [WWW.AMERICANMOBILEPOWER.COM](http://WWW.AMERICANMOBILEPOWER.COM)

Order No.	Product Weight	Description	Page #
ASK-200	12#	Chassis Mounting Kit	44
ABC-315	1#	Filler Breather Cap Only	46
AFC-330	2#	Fill Assembly	45
ASG-105	1#	Sight/Temperature Gauge	47

**ALL TANKS FACTORY TESTED**

# Model A4070

## Aluminum Upright - 70 Gallon

Tank Size: 50" long x 13" wide x 26" high

Product Weight: 68#

Mounting Kit Weight: 52#

Aluminum assembly; top tank section built of Bright Diamond Plate, balance bright mill finish; fully baffled. Two, heavy-duty machined 1½" NPT bottom ports, internally diffused. Features two, 1" filtered breather vents in tank top for increased air exchange. Filler breather assembly – including 40 micron filler breather cap (chain mounted) with stainless strainer basket and bayonet closure. Base assembly carton includes mounting base, carbon steel strap assembly with springs and rubber pads. Mounting kit includes four, pre-drilled, powder-coated, mounting angles; plated bolts; washers; Nyloc nuts; four, plated springs; and four, pre-drilled mounting pads. Mounting Kit (ASK-200) is boxed and shipped in the base tank assembly carton. Complete unit is packaged in two cartons and shipped via UPS.



*A4070 shown  
Shown with stainless straps upgrade*

### Ordering Options

Product	Product Description
A4070	1½" NPT bottom ports
A4070-ST	1½" NPT bottom ports and Sight Temperature Gauge
* A4070-2	2" NPT bottom ports
* A4070-2ST	2" NPT bottom ports and Sight Temperature Gauge

*\*2" Ports are non-diffused*

TO SEE OUR FULL LINE OF DRAWINGS, GO TO [WWW.AMERICANMOBILEPOWER.COM](http://WWW.AMERICANMOBILEPOWER.COM)

Order No.	Product Weight	Description	Page #
ABA-138	1#	Breather Vent – 1" NPT	46
ASK-200	12#	Chassis Mounting Kit	44
ABC-315	1#	Filler Breather Cap Only	46
AFC-330	2#	Fill Assembly	45
ABK-340-C	52#	Mounting Base Kit Complete	41
AMT-407	66#	Upright Aluminum Tank Only	N/A

**ALL TANKS FACTORY TESTED**

OPTIONS: Available with stainless steel straps

## Model A3500

### Steel Saddlemount - 50 Gallon

Tank Size: 24" diameter x 27" long

Product Weight: 75#

Mounting Kit Weight: 44#

Roll-formed cylindrical steel tank, domed ends are die stamped. Tank powder coated black. Filtered breather vent in tank top for increased air exchange. Filler breather assembly – including 40 micron filler breather cap (chain mounted) with stainless strainer basket and bayonet closure. Three, 1¼" NPT ports with built-in diffusers. Includes one, 1¼" NPT plug. AMK-624-C Mounting kit includes two, frame-mount, rubber shielded, powder-coated, J-brackets and two, rubber-shielded, powder-coated carbon steel strap assemblies. Unit is packaged in one carton and shipped via UPS.



A3500 shown

### Ordering Options

Product	Product Description
A3500	1¼" NPT bottom ports
A3500-ST	1¼" NPT bottom ports and Sight Temperature Gauge
A3500-15	1½" NPT bottom ports
A3500-15ST	1½" NPT bottom ports and Sight Temperature Gauge
* A3500-2	2" NPT bottom ports
* A3500-2ST	2" NPT bottom ports and Sight Temperature Gauge

\*2" Ports are non-diffused

TO SEE OUR FULL LINE OF DRAWINGS, GO TO [WWW.AMERICANMOBILEPOWER.COM](http://WWW.AMERICANMOBILEPOWER.COM)

Order No.	Product Weight	Description	Page #
ABA-138	1#	Breather Vent – ¾" NPT	46
APP-1250	1#	Steel Port Plug – 1¼" NPT	49
ABC-315	1#	Filler Breather Cap Only	46
AFC-330	2#	Fill Assembly	45
AMK-624-C	44#	Carbon Steel Mounting Kit Complete	39
AMT-350	80#	Steel Saddlemount Tank Only (50 Gallons)	N/A

ALL TANKS FACTORY TESTED

OPTIONS: Available with stainless steel straps. Also available with a hose support mount.



# Model A3525

## Steel Saddlemount - 25 Gallon

Tank Size: 24" diameter x 15" long

Product Weight: 55#

Mounting Kit Weight: 44#

Roll-formed cylindrical steel tank, domed ends are die stamped. Tank power coated black. Filler breather assembly – including 40 micron filler breather cap (chain mounted) with stainless strainer basket and bayonet closure. Three, 1¼" NPT ports with built-in diffusers. Includes one, 1¼" NPT plug. AMK-624-C mounting kit includes two, frame-mount, rubber shielded, powder-coated J-brackets and two, rubber-shielded, powder-coated carbon steel strap assemblies. Unit is packaged in one carton and shipped via UPS.



A3525 shown

Ordering Options	
Product	Product Description
A3525	1¼" NPT bottom ports
A3525-ST	1¼" NPT bottom ports and Sight Temperature Gauge
* A3525-2	2" NPT bottom ports
* A3525-2ST	2" NPT bottom ports and Sight Temperature Gauge

\*2" Ports are non-diffused

TO SEE OUR FULL LINE OF DRAWINGS, GO TO [WWW.AMERICANMOBILEPOWER.COM](http://WWW.AMERICANMOBILEPOWER.COM)

Order No.	Product Weight	Description	Page #
AFC-330	2#	Fill Assembly	45
ABC-315	1#	Filler Breather Cap Only	46
APP-1250	1#	Steel Port Plug – 1¼" NPT	49
AMK-624-C	44#	Carbon Steel Mounting Kit Complete	39
AMT-352	57#	Steel Saddlemount Tank Only (25 Gallons)	N/A

**ALL TANKS FACTORY TESTED**

OPTIONS: Available with stainless steel straps. Also available with a hose support mount.

## Model A3535

### Steel Saddlemount - 35 Gallon

Tank Size: 24" diameter x 19" long

Product Weight: 62#

Mounting Kit Weight: 44#

Roll-formed cylindrical steel tank, domed ends are die stamped. Tank power coated black. Filler breather assembly – including 40 micron filler breather cap (chain mounted) with stainless strainer basket and bayonet closure. Three, 1¼" NPT ports with built-in diffusers. Includes one, 1¼" NPT plug. AMK-624-C mounting kit includes two, frame-mount, rubber shielded, powder-coated J-brackets and two, rubber-shielded, powder-coated carbon steel strap assemblies. Unit is packaged in one carton and shipped via UPS.



*A3535 shown*

### Ordering Options

Product	Product Description
A3535	1¼" NPT bottom ports
A3535-ST	1¼" NPT bottom ports and Sight Temperature Gauge
* A3535-2	2" NPT bottom ports
* A3535-2ST	2" NPT bottom ports and Sight Temperature Gauge

*\*2" Ports are non-diffused*

TO SEE OUR FULL LINE OF DRAWINGS, GO TO [WWW.AMERICANMOBILEPOWER.COM](http://WWW.AMERICANMOBILEPOWER.COM)

Order No.	Product Weight	Description	Page #
AFC-330	2#	Fill Assembly	45
ABC-315	1#	Filler Breather Cap Only	46
APP-1250	1#	Steel Port Plug – 1¼" NPT	49
AMK-624-C	44#	Carbon Steel Mounting Kit Complete	39
AMT-352	57#	Steel Saddlemount Tank Only (35 Gallons)	N/A

**ALL TANKS FACTORY TESTED**

**OPTIONS:** Available with stainless steel straps. Also available with a hose support mount.

# Model A3575

## Steel Saddlemount - 75 Gallon

Tank Size: 24" diameter x 39" long

Product Weight: 104#

Mounting Kit Weight: 66#

Roll-formed cylindrical steel tank, domed ends are die stamped; fully baffled. Tank power-coated black. Filtered breather vent in tank top for increased air exchange. Filler breather assembly – including 40 micron filler breather cap (chain mounted) with stainless strainer basket and bayonet closure. Three, 1½" NPT ports with built-in diffusers. Includes one, 1½" NPT plug. AMK-624-C mounting kit includes three, frame-mount, rubber shielded, powder-coated J-brackets and two, rubber-shielded, powder-coated carbon steel strap assemblies. Unit is packaged in two cartons and shipped via UPS.



*A3575 shown*

### Ordering Options

Product	Product Description
A3575	1½" NPT bottom ports
A3575-ST	1½" NPT bottom ports and Sight Temperature Gauge
* A3575-2	2" NPT bottom ports
* A3575-2ST	2" NPT bottom ports and Sight Temperature Gauge

*\*2" Ports are non-diffused*

TO SEE OUR FULL LINE OF DRAWINGS, GO TO [WWW.AMERICANMOBILEPOWER.COM](http://WWW.AMERICANMOBILEPOWER.COM)

Order No.	Product Weight	Description	Page #
ABA-138	1#	Breather Vent – ¾" NPT	46
APP-1250	1#	Steel Port Plug – 1½" NPT	49
ABC-315	1#	Filler Breather Cap Only	46
AFC-330	2#	Fill Assembly	45
AMK-624-C/3	63#	Carbon Steel Mounting Kit Complete (75 Gallons)	40
AMT-357	115#	Steel Saddlemount Tank Only (75 Gallons)	N/A

**ALL TANKS FACTORY TESTED**

**OPTIONS:** Available with stainless steel straps. Also available with a hose support mount.

## Model A35100-ST

### Steel Saddlemount - 100 Gallon

Tank Size: 24" diameter x 51" long

Product Weight: 130#

Mounting Kit Weight: 88#

Roll-formed cylindrical steel tank, domed ends are die stamped; fully baffled. Tank power coated black. Two, filtered breather vents in tank top for increased air exchange. Filler breather assembly – including 40 micron filler breather cap (chain mounted) with stainless strainer basket and bayonet closure. Three, 2" NPT ports. Includes one, 2" NPT plug. Two full baffles, providing a three-compartment tank. AMK-624-C mounting kit includes four, frame-mount, rubber shielded, powder-coated J-brackets and four, rubber-shielded, powder-coated carbon steel strap assemblies. Oil and temperature level indicator included. Unit is packaged in one carton and shipped by truck freight.



TO SEE OUR FULL LINE OF DRAWINGS, GO TO [WWW.AMERICANMOBILEPOWER.COM](http://WWW.AMERICANMOBILEPOWER.COM)

Order No.	Product Weight	Description	Page #
ABA-138	1#	Breather Vent – 3/8" NPT	46
APP-1250	1#	Steel Port Plug – 2" NPT	49
ABC-315	1#	Filler Breather Cap Only	46
AFC-330	2#	Fill Assembly	45
AMK-624-C	44#	Carbon Steel Mounting Kit Complete	39
AMT-351	138#	Steel Saddlemount Tank Only (100 Gallons)	N/A
ASG-105	1#	Sight/Temperature Gauge	47

**ALL TANKS FACTORY TESTED**

**OPTIONS:** Available with stainless steel straps. Also available with a hose support mount.

# Model A4500

## Aluminum Saddlemount - 50 Gallon

Tank Size: 24" diameter x 27" long

Product Weight: 32#

Mounting Kit Weight: 44#

Roll-formed cylindrical aluminum tank, domed ends are die stamped; bright mill finish. Filtered breather vent in tank top for increased air exchange. Filler breather assembly – including 40 micron filler breather cap (chain mounted) with stainless strainer basket and bayonet closure. Three, heavy-duty machined 1¼" NPT ports with built-in diffusers. One, 1¼" NPT port plug included. AMK-624-C mounting kit includes two, frame-mount, rubber shielded, powder-coated J-brackets and two, rubber-shielded, powder-coated carbon steel strap assemblies. Unit is packaged in one carton and shipped via UPS.



*A4500 shown  
Shown with stainless straps upgrade*

### Ordering Options

Product	Product Description
A4500	1¼" NPT bottom ports
A4500-ST	1¼" NPT bottom ports and Sight Temperature Gauge
A4500-15	1½" NPT bottom ports
A4500-15ST	1½" NPT bottom ports and Sight Temperature Gauge
* A4500-2	2" NPT bottom ports
* A4500-2ST	2" NPT bottom ports and Sight Temperature Gauge

*\*2" Ports are non-diffused*

TO SEE OUR FULL LINE OF DRAWINGS, GO TO [WWW.AMERICANMOBILEPOWER.COM](http://WWW.AMERICANMOBILEPOWER.COM)

Order No.	Product Weight	Description	Page #
ABA-138	1#	Breather Vent – ¾" NPT	46
APP-1250	1#	Steel Port Plug – 1¼" NPT	49
ABC-315	1#	Filler Breather Cap Only	46
AFC-330	2#	Fill Assembly	45
AMK-624-C	44#	Carbon Steel Mounting Kit Complete	39
AMT-450	40#	Aluminum Saddlemount Tank Only (50 Gallons)	N/A

**ALL TANKS FACTORY TESTED**

**OPTIONS:** Available with stainless steel straps. Also available with a hose support mount.

## Model A4525

### Aluminum Saddlemount - 25 Gallon

Tank Size: 24" diameter x 15" long

Product Weight: 22#

Mounting Kit Weight 44#

Roll-formed cylindrical aluminum tank, domed ends are die stamped. Bright mill finish. Filler breather assembly – including 40 micron filler breather cap (chain mounted) with stainless strainer basket and bayonet closure. Three, heavy-duty machined 1¼" NPT ports with built-in diffusers. One, 1¼" NPT port plug included. AMK-624-C mounting kit includes two, frame-mount, rubber shielded, powder-coated J-brackets and two, rubber-shielded, powder-coated carbon steel strap assemblies. Unit is packaged in one carton and shipped via UPS.



*A4525 shown  
Shown with stainless straps upgrade*

### Ordering Options

Product	Product Description
A4525	1¼" NPT bottom ports
A4525-ST	1¼" NPT bottom ports and Sight Temperature Gauge
* A4525-2	2" NPT bottom ports
* A4525-2ST	2" NPT bottom ports and Sight Temperature Gauge

*\*2" Ports are non-diffused*

TO SEE OUR FULL LINE OF DRAWINGS, GO TO [WWW.AMERICANMOBILEPOWER.COM](http://WWW.AMERICANMOBILEPOWER.COM)

Order No.	Product Weight	Description	Page #
AFC-330	1#	Fill Assembly	45
ABC-315	1#	Filler Breather Cap Only	46
APP-1250	1#	Steel Port Plug – 1¼" NPT	49
AMK-624-C	2#	Carbon Steel Mounting Kit Complete	39
AMT-452	44#	Aluminum Saddlemount Tank Only (25 Gallons)	N/A

**ALL TANKS FACTORY TESTED**

**OPTIONS:** Available with stainless steel straps. Also available with a hose support mount.

# Model A4535

## Aluminum Saddlemount - 35 Gallon

Tank Size: 24" diameter x 19" long

Product Weight: 26#

Mounting Kit Weight: 44#

Roll-formed cylindrical aluminum tank, domed ends are die stamped; Bright mill finish. Filler breather assembly – including 40 micron filler breather cap (chain mounted) with stainless strainer basket and bayonet closure. Three, heavy-duty machined 1¼" NPT ports with built-in diffusers. One, 1¼" NPT port plug included. AMK-624-C mounting kit includes two, frame-mount, rubber shielded, powder-coated J-brackets and two, rubber-shielded, powder-coated carbon steel strap assemblies. Unit is packaged in one carton and shipped via UPS.



*A4535 shown  
Shown with stainless straps upgrade*

### Ordering Options

<i>Product</i>	<i>Product Description</i>
A4535	1¼" NPT bottom ports
A4535-ST	1¼" NPT bottom ports and Sight Temperature Gauge
* A4535-2	2" NPT bottom ports
* A4535-2ST	2" NPT bottom ports and Sight Temperature Gauge

*\*2" Ports are non-diffused*

TO SEE OUR FULL LINE OF DRAWINGS, GO TO [WWW.AMERICANMOBILEPOWER.COM](http://WWW.AMERICANMOBILEPOWER.COM)

Order No.	Product Weight	Description	Page #
AFC-330	1#	Fill Assembly	45
ABC-315	1#	Filler Breather Cap Only	46
APP-1250	1#	Steel Port Plug – 1¼" NPT	49
AMK-624-C	2#	Carbon Steel Mounting Kit Complete	39
AMT-453	44#	Aluminum Saddlemount Tank Only (35 Gallons)	N/A

**ALL TANKS FACTORY TESTED**

**OPTIONS:** Available with stainless steel straps. Also available with a hose support mount.



## Model A4575

### Aluminum Saddlemount - 75 Gallon

Tank Size: 24" diameter x 39" long

Product Weight: 44#

Mounting Kit Weight: 66#

Roll-formed cylindrical aluminum tank, domed ends are die stamped. Bright mill finish. Filtered breather vent in tank top for increased air exchange. Filler breather assembly – including 40 micron filler breather cap (chain mounted) with stainless strainer basket and bayonet closure. Three, heavy-duty machined 1½" NPT ports with built-in diffusers. One, 1½" NPT port plug included. AMK-624-C mounting kit includes three, frame-mount, rubber shielded, powder-coated J-brackets and three, rubber-shielded, powder-coated carbon steel strap assemblies. Unit is packaged in one carton and shipped via UPS.



**A4575 shown**  
*Shown with stainless straps upgrade*

### Ordering Options

Product	Product Description
A4575	1½" NPT bottom ports
A4575-ST	1½" NPT bottom ports and Sight Temperature Gauge
* A4575-2	2" NPT bottom ports
* A4575-2ST	2" NPT bottom ports and Sight Temperature Gauge

\*2" Ports are non-diffused

TO SEE OUR FULL LINE OF DRAWINGS, GO TO [WWW.AMERICANMOBILEPOWER.COM](http://WWW.AMERICANMOBILEPOWER.COM)

Order No.	Product Weight	Description	Page #
ABA-138	1#	Breather Vent – ¾" NPT	46
APP-1500	1#	Steel Port Plug – 1½" NPT	49
ABC-315	1#	Filler Breather Cap Only	46
AFC-330	2#	Fill Assembly	45
AMK-624-C/3	63#	Carbon Steel Mounting Kit Complete (75 Gallons)	40
AMT-475	55#	Aluminum Saddlemount Tank Only (75 Gallons)	N/A

**ALL TANKS FACTORY TESTED**

**OPTIONS:** Available with stainless steel straps. Also available with a hose support mount.



# Model A45100-ST

## Aluminum Saddlemount - 100 Gallon

Tank Size: 24" diameter x 51" long

Product Weight: 58#

Mounting Kit Weight: 88#

Roll-formed cylindrical aluminum tank, domed ends are die stamped. Bright mill finish. Two, filtered breather vents in tank top for increased air exchange. Filler breather assembly – including 40 micron filler breather cap (chain mounted) with stainless strainer basket and bayonet closure. Three, heavy-duty machined 2" NPT ports. One, 2" port plug included. Two, full baffles, providing a three-compartment tank. Two AMK-624-C mounting kits include four, frame-mount, rubber shielded, powder-coated J-brackets and four, rubber-shielded, powder-coated carbon steel strap assemblies. Oil and temperature level indicator included. Unit is packaged in one carton and shipped by truck freight.



*Shown with stainless straps upgrade*

TO SEE OUR FULL LINE OF DRAWINGS, GO TO [WWW.AMERICANMOBILEPOWER.COM](http://WWW.AMERICANMOBILEPOWER.COM)

Order No.	Product Weight	Description	Page #
ABA-138	1#	Breather Vent – 3/8" NPT	46
APP-2000	1#	Steel Port Plug – 2" NPT	49
ABC-315	1#	Filler Breather Cap Only	46
AFC-330	2#	Fill Assembly	45
AMK-624-C	44#	Carbon Steel Mounting Kit Complete	39
AMT-451	92#	Aluminum Saddlemount Tank Only (100 Gallons)	N/A
ASG-105	1#	Sight/Temperature Gauge	47

**ALL TANKS FACTORY TESTED**

**OPTIONS:** Available with stainless steel straps. Also available with a hose support mount.

## Model A3107

### Steel Sidemount - 7 Gallon

Tank Size: 12" long x 12" wide x 12" high  
 Product Weight: 36#

Steel tank assembly, fully baffled, with 2" x 2" x 6" mounting angles. Two, 1¼" NPT suction ports; two, 1" return line ports; magnetic drain plug; one, 1¼" port plug; and one, 1" port plug. Powder-coated black. Filler breather assembly – including 40 micron filler breather cap (chain mounted) with stainless strainer basket and bayonet closure. Oil level and temperature indicator. Unit is packaged in one carton and shipped via UPS.



TO SEE OUR FULL LINE OF DRAWINGS, GO TO [WWW.AMERICANMOBILEPOWER.COM](http://WWW.AMERICANMOBILEPOWER.COM)

Order No.	Product Weight	Description	Page #
ASG-105	1#	Sight/Temperature Gauge	47
AFC-330	2#	Fill Assembly	45
ABC-315	1#	Filler Breather Cap Only	46
APP-1250	1#	Steel Port Plug – 1¼" NPT	49
APP-0750-M	1#	Magnetic Port Plug – ¾" NPT	49
APP-1000	1#	Steel Port Plug – 1" NPT	49

**ALL TANKS FACTORY TESTED**

**OPTIONS:** Available in aluminum, A4017.

# Model A3100

## Steel Sidemount - 10 Gallon

Tank Size: 12" long x 14" wide x 14" high  
Product Weight: 46#

Steel tank assembly, fully baffled, with pre-punched and slotted 2" x 2" mounting angles. Two, 1/4" NPT suction ports; two, 1" return line ports; magnetic drain plug; one, 1/4" port plug; and one, 1" port plug. Powder-coated black. Filler breather assembly – including 40 micron filler breather cap (chain mounted) with stainless strainer basket and bayonet closure. Oil level and temperature indicator. Unit is packaged in one carton and shipped via UPS.



TO SEE OUR FULL LINE OF DRAWINGS, GO TO [WWW.AMERICANMOBILEPOWER.COM](http://WWW.AMERICANMOBILEPOWER.COM)

Order No.	Product Weight	Description	Page #
ASG-105	1#	Sight/Temperature Gauge	47
AFC-330	2#	Fill Assembly	45
ABC-315	1#	Filler Breather Cap Only	46
APP-1250	1#	Steel Port Plug – 1/4" NPT	49
APP-0750-M	1#	Magnetic Port Plug – 3/4" NPT	49
APP-1000	1#	Steel Port Plug – 1" NPT	49

**ALL TANKS FACTORY TESTED**

**OPTIONS:** Available in aluminum, A4100.

## Model A3150

### Steel Sidemount - 15 Gallon

Tank Size: 16" long x 14" wide x 16" high  
 Product Weight: 60#

Steel tank assembly, fully baffled, with pre-punched and slotted 2" x 2" mounting angles. Two, 2" NPT suction ports; two, 1 1/4" return line ports; magnetic drain plug; one, 1 1/4" port plug; and one, 2" port plug. Powder-coated black. Filler breather assembly – including 40 micron filler breather cap (chain mounted) with stainless strainer basket and bayonet closure. Oil level and temperature indicator. Unit is packaged in one carton and shipped via UPS.



TO SEE OUR FULL LINE OF DRAWINGS, GO TO [WWW.AMERICANMOBILEPOWER.COM](http://WWW.AMERICANMOBILEPOWER.COM)

Order No.	Product Weight	Description	Page #
ASG-105	1#	Sight/Temperature Gauge	47
AFC-330	2#	Fill Assembly	45
ABC-315	1#	Filler Breather Cap Only	46
APP-1250	1#	Steel Port Plug – 1 1/4" NPT	49
APP-0750-M	1#	Magnetic Port Plug – 3/4" NPT	49
APP-2000	1#	Steel Port Plug – 2" NPT	49

**ALL TANKS FACTORY TESTED**

**OPTIONS:** Available in aluminum, A4150, see page 30.

# Model A3250

## Steel Sidemount - 25 Gallon

Tank Size: 20" long x 14<sup>3</sup>/<sub>4</sub>" wide x 20" high  
 Product Weight: 80#

Steel tank assembly, fully baffled, with pre-punched and slotted 2" x 2" mounting angles. Two, 2" NPT suction ports; two, 1<sup>1</sup>/<sub>4</sub>" return line ports; magnetic drain plug; one, 2" port plug; and one, 1<sup>1</sup>/<sub>4</sub>" port plug. Powder-coated black. Filler breather assembly – including 40 micron filler breather cap (chain mounted) with stainless strainer basket and bayonet closure. Oil level and temperature indicator. Unit is packaged in one carton and shipped via UPS.



TO SEE OUR FULL LINE OF DRAWINGS, GO TO [WWW.AMERICANMOBILEPOWER.COM](http://WWW.AMERICANMOBILEPOWER.COM)

Order No.	Product Weight	Description	Page #
ASG-105	1#	Sight/Temperature Gauge	47
AFC-330	2#	Fill Assembly	45
ABC-315	1#	Filler Breather Cap Only	46
APP-1250	1#	Steel Port Plug – 1 <sup>1</sup> / <sub>4</sub> " NPT	49
APP-0750-M	1#	Magnetic Port Plug – 3 <sup>4</sup> / <sub>8</sub> " NPT	49
APP-2000	1#	Steel Port Plug – 2" NPT	49

**ALL TANKS FACTORY TESTED**

**OPTIONS:** Available in aluminum, A4250.

## Model A3300

### Steel Sidemount - 30 Gallon

Tank Size: 24" long x 14<sup>3</sup>/<sub>4</sub>" wide x 20" high  
 Product Weight: 90#

Steel tank assembly, fully baffled, with pre-punched and slotted 2" x 2" mounting angles. Two, 2" NPT suction ports; two, 1<sup>1</sup>/<sub>4</sub>" return line ports; magnetic drain plug; one, 2" port plug; and one, 1<sup>1</sup>/<sub>4</sub>" port plug. Powder-coated black. Filler breather assembly – including 40 micron filler breather cap (chain mounted) with stainless strainer basket and bayonet closure. Oil level and temperature indicator. Unit is packaged in one carton and shipped via UPS.



TO SEE OUR FULL LINE OF DRAWINGS, GO TO [WWW.AMERICANMOBILEPOWER.COM](http://WWW.AMERICANMOBILEPOWER.COM)

Order No.	Product Weight	Description	Page #
ASG-105	1#	Sight/Temperature Gauge	47
AFC-330	2#	Fill Assembly	45
ABC-315	1#	Filler Breather Cap Only	46
APP-1250	1#	Steel Port Plug – 1 <sup>1</sup> / <sub>4</sub> " NPT	49
APP-0750-M	1#	Magnetic Port Plug – <sup>3</sup> / <sub>4</sub> " NPT	49
APP-2000	1#	Steel Port Plug – 2" NPT	49

**ALL TANKS FACTORY TESTED**

**OPTIONS:** Available in aluminum, A4300.

# Model A3400

## Steel Sidemount - 40 Gallon

Tank Size: 32" long x 14<sup>3</sup>/<sub>4</sub>" wide x 20" high  
 Product Weight: 114#

Steel tank assembly, fully baffled, with pre-punched and slotted 2" x 2" mounting angles. Two, 2" NPT suction ports; two, 1<sup>1</sup>/<sub>4</sub>" return line ports; magnetic drain plug; one, 2" port plug; and one, 1<sup>1</sup>/<sub>4</sub>" port plug. Powder-coated black. Filler breather assembly – including 40 micron filler breather cap (chain mounted) with stainless strainer basket and bayonet closure. Oil level and temperature indicator. Unit is packaged in one carton and shipped via UPS.



TO SEE OUR FULL LINE OF DRAWINGS, GO TO [WWW.AMERICANMOBILEPOWER.COM](http://WWW.AMERICANMOBILEPOWER.COM)

Order No.	Product Weight	Description	Page #
ASG-105	1#	Sight/Temperature Gauge	47
AFC-330	2#	Fill Assembly	45
ABC-315	1#	Filler Breather Cap Only	46
APP-1250	1#	Steel Port Plug – 1 <sup>1</sup> / <sub>4</sub> " NPT	49
APP-0750-M	1#	Magnetic Port Plug – <sup>3</sup> / <sub>4</sub> " NPT	49
APP-2000	1#	Steel Port Plug – 2" NPT	49

**ALL TANKS FACTORY TESTED**

## Model A4150

### Aluminum Sidemount - 15 Gallon

Tank Size: 16" long x 14" wide x 16" high  
 Product Weight: 28#

Aluminum tank assembly constructed of Bright Diamond Plate and bright mill finish, fully baffled, with 2" x 2" mounting angles. Two, heavy-duty machined 2" NPT suction ports; two, heavy-duty machined 1 1/4" return line ports; magnetic drain plug; one, 2" port plug; and one, 1 1/4" port plug. Filler breather assembly – including 40 micron filler breather cap (chain mounted) with stainless strainer basket and bayonet closure. Oil level and temperature indicator. Unit is packaged in one carton and shipped via UPS.



TO SEE OUR FULL LINE OF DRAWINGS, GO TO [WWW.AMERICANMOBILEPOWER.COM](http://WWW.AMERICANMOBILEPOWER.COM)

Order No.	Product Weight	Description	Page #
ASG-105	1#	Sight/Temperature Gauge	47
APP-1250	1#	Steel Port Plug – 1 1/4" NPT Fill Assembly	49
APP-2000	1#	Steel Port Plug – 2" NPT	49
ABC-315	1#	Filler Breather Cap Only	46
APP-0750-M	1#	Magnetic Port Plug – 3/4" NPT	49
AFC-330	2#	Fill Assembly	45

ALL TANKS FACTORY TESTED



# Specialty Hydraulic Tanks

## Model A3035-2STRF A3000-2STRF A3070-2STRF

Return Filter\* Style Steel Upright Tank - 35, 50, 70 Gallon  
*\*Return Filter Sold Separately*

Steel Tank Size: See Standard Tank Description

Product Weight: 130#, 134#, 150#

Mounting Kit Weight (for 70 Gallon): 52#

Tanks are fully baffled. Two, 2" NPT bottom ports. Includes Return Filter Support Ring. Filler breather assembly – including 40 micron filler breather cap (chain mounted) with stainless strainer basket and bayonet closure. ASK-200 Mounting and Spring Kit includes four, pre-drilled, powder-coated mounting angles; plated bolts; washers; Nyloc nuts; four, plated springs; and four, pre-drilled mounting pads. Oil and temperature level indicator is included.



## Model A4035-2STRF A4000-2STRF A4070-2STRF

Return Filter\* Style Aluminum Upright Tank - 35, 50, 70 Gallon  
*\*Return Filter Sold Separately*

Tank Size: See Standard Tank Description

Product Weight: 59#, 64#, 72#

Mounting Kit Weight (for 70 Gallon): 52#



## Specialty Hydraulic Tanks

### Model A4535-DS90-ST

Rear Ported Saddlemount Tank - 35 Gallon

Aluminum Tank Size: 24" diameter x 19" long

Product Weight: 30#

Mounting Weight: 44#

Roll-formed cylindrical aluminum tank, domed ends are die stamped. Bright mill finished. Includes one, 2" NPT heavy-duty machined suction port and one, 1¼" heavy-duty machined return line port. Both ports are rear facing for easy and convenient wet line installation and internally separated. Filler breather assembly – including 40 micron filler breather cap (chain mounted) with stainless strainer basket and bayonet closure. Oil level and temperature indicator gauge (can be mounted on either end of tank.) AMK-624-C mounting kit includes two, frame-mounted, rubber shielded, powder-coated J-Brackets and two, rubber-shielded, powder-coated carbon steel strap assemblies. Unit is packaged in one carton and shipped via UPS.



*Shown with stainless straps upgrade*

Also available in steel, A3535-DS90-ST.

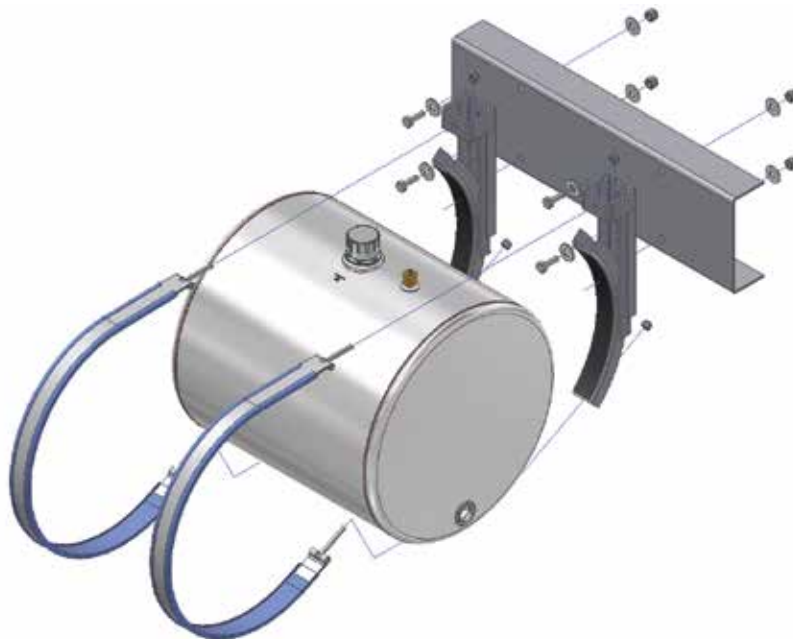

# Specialty Hydraulic Tanks

## Model A4500-2S90-ST

Rear Ported Saddlemount Tank - 50 Gallon

Aluminum Tank Size: 24" diameter x 27" long

Product Weight: 38#

Mounting Kit Weight: 44#

Roll-formed cylindrical aluminum tank, domed ends are die stamped. Bright mill finished. Includes two, 2" NPT heavy-duty machined suction ports. Both ports are rear facing for easy and convenient wet line installation. Filtered mushroom vent in tank top for increased air exchange. Fully baffled, filler breather assembly – including 40 micron filler breather cap (chain mounted) with stainless strainer basket and bayonet closure. Oil level and temperature indicator gauge (can be mounted on either end of tank.) Includes AMK-624-C mounting kit: two, frame-mounted, powder-coated J-Brackets (rubber shielded) and two, rubber-shielded, powder-coated carbon steel strap assemblies. Unit is packaged in one carton and shipped via UPS.



*Shown with stainless straps upgrade*

Also available in 60 gallon.

## Model A3500-2S90-ST

Rear Port Saddlemount Tank - 50 Gallon

Steel Tank Size: 24" diameter x 27" long

Product Weight: 86#

Mounting Kit Weight: 44#

Also available in 60 gallon.



## Specialty Hydraulic Tanks

### Model A3575-2S90-ST

Rear Ported Steel Saddlemount Tank - 75 Gallon

Steel Tank Size: See Standard Tank Description

Product Weight: 106#

Mounting Kit Weight 66#

Roll-formed cylindrical tank, domed ends are die stamped. Filtered mushroom vent in tank top for increased air exchange. Fully baffled, filler breather assembly – including 40 micron filter breather cap (chain mounted) with stainless strainer basket and bayonet closure. Two, 2" rear facing ports for easy and convenient wet line installation. Oil level and temperature indicator gauge (can be mounted on either end of tank). Includes AMK-624-C3 Mounting kit: three frame mounted, powder-coated J-brackets (rubber shielded) and three rubber shielded, powder-coated carbon steel strap assemblies. Unit is packaged in two cartons and shipped by UPS.



Also available in 100 gallon.

### Model A4575-2S90-ST

Rear Ported Aluminum Saddlemount Tank - 75 Gallon

Aluminum Tank Size: See Standard Tank Description

Product Weight: 50#

Mounting Kit Weight 66#

Also available in 100 gallon.



*Shown with stainless straps upgrade*

# Specialty Hydraulic Tanks

## Model A3525-DS90-STRF A3535-DS90-STRF A3500-2S90-STRF

Return Filter\* Rear Ported Steel Saddlemount Tank - 25, 35, 50 Gallon

*\*Return Filter Sold Separately*

Steel Tank Size: See Standard Tank Description

Product Weight: 66#, 70#, 90#

Mounting Kit Weight 44#

Roll-formed cylindrical tank, domed ends are die stamped. Ports are rear facing for easy and convenient wet line installation. Includes Return Filter Support Ring. Filter breather assembly - including 40 micron filter breather cap (chain mounted) with stainless strainer and bayonet closure. Oil level and temperature indicator gauge (can be mounted on either end of tank.) Includes AMK -624-C Mounting kit: two, frame-mounted, powder-coated J-Brackets (rubber shielded) and two rubber shielded, powder-coated carbon steel strap assemblies



## Model A4525-DS90-STRF A4535-DS90-STRF A4500-2S90-STRF

Return Filter\* Rear Ported Aluminum Saddlemount Tank - 25, 35, 50 Gallon

*\*Return Filter Sold Separately*

Aluminum Tank Size: see standard tank description

Product Weight: 30#, 34#, 40#

Mounting Kit Weight 44#



*Shown with stainless straps upgrade*

## Specialty Hydraulic Tanks

**Model A3150-RF**

**A3250-RF**

**A3300-RF**

**A3400-RF**

Return Filter\* Steel Sidemount Tank - 15, 25, 30, 40 Gallon

*\*Return Filter Sold Separately*

Tank Size: See Standard Tank Description

Product Weight: 70#, 90#, 100#, 124#

Steel tank assembly, fully baffled, two NPT suction ports, two return line ports, magnetic drain plug. Includes Return Filter Support Ring. Powder-coated black. Filler breather assembly including 40 micron filter breather cap (chain mounted) with stainless strainer basket and bayonet closure. Oil level and temperature indicator. Unit is packaged in a single carton and shipped by UPS.

Also available in Aluminum, 15, 25 and 30 gallons.



# Specialty Hydraulic Tanks

## Model A320SL

### Slim Line/Space Saving Hydraulic Tank - 20 Gallon

Tank Size: 14 $\frac{3}{4}$ " long x 17 $\frac{1}{4}$ " wide x 20" high

Product Weight: 100#

Steel tank assembly, fully baffled, with pre-punched and slotted 2" x 2" mounting angles. Angles are rear mounted with an extra two, pre-punched and slotted 2" x 2" angles (shipped loose) for adjustable mounting with your specific application. One, 2" NPT suction port; and one, 1 $\frac{1}{4}$ " return line port. Filler breather assembly – including 40 micron filler breather cap (chain mounted) with stainless strainer basket and bayonet closure. Oil level and temperature indicator. Unit is packaged in one carton and shipped via UPS.

Optional return filter (LIT-1250-10P) available upon ordering.  
Also available in 15 gallon



## Model A325SL

### Slim Line/Space Saving Hydraulic Tank - 25 Gallon

Tank Size: 14 $\frac{3}{4}$ " long x 19" wide x 21" high

Product Weight: 110#

Steel tank assembly, fully baffled, with pre-punched and slotted 2" x 2" mounting angles. Angles are rear mounted with an extra two, pre-punched and slotted 2" x 2" angles (shipped loose) for adjustable mounting with your specific application. One, 2" NPT suction port; and one, 1 $\frac{1}{4}$ " return line port. Filler breather assembly – including 40 micron filler breather cap (chain mounted) with stainless strainer basket and bayonet closure. Oil level and temperature indicator. Unit is packaged in one carton and shipped via UPS.

Optional return filter (LIT-1250-10P) available upon ordering.

## Specialty Hydraulic Tanks

### Model A330SL

Slim Line/Space Saving Hydraulic Tank - 30 Gallon

Tank Size: 14<sup>3</sup>/<sub>4</sub>" long x 19" wide x 25" high  
Product Weight: 120#

Steel tank assembly, fully baffled, with pre-punched and slotted 2" x 2" mounting angles. Angles are rear mounted with an extra two, pre-punched and slotted 2" x 2" angles (shipped loose) for adjustable mounting with your specific application. One, 2" NPT suction port; and one, 1<sup>1</sup>/<sub>4</sub>" return line port. Filler breather assembly – including 40 micron filler breather cap (chain mounted) with stainless strainer basket and bayonet closure. Oil level and temperature indicator. Unit is packaged in one carton and shipped via UPS.

Optional return filter (LIT-1250-10P) available upon ordering.  
Also available in 38 gallon

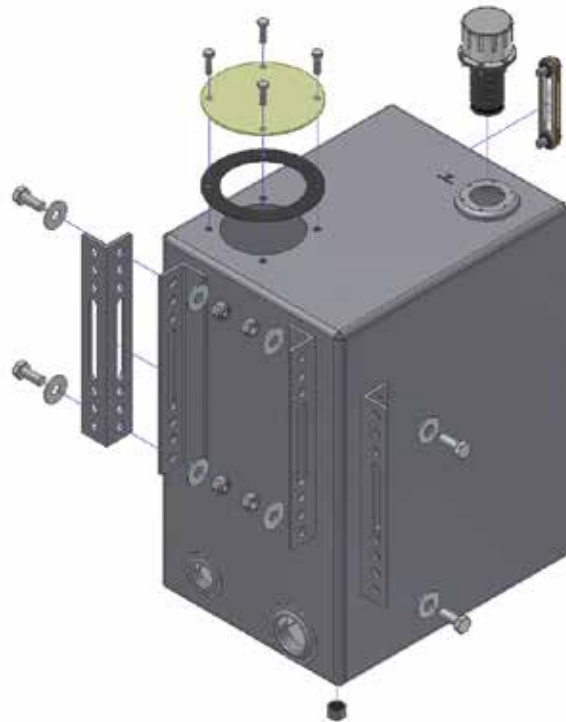



# Hydraulic Mounting Products

## Saddlemount – Mounting Kits

AMK-624-C and AMK-624-S  
For 25, 35, 50 Gallon Saddlemount Tanks  
100 Gallon Saddlemount Tanks Take 2 Kits

### AMK-624-C

Product Weight: 44#

AMK-624-C Carbon Mounting kit is shipped standard with all Steel and Aluminum Saddlemount tanks with a gallon capacity of less than 75 gallon. Mounting kit includes two, frame-mount, rubber shielded, powder-coated, J-brackets and two, rubber-shielded, powder-coated carbon steel strap assemblies. Kit can be purchased separately.

### AMK-624-S

Product Weight: 44#

AMK-624-S Stainless Mounting kit is available as an upgrade option from the standard AMK-624-C. This kit is usable with Saddlemount tanks that are less than 75 gallons. Mounting Kit includes two, frame-mount, rubber shielded, powder-coated, J-brackets and two, rubber-shielded, stainless steel strap assemblies. Kit can be purchased separately.



*AMK-624-S shown*

TO SEE OUR FULL LINE OF DRAWINGS, GO TO [WWW.AMERICANMOBILEPOWER.COM](http://WWW.AMERICANMOBILEPOWER.COM)

Order No.	Product Weight	Description	Page #
AMK-624	16#	“J” Bracket Only	43
ASA-355-C	7#	Carbon Steel Strap Assembly * for AMK-624-C	43
ASA-355-S	5#	Stainless Steel Strap Assembly * for AMK-624-S	43

**ALL TANKS FACTORY TESTED**

NOTE: The 100 Gallon Saddlemount Tanks (A35-100-ST and A45100-ST) are supplied with two of the above kits.

# Hydraulic Mounting Products

## Saddlemount – Mounting Kits

AMK-624-C/3 and AMK-624-S/3  
For 75 Gallon Saddlemount Tanks

AMK-624-C/3  
Carbon Mounting Kit: 75 Gallon  
Product Weight: 66#

AMK-624-C/3 Carbon Mounting Kit is shipped standard with the A3575 and the A4575; 75 gallon capacity Saddlemount Hydraulic Tanks. Mounting kit includes three, frame-mount, rubber shielded, powder-coated, J-brackets and three, rubber-shielded, powder-coated carbon steel strap assemblies. Kit can be purchased separately.



*AMK-624-S/3 shown*

AMK-624-S/3  
Stainless Mounting Kit:  
75 Gallon  
Product Weight: 66#

AMK-624-S Stainless Mounting kit is available as an upgrade option from the standard AMK-624-C. This kit is usable with Saddlemount tanks that are of 75 gallon capacity. Mounting kit includes three, frame-mount, rubber shielded, powder-coated J-brackets and three, rubber-shielded, stainless steel strap assemblies. Kit can be purchased separately.

TO SEE OUR FULL LINE OF DRAWINGS, GO TO [WWW.AMERICANMOBILEPOWER.COM](http://WWW.AMERICANMOBILEPOWER.COM)

Order No.	Product Weight	Description	Page #
AMK-624	16#	“J” Bracket Only	43
ASA-355-C	7#	Carbon Steel Strap Assembly * for AMK-624-C	43
ASA-355-S	5#	Stainless Steel Strap Assembly * for AMK-624-S	43

ALL TANKS FACTORY TESTED

# Hydraulic Mounting Products

## Upright – Mounting Kits

### ABK-340-C Carbon Mounting Kit: 70 Gallon Product Weight: 52#

The ABK-340-C Carbon Mounting Kit comes standard with the A3070 and the A4070 hydraulic upright tanks. Mounting kit includes mounting base panel, rubber-shielded, carbon steel strap assembly with springs. Also supplied is the ASK-200 mounting kit are four, pre-drilled, powder-coated, mounting angles; plated bolts; washers; Nyloc nuts; four, plated springs; and four, rubber mounting pads. Also includes filler breather cap and auxiliary vent. Ships in one carton.



TO SEE OUR FULL LINE OF DRAWINGS, GO TO [WWW.AMERICANMOBILEPOWER.COM](http://WWW.AMERICANMOBILEPOWER.COM)

Order No.	Product Weight	Description	Page #
AMB-405HD	20#	Heavy-duty Mounting Base Panel	43
AMP-205	5#	Rubber Inserts for Heavy-duty Mounting Base Panel	44
ASK-200	12#	Chassis Mounting Kit	44
ASA-355-C	7#	Carbon Steel Strap Assembly (ABK-340-C)	43
ASA-355-S	5#	Stainless Steel Strap Assembly (ABK-340-S)	43

ALL TANKS FACTORY TESTED

# Hydraulic Mounting Products

## Upright – Mounting Kits

### ABK-340-S Stainless Mounting Kit: 70 Gallon Product Weight: 63#

The ABK-340-S Stainless Mounting kit is available as an upgrade option from the ABK-340C. This mounting kit is usable with the 70 gallon upright tanks. Mounting kit includes mounting base panel, stainless steel, rubber-shielded, strap assembly with springs. Also supplied is the ASK-200 mounting kit are four, pre-drilled, powder-coated, mounting angles; plated bolts; washers; Nyloc nuts; four, plated springs; and four, rubber mounting pads. Also includes filler breather cap and auxiliary vent.







TO SEE OUR FULL LINE OF DRAWINGS, GO TO [WWW.AMERICANMOBILEPOWER.COM](http://WWW.AMERICANMOBILEPOWER.COM)

Order No.	Product Weight	Description	Page #
AMB-405HD	20#	Heavy-duty Mounting Base Panel	43
AMP-205	5#	Rubber Inserts for Heavy-duty Mounting Base Panel	44
ASK-200	12#	Chassis Mounting Kit	44
ASA-355-C	7#	Carbon Steel Strap Assembly (ABK-340-C)	43
ASA-355-S	5#	Stainless Steel Strap Assembly (ABK-340-S)	43

ALL TANKS FACTORY TESTED

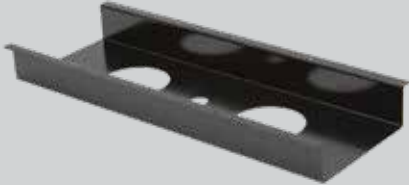
# Hydraulic Mounting Products





TO SEE OUR FULL LINE OF DRAWINGS, GO TO [WWW.AMERICANMOBILEPOWER.COM](http://WWW.AMERICANMOBILEPOWER.COM)

Order No.	Product Weight	Description	
AMB-312	20#	Mounting Base Panel (for A2000 Poly Tank)	
AMB-405HD	20#	Mounting Base Panel – Heavy Duty (for 70 gallon upright)	
AMK-624	14#	“J” Bracket Only	
ASA-355-C	7#	Carbon Steel Strap Assembly Strap Length with T-Bolt – 63" Strap Length without T-Bolt- 57"	
ASA-355-S	5#	Stainless Steel Strap Assembly Strap Length with T-Bolt – 63" Strap Length without T-Bolt- 57"	
AMP-400	1#	Channel Rubber Per foot	



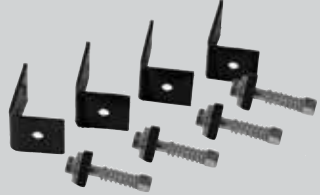







# Hydraulic Mounting Products

TO SEE OUR FULL LINE OF DRAWINGS, GO TO [WWW.AMERICANMOBILEPOWER.COM](http://WWW.AMERICANMOBILEPOWER.COM)

Order No.	Product Weight	Description	
AMP-40053	3#	Channel Rubber (for strap), 53"	
ASK-200	12#	Chassis Mounting Kit	
ASK-210	20#	Heavy-duty Chassis Mounting Kit	
AMP-305	1#	"J" Bracket Rubber	
AMP-205	5#	Rubber Inserts for Heavy-duty Mounting Base Panel	
ASK-200G	12#	Gusseted Mounting Kit, 2.5" x 2.5" x 4"	

# Fill Assembly Products





TO SEE OUR FULL LINE OF DRAWINGS, GO TO [WWW.AMERICANMOBILEPOWER.COM](http://WWW.AMERICANMOBILEPOWER.COM)

Order No.	Product Weight	Description	
FCS-557	1#	Non-vented Cap Assembly	
AFC-330	1#	Fill Cap Assembly, w/out cap	
AFC-350	1#	Fill Cap Assembly	
57XL-10-6DP	1#	Fill Cap Assembly, w/6" Dipstick	
57XL-10-3HN	1#	Fill Cap Assembly, w/3" Riser Cup with 3" Flange	
LC57XL-40N	1#	Lockable Fill Cap Assembly Vented	
57XL-40-5P	2#	Fill Assembly, w/Pressure Cap 5 PSI Breather	
FCS-537W	1#	Filler Cap Assembly Weather Proof	



# Breather Assembly Products

TO SEE OUR FULL LINE OF DRAWINGS, GO TO [WWW.AMERICANMOBILEPOWER.COM](http://WWW.AMERICANMOBILEPOWER.COM)

Order No.	Product Weight	Description	
ABC-315	1#	Filler Breather Cap Only	
ABA-138	1#	<b>Breather Vent, 3/8" NPT</b> Solid steel body, plated cover 60 PSI fully reticulated open core charcoal foam filter	
ABA-12	1#	<b>Breather Vent, 3/4" NPT</b>	
ABA-16	1#	<b>Breather Vent, 1" NPT</b>	



# Hydraulic Tank Parts

TO SEE OUR FULL LINE OF DRAWINGS, GO TO [WWW.AMERICANMOBILEPOWER.COM](http://WWW.AMERICANMOBILEPOWER.COM)

Order No.	Product Weight	Description	
ASG-105	1#	Sight/Temperature Gauge, 5"	
ASG-110	2#	Sight/Temperature Gauge, 10"	
APC-160	2#	Inspection Port Cover, 6"	
APC-160-S	2#	Inspection Stainless Port Cover, 6"	
ADA-250	2#	Diffuser Assembly, 8" Long – 2" to 1¼"	



# Hydraulic Tank Parts

TO SEE OUR FULL LINE OF DRAWINGS, GO TO [WWW.AMERICANMOBILEPOWER.COM](http://WWW.AMERICANMOBILEPOWER.COM)

Order No.	Product Weight	Description	
LIT-1250-10P	6#	In Tank Filter	
LIT-750-10P	6#	In Tank Filter	
LTM-25	2#	Suction Strainer, 2" to 1¼"	
LTM-50	3#	Suction Strainer, 3" to 2"	
LTM-100	3#	Suction Strainer, 3" to 4"	

# Hydraulic Parts

TO SEE OUR FULL LINE OF DRAWINGS, GO TO [WWW.AMERICANMOBILEPOWER.COM](http://WWW.AMERICANMOBILEPOWER.COM)

Order No.	Product Weight	Description
-----------	----------------	-------------

## STEEL WELD FLANGES

AFS-050	1#	Steel Weld Flange, ½"
AFS-075	1#	Steel Weld Flange, ¾"
AFS-100	1#	Steel Weld Flange, 1"
AFS-125	1#	Steel Weld Flange, 1¼"
AFS-150	1#	Steel Weld Flange, 1½"
AFS-200	1#	Steel Weld Flange, 2"
AFS-301	1#	Steel Fill Adapter



## ALUMINUM WELD FLANGES

AFA-038	1#	Aluminum Weld Flange, ⅜"
AFA-050	1#	Aluminum Weld Flange, ½"
AFA-075	1#	Aluminum Weld Flange, ¾"
AFA-100	1#	Aluminum Weld Flange, 1"
AFA-125	1#	Aluminum Weld Flange, 1¼"
AFA-150	1#	Aluminum Weld Flange, 1½"
AFA-200	1#	Aluminum Weld Flange, 2"
AFA-401	1#	Aluminum Fill Adapter

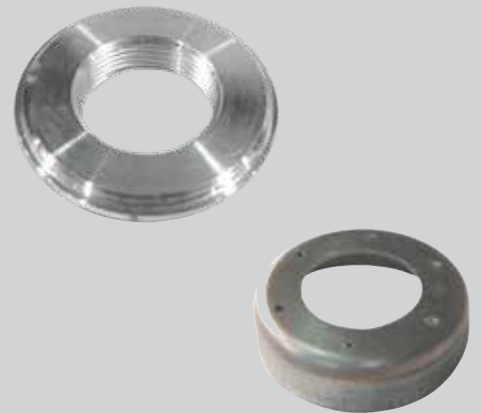

## STEEL PORT PLUGS AND REDUCER BUSHINGS

APP-1000	1#	Steel Port Plug - 1" NPT
APP-1250	1#	Steel Port Plug - 1¼" NPT
APP-1500	1#	Steel Port Plug - 1½" NPT
APP-2000	1#	Steel Port Plug - 2" NPT
APP-0750-M	1#	Magnetic Port Plug - ¾" NPT
ARB-2125	1#	Port Reducer Bushing - plated, 2" x 1¼"



# Hydraulic Accessories

## Wet Line Hose Kits

### 3-Line Systems

#### WL-HK-9-8-3L

9' Pressure/8' Suction  
Product Weight: 24#

#### WL-HK-12-12-3L

12' Pressure/12' Suction  
Product Weight: 32#

#### WL-HK-16-24-3L

16' Pressure/24' Suction  
Product Weight: 40#

#### WL-HK-20-24-3L

20' Pressure/24' Suction  
Product Weight: 44#



TO SEE OUR FULL LINE OF DRAWINGS, GO TO [WWW.AMERICANMOBILEPOWER.COM](http://WWW.AMERICANMOBILEPOWER.COM)

Order No.	Product Weight	Description	Qty./Kit	Page #
AQD-1010	5#	1" Quick Disconnect – Complete	1 each	53
AHB-125	1#	1¼" NPT Male Hose Barb	4 each	N/A
AHC-150	1#	Hose Clamp Wormdrive	4 each	N/A
APH-1	2#	1" SAE 100 R17 Pressure Hose	ft. – see kit	N/A
ASH-125	2#	1¼" SAE 100 R4 Suction Hose	ft. – see kit	N/A

# Hydraulic Accessories

## Wet Line Hose Kits

### 2-Line Systems

#### **WL-HK-12-6-2L**

12' Pressure/6' Suction  
Product Weight: 22#

#### **WL-HK-14-8-2L**

14' Pressure/8' Suction  
Product Weight: 26#

#### **WL-HK-16-8-2L**

16' Pressure/8' Suction  
Product Weight: 30#

#### **WL-HK-20-12-2L**

20' Pressure/12' Suction  
Product Weight: 34#



*WL-HK-14-8-2L shown*

TO SEE OUR FULL LINE OF DRAWINGS, GO TO [WWW.AMERICANMOBILEPOWER.COM](http://WWW.AMERICANMOBILEPOWER.COM)

Order No.	Product Weight	Description	Qty./Kit	Page #
AQD-1010	5#	1" Quick Disconnect – Complete	1 each	53
AHB-125	1#	1¼" NPT Male Hose Barb	2 each	N/A
AHC-150	1#	Hose Clamp Wormdrive	2 each	N/A
APH-1	2#	1" SAE 100 R17 Pressure Hose	ft. – see kit	N/A
ASH-125	2#	1¼" SAE 100 R4 Suction Hose	ft. – see kit	N/A

## Hydraulic Accessories Hose Support Kits

### AHS-125

For use with 1¼" hose application

Product Weight: 5#

### AHS-150

For use with 1½" hose application

Product Weight: 7#

### AHS-200

For use with 2" hose application

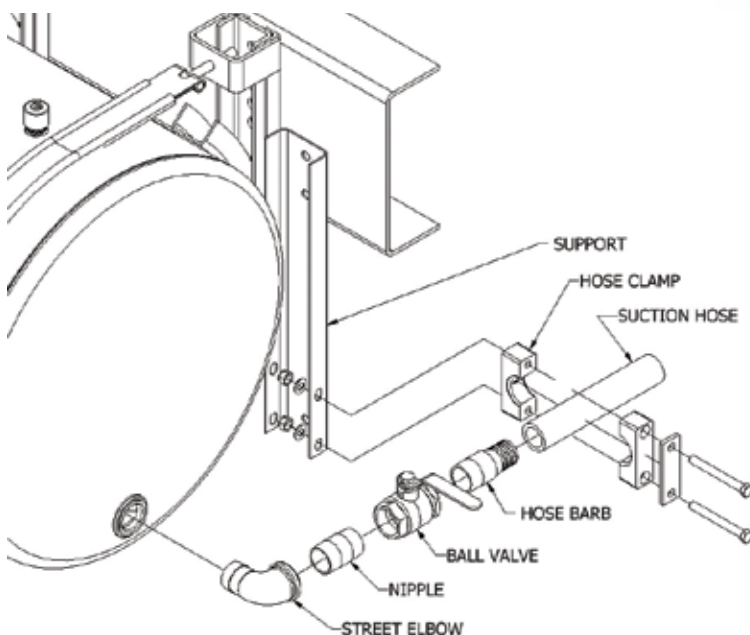

Product Weight: 9#

- Prevents stress on ports
- Precision clamps – designed for hydraulic hose diameters
- Left or right applications
- Mounting bracket pre-punched



# Hydraulic Accessory Parts

TO SEE OUR FULL LINE OF DRAWINGS, GO TO [WWW.AMERICANMOBILEPOWER.COM](http://WWW.AMERICANMOBILEPOWER.COM)

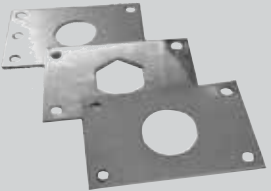
Order No.	Product Weight	Description	
AQD-1010	5#	Quick Disconnect – Complete, 1"	
AQM-1010	2#	Male Coupler End, 1"	
AQF-1010	2#	Female Coupler End, 1"	
ARM-1010	1#	Rapid Mount Assembly	
LPBV-20	1#	Low Pressure Ball Valve, 1 1/4"	

# American Transfer Tank System

## Model ATT4070

Aluminum Upright - 70 Gallon

Tank Size: 50.16" long x 13" wide x 26" high

Product Weight: 74#

Total aluminum construction; top tank section built of Bright Diamond Plate, balance is mill finish; fully baffled; two, 2" machined hex stock NPT ports in top ends of tank to accommodate transfer pump and/or vented cap, ports are internally reinforced. 2" NPT lockable vented cap provided; four, 4" long 2" x 2" angles welded in place for secure deck mounting; 3/4" NPT drain port with plug located at bottom edge of left head. Ships by truck freight.



Also available in Aluminum Upright 50 gallon – ATT4050  
 Aluminum Upright 90 gallon – ATT4090  
 Steel Upright 50 gallon – ATT3050  
 Steel Upright 70 gallon – ATT3070  
 Steel Upright 90 gallon – ATT3090

TO SEE OUR FULL LINE OF DRAWINGS, GO TO [WWW.AMERICANMOBILEPOWER.COM](http://WWW.AMERICANMOBILEPOWER.COM)

Order No.	Product Weight	Description	Page #
APP-0750-M	1#	Magnetic Port Plug – 3/4" NPT	58
906001-4	1#	2" NPT Vented Cap	59

**ALL FACTORY TESTED**

It is the users responsibility to comply with local, state, and federal requirements. Tanks are intended for use with non-hazardous fluids and fluids with a flash point greater than 100 deg. F.

**NOTE:** Transfer tanks must not be connected to a vehicle fuel system as an auxiliary fuel tank.



# American Transfer Tank System

## Model ATT4072

Aluminum Deck Mount - 72 Gallon

Tank Size: 42" long x 20" wide x 20" high

Product Weight: 74#

Total aluminum construction; top, front and back sides built of Bright Diamond Plate, balance is mill finish; fully baffled; two, 2" machined hex stock NPT ports in top ends of tank to accommodate transfer pump and/or vented cap, ports are internally reinforced. 2" NPT lockable vented cap provided; two, 12" long 2" x 2" angles welded to ends of tank for secure deck mounting; 3/4" NPT drain port with plug located at bottom edge of left head. Ships by truck freight.



Also available in Aluminum 102 gallon – ATT41020

Steel 72 gallon – ATT3072

TO SEE OUR FULL LINE OF DRAWINGS, GO TO [WWW.AMERICANMOBILEPOWER.COM](http://WWW.AMERICANMOBILEPOWER.COM)

Order No.	Product Weight	Description	Page #
APP-0750-M	1#	Magnetic Port Plug – 3/4" NPT	58
906001-4	1#	2" NPT Vented Cap	59

**ALL FACTORY TESTED**

It is the users responsibility to comply with local, state, and federal requirements. Tanks are intended for use with non-hazardous fluids and fluids with a flash point greater than 100 deg. F.

**NOTE:** Transfer tanks must not be connected to a vehicle fuel system as an auxiliary fuel tank.

# American Transfer Tank System Model ATT4075

Aluminum "L" Style - 75 Gallon

Tank Size: 48" long x Leg – 18" high x 10" deep; Foot – 9" high x 30" deep

**Designed for full size, short bed, club cab pickups.**

Product Weight: 90#

**Features:** Low profile height  
All bright tread finish  
75 Gallon Capacity



Total aluminum construction; all exposed surfaces built of Bright Diamond Plate; dual built-in baffles; two, 2" machined hex stock NPT ports in top ends of tank to accommodate transfer pump and/or vented cap, ports are internally reinforced. 2" NPT lockable vented cap provided; four, 6" long 2" x 2" angles welded in place for secure deck mounting; 3/4" NPT drain port with plug located at bottom edge of left head. Ships by truck freight.

Also available in Aluminum 100 gallon – ATT4088  
Aluminum 120 gallon – ATT41120

TO SEE OUR FULL LINE OF DRAWINGS, GO TO [WWW.AMERICANMOBILEPOWER.COM](http://WWW.AMERICANMOBILEPOWER.COM)

Order No.	Product Weight	Description	Page #
APP-0750-M	1#	Magnetic Port Plug – 3/4" NPT	58
906001-4	1#	2" NPT Vented Cap	59

**ALL FACTORY TESTED**

It is the users responsibility to comply with local, state, and federal requirements. Tanks are intended for use with non-hazardous fluids and fluids with a flash point greater than 100 deg. F.

**NOTE:** Transfer tanks must not be connected to a vehicle fuel system as an auxiliary fuel tank.

# Transfer Pumps

TO SEE OUR FULL LINE OF DRAWINGS, GO TO [WWW.AMERICANMOBILEPOWER.COM](http://WWW.AMERICANMOBILEPOWER.COM)

Order No.	Product Weight	Description
HP-100	14#	<p><b>Petroleum Hand Pump</b></p> <p>The Hand Pump is compatible with a wide variety of petroleum products and fits any container with a 2" NPT bung and tapered threads. Lightweight, die-cast aluminum housing. Stainless steel piston shaft and liner. Built-in, anti-siphon valve to prevent leaks.</p> <ul style="list-style-type: none"><li>• Pumping Capacity: Up to ½ gallon or 1.9 liters/stroke cycle.<ul style="list-style-type: none"><li>▪ ½ gallon setting for high volume, high resistance;</li><li>▪ ¼ gallon setting for low volume, low resistance.</li></ul></li><li>• Inlet: 1" NPT Outlet: ¾" NPT</li><li>• Hose: ¾" x 8 ft. Dry Prime: 5 ft. minimum</li><li>• Nozzle: Thermoplastic unleaded nozzle. Built-in nozzle holder.</li><li>• Suction Pipe: Plastic, adjustable 22 to 40 inches</li><li>• Security: Handle can be padlocked.</li></ul>
M-150	23#	<p><b>Standard Volt Electric Pump</b></p> <p>Application for low viscosity petroleum fuels such as gasoline, kerosene, and diesel fuel. Outdoor, year-round operating use with a temperature range of -20° to +125° F. Designed for mounting on portable, vented storage tanks. Lightweight, corrosion-resistant, cast aluminum body. Convenient spin collar for easy installation.</p> <ul style="list-style-type: none"><li>• Pump Rate: Up to 15 GPM</li><li>• Duty Cycle: 30 min. on/30 min. off</li><li>• Input: 12 volt DC Motor: 1900 rpm Motor</li><li>• Protector: 20 amps</li><li>• Cord: 15 ft. of 12 gauge</li><li>• Bung: 2" NPT</li><li>• Inlet: 1" NPT</li><li>• Outlet: ¾" NPT</li><li>• Hose: ¾" x 12 ft. Buna-N</li><li>• Suction: Plastic, adjustable 22 to 40 inches</li><li>• Security: Nozzle can be padlocked. Also available with automatic shutoff.</li></ul>



# Transfer Accessories and Parts

TO SEE OUR FULL LINE OF DRAWINGS, GO TO [WWW.AMERICANMOBILEPOWER.COM](http://WWW.AMERICANMOBILEPOWER.COM)

Order No.	Product Weight	Description
-----------	----------------	-------------

01A3AGM

1#

**Electric Digital Fuel Meter**

Designed for outdoor, year-round use on fuel transfer pumps in the 3 to 30 GPM (10 to 100 LPM) flow range. Calibrated at the factory for use with gasoline, diesel fuel or kerosene. Requires two AA batteries that can easily be replaced by the user. Approximate battery life is 9,000 hours. Installs easily to the above Electric pump, M-150, for maximum efficiency.



APP-0750-M

1#

**Magnetic Port Plug, 3/4" NPT**



TO SEE OUR FULL LINE OF DRAWINGS, GO TO [WWW.AMERICANMOBILEPOWER.COM](http://WWW.AMERICANMOBILEPOWER.COM)

Order No.	Product Weight	Description
906001-4	1#	NPT Vented Cap, 2"

The image shows a 2-inch NPT vented cap assembly. It includes a circular metal cap with a vented top, a main vented cap body with a flange, and a small metal O-ring. Below the cap assembly are two identical rectangular labels with a red border. Each label features a red flame icon, the text "COMBUSTIBLE" in a large font, "DIESEL FUEL" in a smaller font below it, and a small red number "2" in the bottom right corner.

ATT-200

Transfer Mounting Bracket



# 22" Aluminum Reefer Tank

Original Equipment Replacement; Mounting Kit Not Included

## AR2235

35 Gallon Capacity, 22" diameter x 27" long  
Product Weight: 27#

## AR2250

50 Gallon Capacity, 22" diameter x 33" long  
Product Weight: 34#

## AR2275

75 Gallon Capacity, 22" diameter x 51" long  
Product Weight: 50#

## AR22100

100 Gallon Capacity, 22" diameter x 61" long  
Product Weight: 62#



TO SEE OUR FULL LINE OF DRAWINGS, GO TO [WWW.AMERICANMOBILEPOWER.COM](http://WWW.AMERICANMOBILEPOWER.COM)

Order No.	Product Weight	Description	Page #
FGA-2200	2#	Fuel Float Gauge	64
PRT-2200	1#	Pick-up/Return Tube, 1/2" NPT x 1/4" NPT	64
FNC-2000	2#	2" Female Non-vented Cap	64
ASV-0500	2#	1/2" NPT Anit-spill Vent	64
BCV-0500	1#	Bottom/Check Valve, Drain and Plug – 1/2" NPT	65

# 24" Aluminum Reefer Tank

Mounting Kit Included

## AR8535

35 Gallon Capacity, 24" diameter x 23" long  
Product Weight: 30# – Mounting Kit Weight 44#

## AR8550

50 Gallon Capacity, 24" diameter x 27" long  
Product Weight: 35# – Mounting Kit Weight 46#

## AR8575

75 Gallon Capacity, 24" diameter x 39" long  
Product Weight: 40# – Mounting Kit Weight 66#

## AR85100

100 Gallon Capacity, 24" diameter x 58" long  
Product Weight: 50# – Mounting Kit Weight 66#



24" diameter, rolled aluminum cylinder; domed ends are die stamped with front head recessed to accept bolt on fuel gauge; metal is mill finished; fill assembly includes chain-mounted, non-vented screw on cap; three, 1/2" NPT top ports to accept the anti-spill vent; two, 1/2" x 1/4" pick up and return line tubes; rectangular bottom mounted sump includes shielded brass drain check plug assembly. Unit is packaged and shipped via UPS. Unit meets all FHWA side mounted fuel tank requirements. Units are designed for use with "Diesel Fuel Only".

TO SEE OUR FULL LINE OF DRAWINGS, GO TO [WWW.AMERICANMOBILEPOWER.COM](http://WWW.AMERICANMOBILEPOWER.COM)

Order No.	Product Weight	Description	Page #
FGA-2200	2#	Fuel Float Gauge	64
PRT-2200	1#	Pick-up/Return Tube, 1/2" NPT x 1/4" NPT	64
FNC-2000	2#	2" Female Non-vented Cap	64
ASV-0500	2#	1/2" NPT Anit-spill Vent	64
BCV-0500	1#	Bottom/Check Valve, Drain and Plug – 1/2" NPT	65

# Reefer Mounting Products

## Reefer Heavy-duty Mounting Kits

### RMK-822-S

For Installation of 22" Reefer Tank  
Mounting Kit Carton: 44#

PRE-PACKAGED KIT INCLUDES:  
Heavy-duty Mounting Kit

- This kit includes:
- (2) Heavy-duty Brackets (RMK-824)
  - (2) Stainless Steel Straps (ASA-5852S)
  - (2) Frame Mounting Hardware (ASK-205-R)



### RMK-824-S

For installation of 24" Reefer Tank  
Mounting Kit Carton: 44#

PRE-PACKAGED KIT INCLUDES:  
Heavy-duty Mounting Kit

- This kit includes:
- (2) Heavy-duty Brackets (RMK-824)
  - (2) Stainless Steel Straps (ASA-6357S)
  - (2) Frame Mounting Hardware (ASK-205-R)



TO SEE OUR FULL LINE OF DRAWINGS, GO TO [WWW.AMERICANMOBILEPOWER.COM](http://WWW.AMERICANMOBILEPOWER.COM)

Order No.	Product Weight	Description	Page #
RMK-824	12#	Heavy-duty Cradle Brackets (Radius is rubber lined)	65
ASA-5852S	5#	Stainless Steel Strap Complete w/Nyloc Nuts, 22" Tank	65
ASA-6357S	5#	Stainless Steel Strap Complete w/Nyloc Nuts, 24" Tank	65
ASK-205-R	3#	Frame Mounting Hardware	65



# Reefer Mounting Products

## Reefer Heavy-duty Mounting Kits

### RMK-822-S/3

For Installation of 75 Gallon 22" Reefer Tank  
Mounting Kit Carton: 66#

PRE-PACKAGED KIT INCLUDES:  
Heavy-duty Mounting Kit

This kit includes:

- (3) Heavy-duty Brackets (RMK-824)
- (3) Stainless Steel Straps (ASA-5852S)
- (3) Frame Mounting Hardware (ASK-205-R)



### RMK-824-S/3

For Installation of 75 Gallon 24" Reefer Tank  
Mounting Kit Carton: 66#

PRE-PACKAGED KIT INCLUDES:  
Heavy-duty Mounting Kit

This kit includes:

- (3) Heavy-duty Brackets (RMK-824)
- (3) Stainless Steel Straps (ASA-6357S)
- (3) Frame Mounting Hardware (ASK-205-R)







TO SEE OUR FULL LINE OF DRAWINGS, GO TO [WWW.AMERICANMOBILEPOWER.COM](http://WWW.AMERICANMOBILEPOWER.COM)

Order No.	Product Weight	Description	Page #
RMK-824	12#	Heavy-duty Cradle Brackets (Radius is rubber lined)	65
ASA-5852S	5#	Stainless Steel Strap Complete w/Nyloc Nuts, 22" Tank	65
ASA-6357S	5#	Stainless Steel Strap Complete w/Nyloc Nuts, 24" Tank	65
ASK-205-R	3#	Frame Mounting Hardware	65

# Reefer Assembly Products

TO SEE OUR FULL LINE OF DRAWINGS, GO TO [WWW.AMERICANMOBILEPOWER.COM](http://WWW.AMERICANMOBILEPOWER.COM)

Order No.	Product Weight	Description	
FGA-2200	2#	Fuel Float Gauge	
PRT-2200	1#	Pick-up/Return Tube, 22" Tank, 1/2" NPT x 1/4" NPT	
PRT-2400	1#	Pick-up Return Tube, 24" Tank, 1/2" NPT x 1/4" NPT	
FNC-2000	2#	Female Non-vented Cap, 2"	
ASV-0500	2#	NPT Anti-spill Vent, 1/2"	

# Reefer Assembly Products

Continued

TO SEE OUR FULL LINE OF DRAWINGS, GO TO [WWW.AMERICANMOBILEPOWER.COM](http://WWW.AMERICANMOBILEPOWER.COM)

Order No.	Product Weight	Description
-----------	----------------	-------------

BCV-0500

1#

**Bottom Check Valve,  
Drain and Plug – ½" NPT**



RMK-824

12#

**Heavy-duty Cradle Brackets  
(Radius is rubber lined)**



ASA-5852S

12#

**Stainless Steel Strap Complete**

Use Part No. ASA-5852S-22" Tank

ASA-6357S

Use Part No. ASA-6357S-24" Tank



ASK-205-R

9#

**Frame Mounting Hardware**



FNC-2000-LC

2#

**Female Non-vented Locking Cap, 2"**



## American Wet Tank System

### Model A2000

Gross Dimensional Capacity: 50 Gallons

#### Mounting Kit Contents: Part Number ASK-2000

Qty	Description
4	Pre-drilled and powder-coated chassis mounting angles
4	Pre-drilled rubber mounting pads
4	Two inch (2") plated compression springs
4	Cap screws - $\frac{5}{8}$ " - 11 x 3 $\frac{1}{2}$ ", grade 5
4	Nyloc nuts - $\frac{5}{8}$ " - 11
8	Plated flat washers - $\frac{5}{8}$ "

#### Materials Required to Complete Installation:

Qty	Description
8	Cap screws $\frac{1}{2}$ ", grade 5 (length determined by installer)
8	Nyloc Nuts - $\frac{1}{2}$ " - 13
16	$\frac{1}{2}$ " washers

#### Pre-packaged Kit Includes:

Polyethylene tank assembly with two, 2" NPT bottom ports, the tank itself is factory mounted and secured to the pre-drilled mounting base with six bolts and Nyloc nuts. A compression nut is torqued against the bottom of the base. Do NOT remove torqued nuts. The kit also includes a screw-in diffuser; a sight-temperature gauge (mounted 5" on center); 2" to 1 $\frac{1}{4}$ " plated reducer bushing; and the ASK-200 mounting kit.

This wet tank assembly has been designed for an end dump trailer application using either a two- or three-line system.

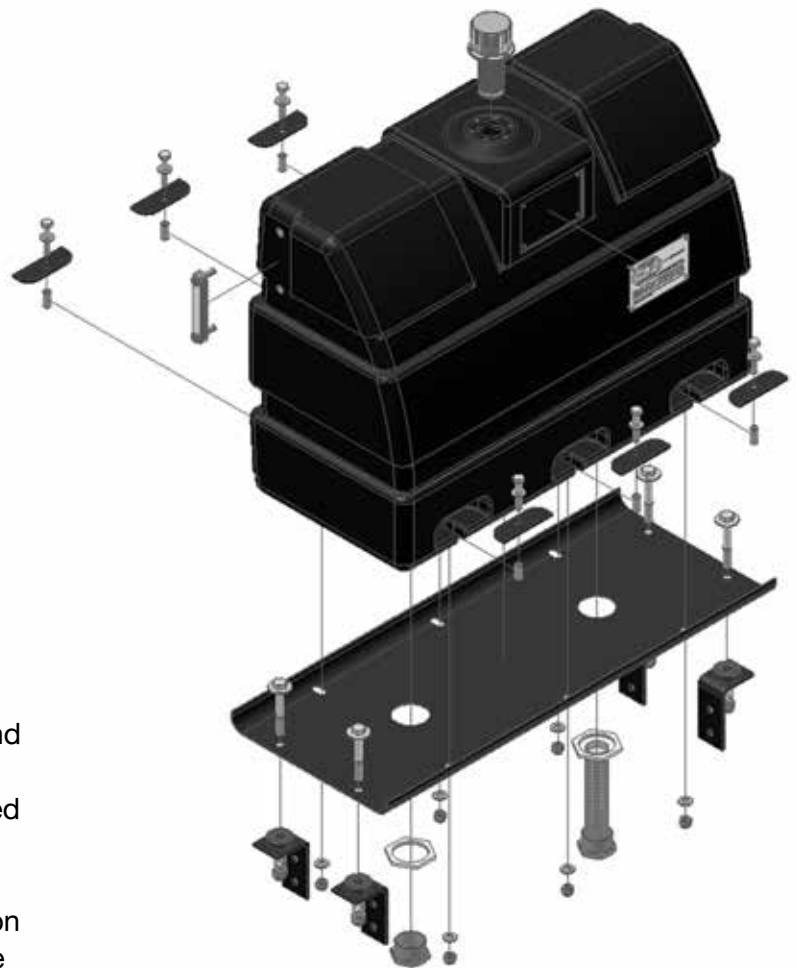

**WARNING:** MAXIMUM HYDRAULIC CYCLE TIME MUST NOT EXCEED 5 MINUTES. LONGER RUNNING TIME MAY RESULT IN EXCESSIVE HEAT BUILDUP AND SUBSEQUENT DAMAGE.

OPERATING TEMPERATURE: DO NOT EXCEED 180°F

# American Wet Tank System Model A2000

**Instructions:**

1. Position tank and base assembly on frame rails of the truck chassis as desired.
2. Position chassis mounting angles so that the double pre-drilled holes are positioned against the frame rail and the single (1<sup>1</sup>/<sub>16</sub>" hole is positioned upward against the mounting base. *(See diagram at right.)*  
*Note: The top of the mounting angle should be flush with the top of the chassis rail as shown.*
3. Using the pre-drilled mounting angles as a guide, mark both the frame rail and tank mounting angles. Chassis requires use of a 9/16" drill bit while the mounting base requires an 1<sup>1</sup>/<sub>16</sub>" drill bit. Drill holes and bolt the four mounting angles into place.

**Note: The rubber pads should be above the top of the frame rails. (See diagram at right.)**

**4. NATIONAL PIPE THREAD PORT OPENINGS:**

The American Wet Tank System is designed with two, 2" NPT metal port openings in the bottom of the tank. Each fitting is molded securely in the tanks and features an exterior mounted compression nut. These nuts are torqued to tolerance at the factory and **MUST NOT BE DISTURBED**. The system allows either port to be used as a suction or return line. Further, the assembly may be plumbed for use as a two-line or three-line system. *(See diagram at right.)*

5. **DIFFUSER INSTALLATION:** Simply remove diffuser unit from packaging, seal threads using standard pipe dope only, and screw into port of your selection. Tighten fitting into place **USING CARE NOT TO OVER TIGHTEN**. *(See diagram at right.)*

**Note: Installed diffuser provides 1<sup>1</sup>/<sub>4</sub>" NPT opening to accommodate hose connection.**

6. **REDUCER BUSING:** is provided for the second port (2" to 1<sup>1</sup>/<sub>4</sub>"). Again, using standard pipe dope on threads and taking caution not to over tighten. This port is ready for hose connection if using a three-line system or may be plugged if a two-line system is desired. *(See diagram at right.)*

**Note: Use torque required to seat either diffuser or reducer bushing. Taking care not to overtighten.**



# INSTALLATION

7. Install pre-assembled tank and mounting base: secure with  $\frac{5}{8}$ " x 4 $\frac{1}{2}$ " cap screws, washers, springs and lock nuts as supplied in mounting kit.  
(ASK-200) (See main diagram.)

**Note:** Tighten the  $\frac{5}{8}$ " locknuts until the compressed length of the spring is 1 $\frac{1}{2}$ " (See diagram at right.)

## DO NOT COMPRESS SPRINGS COMPLETELY

8. **FILL CAP:** Remove filter/breather cap from its carton; re-connect chain and mount in bayonet style closure. Maximum fill is 2" below bayonet closure.

**Note:** Filter/breather cap should be periodically cleaned or replaced to prevent plugging and possible system damage.

9. Install Notices In-Cab

You are now ready to begin plumbing the system of your choice.



## TANK LABELING



These Labels are installed on the tank by the manufacturer.

## IN-CAB NOTICE



### INSTALLER:

Metal "Notice" Label must be placed in-cab. Peel backing and press onto a prominent in-cab location.

# American Wet Tank System

## Models: A3500 and A4500

Also Includes: A3525, A3535, A3575, A35100-ST  
A4525, A4535, A4575, A45100-ST

### A3575 – A4575

75 Gallon Units

Requires Three Bracket Assemblies

Use Kit Number:

AMK-624-C/3 (Carbon Steel)

AMK-624-S/3 (Stainless)

### A35100-ST – A45100-ST

100 Gallon Units

Requires Four Bracket Assemblies

Use 2 of the following:

AMK-624-C (Carbon Steel)

AMK-624-S (Stainless)

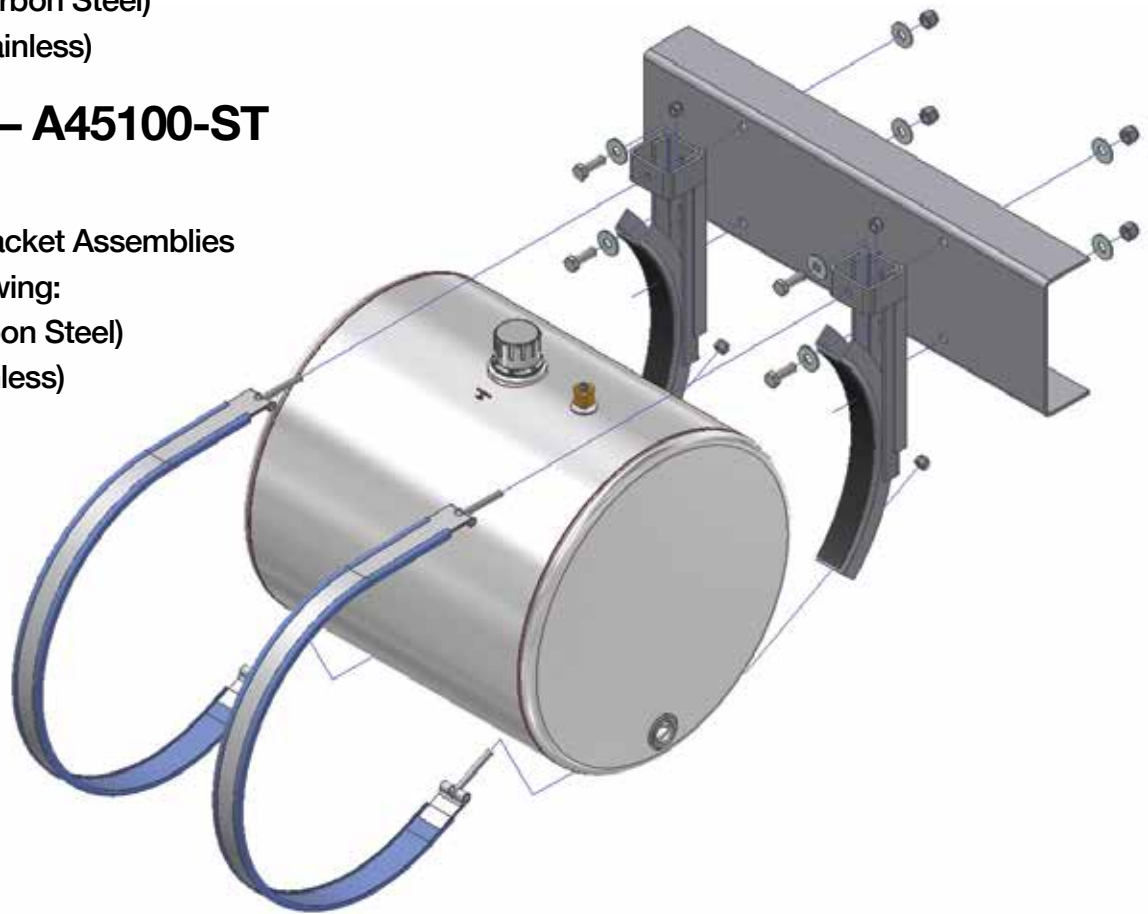

# American Wet Tank System

## Models: A3500 and A4500

**Mounting Kit Contents: Part Number AMK-624-C (carbon steel)**  
**Part Number AMK-624-S (stainless steel)**

Qty	Description
2	"J" brackets – powder coted, radius is rubber lined (affixed)
2	2" wide strap assemblies including four Nyloc nuts

### **Materials Required to Complete Installation:**

Qty	Description
4	5/8" – grade 5 bolts (length determined by installer)
4	Nyloc Nuts – 5/8" - 11
8	5/8" washers

### **Pre-packaged Kit Includes:**

Steel or aluminum tank assembly (25 gallon through 100 gallon) with three, 1¼" NPT ports (75 gallon have 1½" NPT ports), (100 gallon have 2" NPT ports), the 50 gallon and larger units include auxiliary breather vent in tank for increased air exchange; each is provided with a filler breather assembly including 40 micron filter breather cap (chain mounted) with nylon strainer basket and bayonet closure; all ports in each unit are internally diffused (except 100 gallon); one port plug provided; all steel parts are powder-coated black; saddle mount bracket and strap assemblies are rubber shielded.

### **Instructions:**

1. Position the top of the cradle bracket flush with the truck frame rail.
2. Attach brackets to frame rail with at least (2) 5/8", grade 5 bolts (per bracket).

***Note: Brackets should be placed within 2" from ends of tank, 75 gallon tanks require and extra bracket (and strap) placed on either side of the fill cap, at least ½" from weld. 100 gallon tanks require two extra brackets (and straps), spaced evenly and at least ½" from weld.***

3. Place tank against brackets and firmly tighten nuts to straps (not more than 25 ft.lbs. of torque).
4. Install plumbing. All plumbing and fitting connections attached to tanks must be properly supported into same moving plane as the tank in order to keep plumbing and fittings from creating a metal fatigue fracture outside of port weld. We suggest using a hose support mount (which we offer).

***Note: Filter/breather cap should be periodically cleaned or replaced to prevent plugging and possible system damage.***



# American Wet Tank System

## Models: A3000 and A4000

### Mounting Kit Contents: Part Number ASK-200

Qty	Description
4	Pre-drilled and powder-coated chassis mounting angles
4	Pre-drilled rubber mounting pads
4	Two inch (2") plated compression springs
4	Cap screws - $\frac{5}{8}$ " - 11 x 4 $\frac{1}{2}$ ", grade 5
4	Nyloc nuts - $\frac{5}{8}$ " - 11
8	Plated flat washers - $\frac{5}{8}$ "

### Materials Required to Complete Installation:

Qty	Description
8	Cap screws $\frac{1}{2}$ ", grade 5 (length determined by installer)
8	Nyloc Nuts - $\frac{1}{2}$ " - 13
16	$\frac{1}{2}$ " washers

### Pre-packaged Kit Includes:

Steel or aluminum tank assembly with two, 1 $\frac{1}{4}$ " screw-in NPT bottom ports; filler breather assembly including a 40 micron filter breather cap (chain mounted); auxiliary vent; and the ASK-200 mounting kit.

This wet tank assembly has been designed for a dump trailer application using either a two- or three-line system.

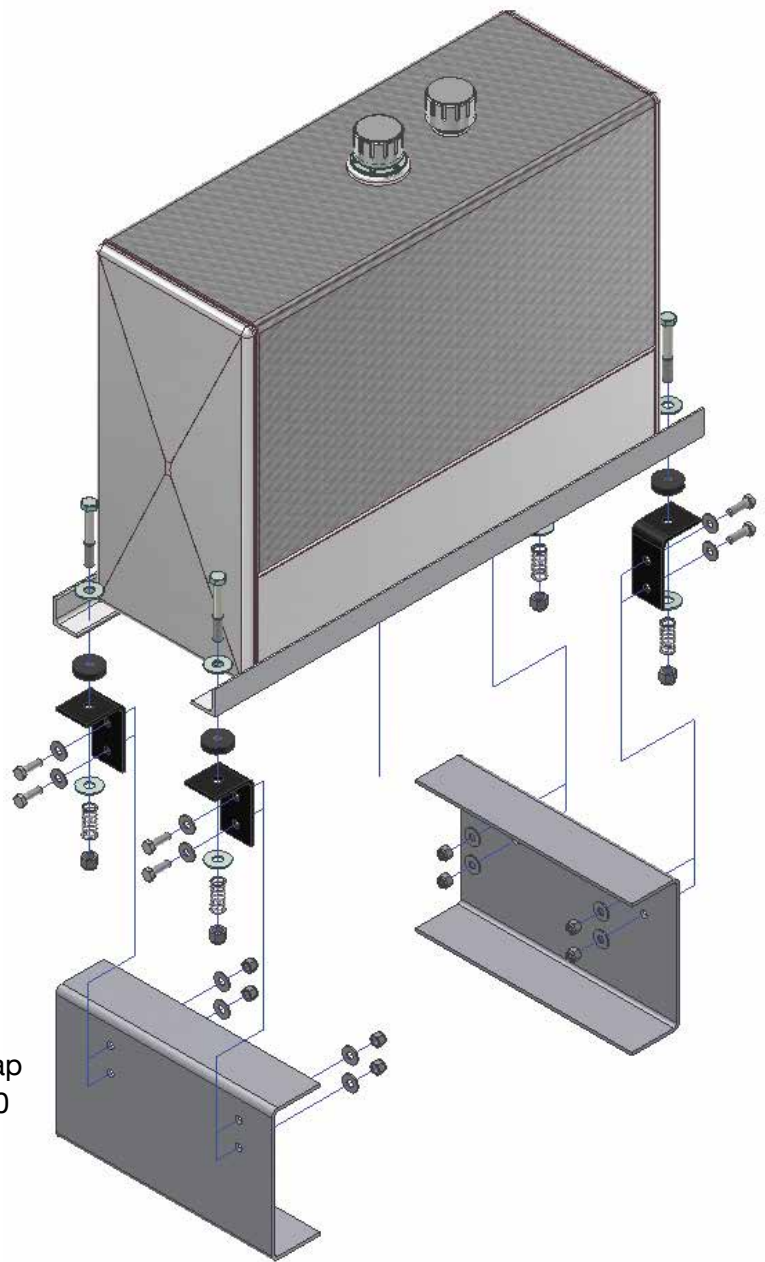

## American Wet Tank System

### Models: A3000 and A4000

#### Instructions:

1. Position tank and base assembly on frame rails of the truck chassis as desired.
2. Position chassis mounting angles so that the double pre-drilled holes are positioned against the frame rail and the single ( $1\frac{1}{16}$ " hole is positioned upward against the tank mounting angles.  
(See diagram at right.)



**Note: The top of the mounting angle should be flush with the top of the chassis rail.**

3. Using the pre-drilled mounting angles as a guide, mark both the frame rail and tank mounting angles. Chassis requires use of a  $\frac{9}{16}$ " drill bit while the mounting angles require an  $1\frac{1}{16}$ " drill bit. Drill holes and bolt the four mounting angles into place.
4. Place tank assembly across frame with mounting rails lined up directly over top holes in mounting angles. Mark and drill using a  $1\frac{1}{16}$ " drill bit
5. Place rubber mounting pads on top of the four mounting angles.  
(See diagram at right.)



**Note: The rubber pads should be above the top of the frame rails.**

6. Reposition tank over pads and angles, install bolts and springs as shown in exploded view. (See diagram at right.)



**Note: Filter/breather cap should be periodically cleaned or replaced to prevent plugging and possible system damage.**

7. **NATIONAL PIPE THREAD PORT OPENINGS:** (See diagram at right.)  
The American Wet Tank System is designed with two  $1\frac{1}{4}$ " NPT port openings in the bottom of the tank. The system allows either port to be used as a suction or return line.



The assembly may be plumbed for use as a two- or three-line system.

# American Wet Tank System

## Models: A3070 and A4070

### Mounting Kit Contents: Part Number ABK-340

Qty	Description
1	Heavy-duty mounting base panel
2	2" wide strap assemblies including four Nyloc nuts w/springs
4	13" x 2" x 1" rubber mounting pads
1	ASK-200 frame mounting kit

### Materials Required to Complete Installation:

Qty	Description
8	Cap screws 1/2", grade 5 (length determined by installer)
8	Nyloc Nuts – 1/2" - 13
16	1/2" washers

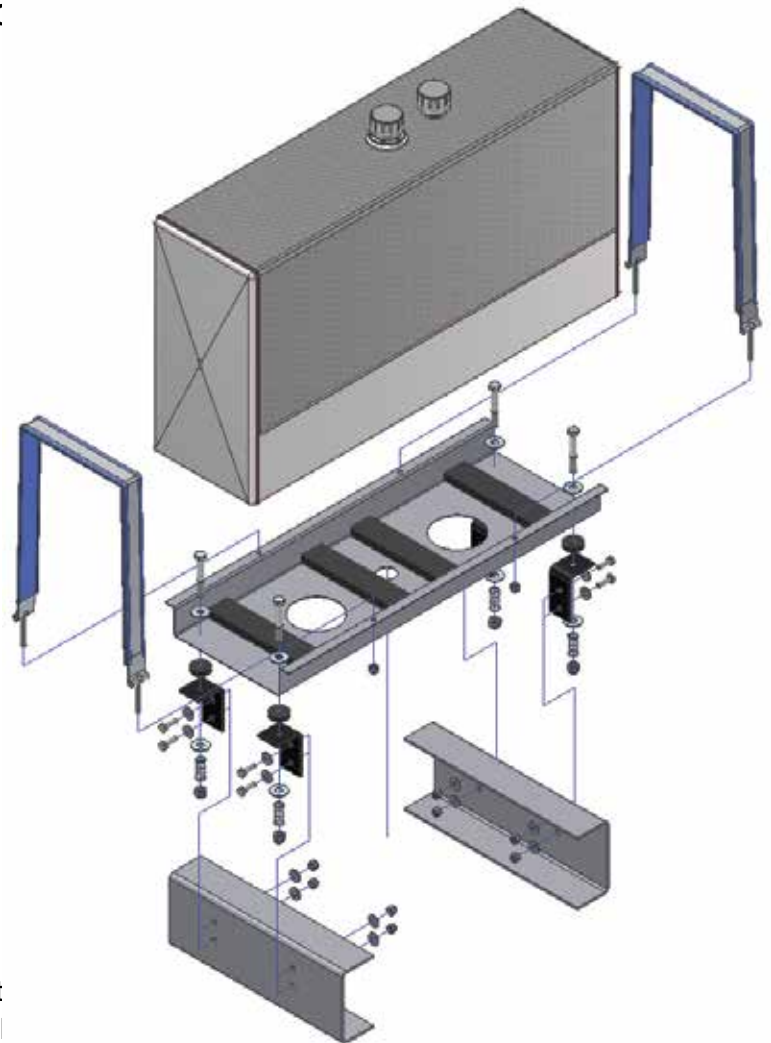

### Pre-packaged Kit Includes:

Steel or aluminum tank assembly (70 gallon) with two 1 1/2" screw-in NPT bottom ports, filler breather assembly including a 40 micron filler breather cap (chain mounted), auxiliary vent, and the ABK-340 mounting base kit.

This wet tank assembly has been designed for use as a two- or three-line system.



## American Wet Tank System

### Models: A3070 and A4070

#### Instructions:

1. Position base panel on frame rails of the truck chassis as desired.

2. Position chassis mounting angles so that the double pre-drilled holes are positioned against the frame rail and the single ( $1\frac{1}{16}$ " hole is positioned upward against the tank mounting base panel. (See diagram at right.)

**Note: The top of the mounting angle should be flush with the top of the chassis rail.**

3. Using the pre-drilled mounting angles as a guide, mark both the frame rail and tank mounting base panel. Chassis requires use of a  $\frac{9}{16}$ " drill bit while the mounting angles require an  $1\frac{1}{16}$ " drill bit. Drill holes and bolt the four mounting angles into place. (See diagram at right.)

4. Next, place base panel over angles and install bolts and springs as shown in the exploded view. (See diagram at right.)

**Note: The rubber pads should be above the top of the frame rails.**

5. Place the (4) 13" x 2" x 1" rubber mounting pads on the base panel as shown in exploded view.

Center tank on base panel, install strap assemblies. (See diagram at right.)

Rubber will conform to tank bottom as straps are tightened.

**Note: Filter/breather cap should be periodically cleaned or replaced to prevent plugging and possible system damage.**

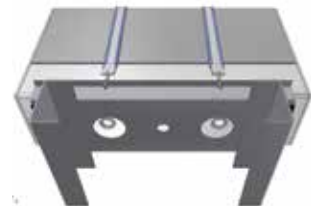

# American Wet Tank System

## Models: A30100-ST and A40100-ST

### Mounting Kit Contents: Part Number ASK-210

Qty	Description
4	Pre-drilled and powder-coated chassis mounting angles
4	Pre-drilled rubber mounting pads
4	Two inch (2") medium duty die compression springs
4	Cap screws - 5/8" - 11 x 4 1/2", grade 5
4	Nyloc nuts - 5/8" - 11
8	Plated flat washers - 5/8"
4	ASK-200G welded gusseted angles

\*ASK-200G is not included with ASK-210. Must be ordered separately.

### Materials Required to Complete Installation:

Qty	Description
8	Cap screws 1/2", grade 5 (length determined by installer)
8	Nyloc Nuts - 1/2" - 13
16	1/2" washers

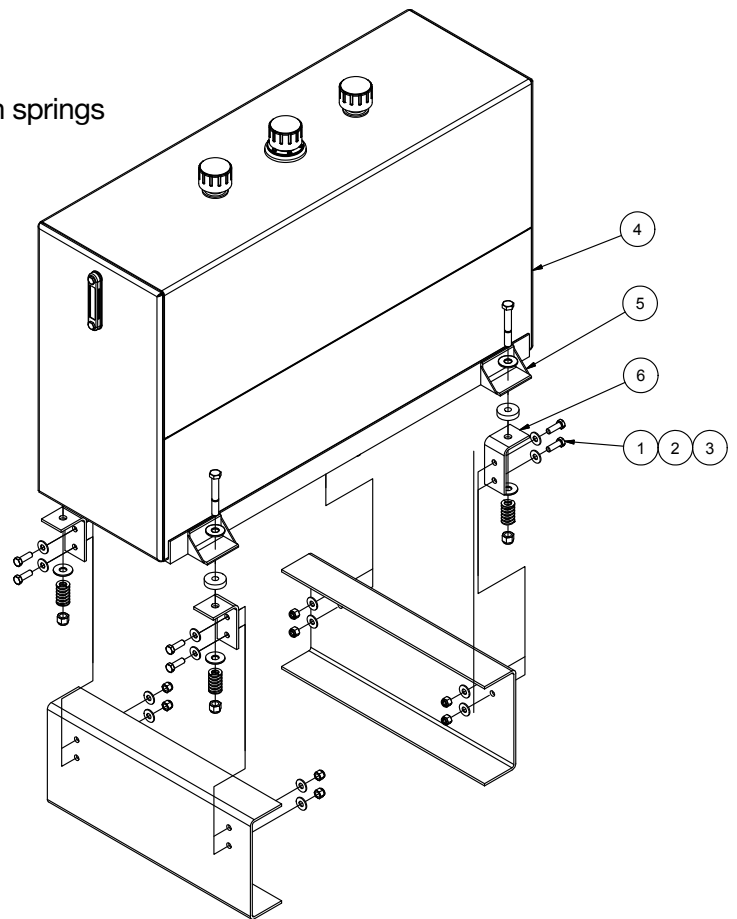

### Pre-packaged Kit Includes:

Steel or aluminum tank assembly with three, 2" heavy duty screw-in NPT bottom ports; filler/breather assembly including a 40 micron filter/breather cap (chain mounted); two, 1" auxiliary vents; and the ASK-210 mounting kit.

This wet tank assembly has been designed for a dump trailer application using either a two- or three-line system.



## American Wet Tank System Models: A30100-ST and A40100-ST

### Instructions:

1. Position tank assembly on frame rails of the truck chassis as desired.
2. Position chassis mounting angles so that the double pre-drilled holes are positioned against the frame rail and the single ( $1\frac{1}{16}$ " hole is positioned upward. Align ASK-210 angles  $\frac{1}{4}$ " from the outside edge of the extruded tank angle. (See diagram at right.)

**Note: The top of the mounting angle should be flush with the top of the chassis rail.**



3. Position the ASK-200G gusseted mounting angle over pre-drilled mounting angle. This is to be field welded to the extruded tank angle, where gusset and tank angle are flush on bottom. After positioning, mark tank and weld angles together.

**Note: The A40100-ST (aluminum version) has the gusseted angles pre-welded to the tank assembly.**

4. Using the pre-drilled mounting angles as a guide, mark both the frame rail and tank mounting angles. Chassis requires use of a  $\frac{9}{16}$ " drill bit while the mounting angles require an  $1\frac{1}{16}$ " drill bit. Drill holes and bolt the four mounting angles into place.
5. Place tank assembly across frame with gusseted angles (ASK-200G) lined up directly over top holes in mounting angles. Mark and drill using an  $1\frac{1}{16}$ " drill bit.
6. Place rubber mounting pads on top of the four mounting angles. (See diagram at right.)

**Note: The rubber pads should be above the top of the frame rails.**



7. Reposition tank over pads and angles, install bolts and springs as shown in exploded view. (See diagram at right.)
8. National Pip Thread port openings: (see diagram at right). The American Wet Tank System is designed with three, 2: NPT port openings in the bottom of the tank. The system allows either port to be used as a suction or return line.

The assembly may be plumbed for use as a two- or three-line system.

# American Wet Tank System

## Models: AR2235, AR2250, AR2275, AR8535, AR8550 and AR8575

### AR2275 and AR8575

75 Gallon Units

Requires Three Bracket Assemblies

Use Kit Number:

RMK-822-S/3 (22") or RMK-824-S/3 (24")

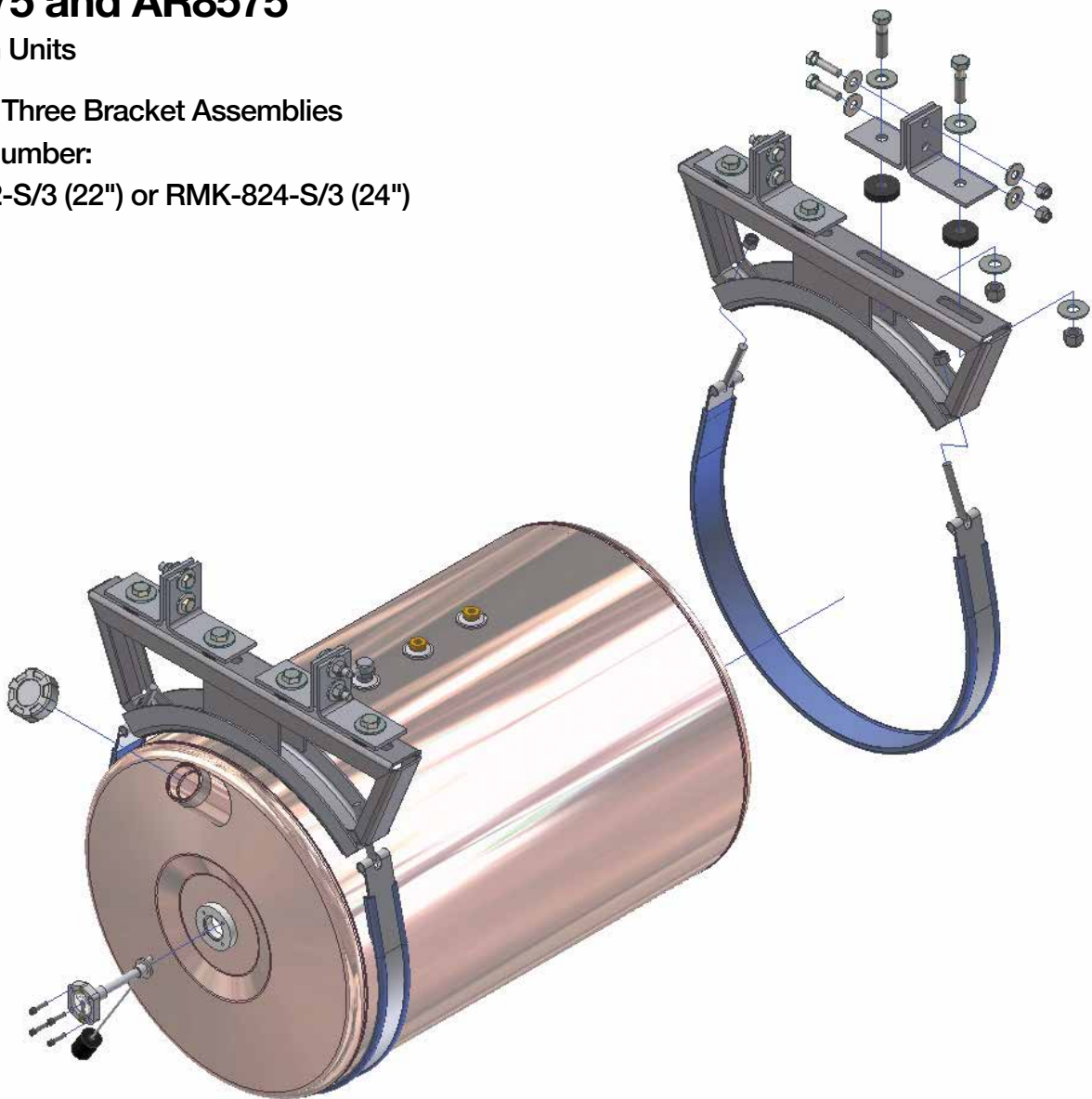

## American Wet Tank System

### Models: AR2235, AR2250, AR2275, AR8535, AR8550 and AR8575

**Mounting Kit Contents: Part Number RMK-822-S (22") or RMK-824-S (24")**

**Qty Description**

- 2 Heavy-duty Cradle Brackets – powder-coated, radius is rubber lined (affixed)
- 2 2" wide strap assemblies including (4) Nyloc nuts
- 2 ASK-200R Frame Mounting Kit

**Pre-packaged Kit Includes:**

Aluminum tank assembly (35 gallon through 75 gallon) with 2" NPT fill neck and non-vented cap; float gauge assembly (installed); three, ½" NPT top ports to accept the anti-spill vent; two, ½" x ¼" NPT pick up an return line tubes (installed); one, brass drain/check plug assembly; two, pre-punched and powder-coated, heavy-duty brackets; two, rubber-shielded stainless steel straps with Nyloc nuts; and the under body mounting hardware kit.

**Instructions:**

1. Position mounting angles so that the double pre-drilled holes are positioned against the frame rail and the single hole is facing down.

**Note: The mounting angle should be flush with the frame rail.**

2. Mark holes on frame rail and drill using a  $\frac{9}{16}$ " drill bit.
3. Reposition angles and mount using supplied ½" bolt assemblies.
4. Position cradle bracket under mounting angles and attach using supplied ⅝" bolt assemblies, using the rubber space between cradle bracket and angles.
5. Place tank against brackets and firmly tighten nuts to straps (not more than 25 ft.lbs. of torque).

**Note: Filter/breather cap should be periodically cleaned or replaced to prevent plugging and possible system damage.**



# Index

01A3AGM	Electric Digital Fuel Meter.....	58	A3535-2	Steel Saddlemount – 35 Gallon .....	16
57XL-10-3HN	Fill Cap Assembly w/3" Riser Cup .....	45	A3535-2ST	Steel Saddlemount – 35 Gallon .....	16
57XL-10-6DP	Fill Cap Assembly w/6" Dipstick.....	45	A3535-DS90-STRF	Steel Return Filter, Rear Ported Tank.....	35
57XL-40-5P	Fill Assembly w/Pressure Cap.....	45	A3575	Steel Saddlemount – 75 Gallon .....	17
906001-4	NPT Vented Cap, 2" .....	59	A3575-ST	Steel Saddlemount – 75 Gallon .....	17
A320SL	Slim Line Space Saving – 20 Gallon.....	37	A3575-2	Steel Saddlemount – 75 Gallon .....	17
A325SL	Slim Line Space Saving – 25 Gallon.....	37	A3575-2ST	Steel Saddlemount – 75 Gallon .....	17
A330SL	Slim Line/ Space Saving – 30 Gallon.....	38	A3575-2S90-ST	Steel Rear Port Hydraulic Tank .....	34
A2000	Polyethylene Upright – 50 Gallon.....	6	A4000	Aluminum Upright – 50 Gallon .....	11
A3000	Steel Upright – 50 Gallon .....	7	A4000-ST	Aluminum Upright – 50 Gallon .....	11
A3000-ST	Steel Upright – 50 Gallon .....	7	A4000-15	Aluminum Upright – 50 Gallon .....	11
A3000-15	Steel Upright – 50 Gallon .....	7	A4000-15ST	Aluminum Upright – 50 Gallon .....	11
A3000-15ST	Steel Upright – 50 Gallon .....	7	A4000-2	Aluminum Upright – 50 Gallon .....	11
A3000-2	Steel Upright – 50 Gallon .....	7	A4000-2ST	Aluminum Upright – 50 Gallon .....	11
A3000-2ST	Steel Upright – 50 Gallon .....	7	A4000-2STRF	Aluminum Return Filter, Upright Tank .....	31
A3000-2STRF	Steel Return Filter, Upright Tank.....	31	A4035-ST	Aluminum Upright – 35 Gallon .....	12
A30100-ST	Steel Upright – 100 Gallon .....	10	A4035-2ST	Aluminum Upright – 35 Gallon .....	12
A3035-2ST	Steel Upright – 35 Gallon .....	8	A4035-2STRF	Aluminum Return Filter, Upright Tank .....	31
A3035-2STRF	Steel Return Filter, Upright Tank.....	31	A4070	Aluminum Upright – 70 Gallon .....	13
A3070	Steel Upright – 70 Gallon .....	9	A4070-ST	Aluminum Upright – 70 Gallon .....	13
A3070-ST	Steel Upright – 70 Gallon .....	9	A4070-2	Aluminum Upright – 70 Gallon .....	13
A3070-2	Steel Upright – 70 Gallon .....	9	A4070-2ST	Aluminum Upright – 70 Gallon .....	13
A3070-2ST	Steel Upright – 70 Gallon .....	9	A4070-2STRF	Aluminum Return Filter, Upright Tank .....	31
A3070-2STRF	Steel Return Filter, Upright Tank.....	31	A4150	Aluminum Sidemount – 15 Gallon .....	30
A3100	Steel Side mount – 10 Gallon.....	25	A4500	Aluminum Saddlemount – 50 Gallon .....	19
A3107	Steel Sidemount – 7 Gallon.....	24	A4500-ST	Aluminum Saddlemount – 50 Gallon .....	19
A3150	Steel Sidemount – 15 Gallon.....	26	A4500-15	Aluminum Saddlemount – 50 Gallon .....	19
A3150-RF	Return Filter, Side Mounted Tank.....	36	A4500-15ST	Aluminum Saddlemount – 50 Gallon .....	19
A3250	Steel Sidemount – 25 Gallon.....	27	A4500-2	Aluminum Saddlemount – 50 Gallon .....	19
A3250-RF	Return Filter, Side Mounted Tank.....	36	A4500-2ST	Aluminum Saddlemount – 50 Gallon .....	19
A3300	Steel Sidemount – 30 Gallon.....	28	A4500-2S90-ST	Aluminum Rear Port Saddlemount – 50 Gal ..	33
A3300-RF	Return Filte, Side Mounted Tank.....	36	A4500-2S90-STRF	Aluminum Return Filter, Rear Ported Tank...	35
A3400	Steel Sidemount – 40 Gallon.....	29	A45100-ST	Aluminum Saddlemount – 100 Gallon .....	23
A3400-RF	Return Filter, Side Mounted Tank.....	36	A4525	Aluminum Saddlemount – 25 Gallon .....	20
A3500	Steel Saddlemount – 50 Gallon .....	14	A4525-ST	Aluminum Saddlemount – 25 Gallon .....	20
A3500-ST	Steel Saddlemount – 50 Gallon .....	14	A4525-2	Aluminum Saddlemount – 25 Gallon .....	20
A3500-15	Steel Saddlemount – 50 Gallon .....	14	A4525-2ST	Aluminum Saddlemount – 25 Gallon .....	20
A3500-15ST	Steel Saddlemount – 50 Gallon .....	14	A4525-DS90-STRF	Aluminum Return Filter, Rear Ported Tank...	35
A3500-2	Steel Saddlemount – 50 Gallon .....	14	A4535	Aluminum Saddlemount – 35 Gallon .....	21
A3500-2ST	Steel Saddlemount – 50 Gallon .....	14	A4535-ST	Aluminum Saddlemount – 35 Gallon .....	21
A3500-2S90-ST	Steel Rear Port Saddlemount – 50 Gallon...	33	A4535-2	Aluminum Saddlemount – 35 Gallon .....	21
A3500-2S90-STRF	Steel Return Filter Style Rear Ported Tank..	35	A4535-2ST	Aluminum Saddlemount – 35 Gallon .....	21
A35100-ST	Steel Saddlemount – 100 Gallon .....	18	A4535-DS90-ST	Aluminum Saddlemount Tank – 35 Gallon ..	33
A3525	Steel Saddlemount – 25 Gallon .....	15	A4535-DS90-STRF	Aluminum Return Filter, Rear Ported .....	35
A3525-ST	Steel Saddlemount – 25 Gallon .....	15	A4575	Aluminum Saddlemount – 75 Gallon .....	22
A3525-2	Steel Saddlemount – 25 Gallon .....	15	A4575-ST	Aluminum Saddlemount – 75 Gallon .....	22
A3525-2ST	Steel Saddlemount – 25 Gallon .....	15	A4575-2	Aluminum Saddlemount – 75 Gallon .....	22
A3525-2S90-STRF	Steel Return Filter, Rear Ported Tank.....	35	A4575-2ST	Aluminum Saddlemount – 75 Gallon .....	22
A3535	Steel Saddlemount – 35 Gallon .....	16	A4575-2S90-ST	Aluminum Rear Port Tank.....	34
A3535-ST	Steel Saddlemount – 35 Gallon .....	16	ABA-12	Breather Vent – ¾" NPT .....	46

ABA-16	Breather Vent – 1" NPT.....	46	AR8550	Aluminum Reefer Tank – 50 Gallon.....	61
ABA-138	Breather Vent – 3/8" NPT .....	46	AR8575	Aluminum Reefer Tank – 100 Gallon.....	61
ABC-315	Filler Breather Cap Only .....	46	AR22100	Aluminum Reefer Tank, 22".....	60
ABK-340-C	Carbon Mounting Kit – 70 Gallon.....	41	AR85100	Aluminum Reefer Tank – 100 Gallon.....	61
ABK-340-S	Stainless Mounting Kit – 70 Gallon .....	42	ARB-2125	Port Reducer Bushing .....	49
ADA-250	Diffuser Assembly.....	47	ARM-1010	Rapid Mount Assembly .....	53
AFA-038	Aluminum Weld Flange, 3/8".....	49	ASA-355-C	Carbon Steel Strap Assembly.....	43
AFA-050	Aluminum Weld Flange, 1/2".....	49	ASA-355-S	Stainless Steel Strap Assembly .....	43
AFA-075	Aluminum Weld Flange, 3/4".....	49	ASA-5852S	Stainless Steel Strap Complete, 22" .....	65
AFA-100	Aluminum Weld Flange, 1".....	49	ASA-6357S	Stainless Steel Strap Complete, 24" .....	65
AFA-125	Aluminum Weld Flange, 1 1/4".....	49	ASG-105	Sight/Temperature Gauge, 5" .....	47
AFA-150	Aluminum Weld Flange, 1 1/2".....	49	ASG-110	Sight/Temperature Gauge, 10" .....	47
AFA-200	Aluminum Weld Flange, 2".....	49	ASK-200	Chassis Mounting Kit .....	44
AFA-401	Aluminum Fill Adapter .....	49	ASK-200G	Gusseted Mounting Kit , 2.5" x 2.5" x 4".....	44
AFC-330	Fill Cap Assembly w/out cap .....	45	ASK-205-R	Frame Mounting Hardware .....	65
AFC-350	Fill Cap Assembly .....	45	ASK-210	Heavy-duty Chassis Mounting Kit .....	44
AFS-050	Steel Weld Flange, 1/2" .....	49	ASV-0500	NPT Anti-spill Vent, 1/2" .....	64
AFS-075	Steel Weld Flange, 3/4" .....	49	ATT-200	Transfer Mounting Base .....	59
AFS-100	Steel Weld Flange, 1" .....	49	ATT4070	Aluminum Upright – 70 Gallon .....	54
AFS-125	Steel Weld Flange, 1 1/4" .....	49	ATT4072	Aluminum Upright – 72 Gallon .....	55
AFS-150	Steel Weld Flange, 1 1/2" .....	49	ATT4075	Aluminum “ L ” Style – 75 Gallon.....	56
AFS-200	Steel Weld Flange, 2" .....	49	BCV-0500	Bottom Check Valve.....	65
AFS-301	Steel Fill Adapter.....	49	FCS-537W	Filler Cap Assembly Weather Proof .....	45
AHS-125	Hydraulic Hose Support Kit.....	52	FCS-557	Non-vented Cap Assembly.....	45
AHS-150	Hydraulic Hose Support Kit.....	52	FGA-2200	Fuel Float Gauge .....	64
AHS-200	Hydraulic Hose Support Kit.....	52	FNC-2000	Female Non-vented Cap, 2" .....	64
AMB-312	Mounting Base Panel .....	43	FNC-2000-LC	Female Non-vented Locking Cap, 2" .....	65
AMB-405HD	Mounting Base Panel – Heavy Duty .....	43	HP-100	Petroleum Hand Pump.....	57
AMK-624-C/3	Carbon Mounting Kit – 75 Gallon.....	40	LC57XL-40N	Lockable Fill Cap Assembly Vented .....	45
AMK-624-C	Carbon Steel Mounting Kit Complete.....	39	LIT-750-10P	In Tank Filter.....	48
AMK-624	“J” Bracket Only .....	43	LIT-1250-10P	In Tank Filter.....	48
AMK-624-S/3	Stainless Mounting Kit – 75 Gallon .....	40	LPBV-20	1/4" Low Pressure Ball Valve.....	53
AMK-624-S	Hydraulic Stainless Mounting Kit.....	39	LTM-25	NPT Suction Strainer.....	48
AMP-205	Rubber Inserts – Heavy-duty Mounting Base Panel.....	44	LTM-50	NPT Suction Strainer.....	48
AMP-305	“J” Bracket Rubber.....	44	LTM-100	Suction Strainer 3" to 4".....	48
AMP-400	Channel Rubber.....	43	M-150	Standard Volt Electric Pump .....	57
AMP-40053	Channel Rubber (for strap), 53" .....	44	PRT-2200	Pick-up/Return Tube, 22".....	64
APC-160	Inspection Port Cover, 6" .....	47	PRT-2400	Pick-up/Return Tube, 24".....	64
APC-160-S	Inspection Stainless Port Cover, 6" .....	47	RMK-822-S/3	Refer Heavy-duty Mounting Kit, 22" .....	63
APP-0750-M	Magnetic Port Plug, 3/4" NPT.....	49	RMK-822-S	Refer Heavy-duty Mounting Kit, 22" .....	62
APP-1000	Steel Port Plug, 1" NPT.....	49	RMK-824-S/3	Refer Heavy-duty Mounting Kit, 24" .....	63
APP-1250	Steel Port Plug, 1 1/4" NPT.....	49	RMK-824	Heavy-duty Cradle Brackets.....	65
APP-1500	Steel Port Plug, 1 1/2" NPT.....	49	RMK-824-S	Refer Heavy-duty Mounting Kit, 24" .....	62
APP-2000	Steel Port Plug, 2" NPT .....	49	WL-HK-9-8-3L	Wet Line Hose Kits/3-Line System .....	50
AQD-1010	Quick Disconnect – Complete .....	53	WL-HK-12-6-2L	Wet Line Hose Kits/2-Line System .....	51
AQF-1010	Female Coupler End, 1" .....	53	WL-HK-12-12-3L	Wet Line Hose Kits/3-Line System .....	50
AQM-1010	Male Coupler End, 1" .....	53	WL-HK-14-8-2L	Wet Line Hose Kits/2-Line System .....	51
AR2235	Aluminum Reefer Tank – 35 Gallon.....	60	WL-HK-16-8-2L	Wet Line Hose Kits/2-Line System .....	51
AR2250	Aluminum Reefer Tank – 50 Gallon.....	60	WL-HK-16-24-3L	Wet Line Hose Kits/3-Line System .....	50
AR2275	Aluminum Reefer Tank – 75 Gallon.....	60	WL-HK-20-12-2L	Wet Line Hose Kits/2-Line System .....	51
AR8535	Aluminum Reefer Tank – 35 Gallon.....	61	WL-HK-20-24-3L	Wet Line Hose Kits/3-Line System .....	50

AMERICAN...

YOUR "JUST-IN-TIME" SUPPLIER

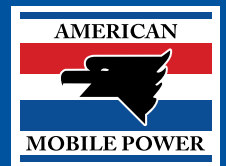

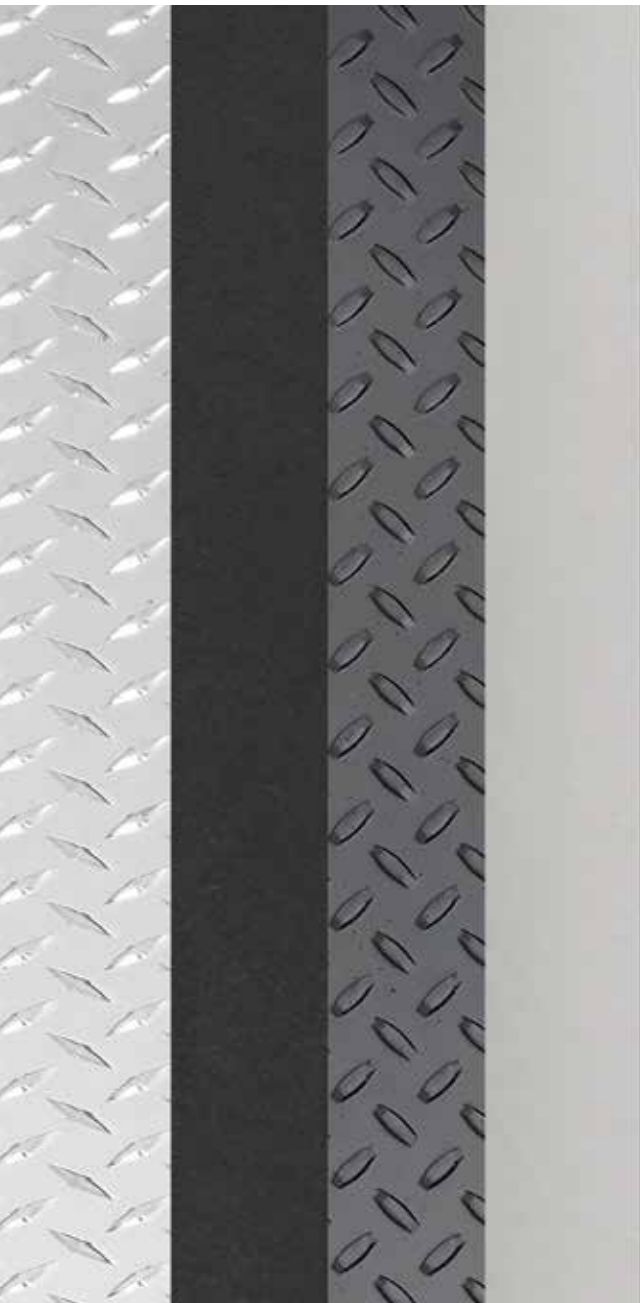

AMERICAN ...

YOUR "JUST-IN-TIME" SUPPLIER

1-800-634-8265

